

United States
Environmental Protection
Agency

Office of Water Program
Operations
Washington DC 20460

Office of Research and
Development
Municipal Environmental Research
Laboratory
Cincinnati OH 45268

Technology Transfer



Design Manual

Onsite Wastewater Treatment and Disposal Systems

EPA 625/1-80-012

DESIGN MANUAL

ONSITE WASTEWATER TREATMENT
AND DISPOSAL SYSTEMS

U.S. ENVIRONMENTAL PROTECTION AGENCY

Office of Water Program Operations

Office of Research and Development
Municipal Environmental Research Laboratory

October 1980

NOTICE

The mention of trade names or commercial products in this publication is for illustration purposes and does not constitute endorsement or recommendation for use by the U. S. Environmental Protection Agency.

FOREWORD

Rural and suburban communities are confronted with problems that are unique to their size and population density, and are often unable to superimpose solutions typically applicable to larger urban areas. A good example of such problems is the provision of wastewater services.

In the past, priorities for water pollution control focused on the cities, since waste generation from these areas was most evident. In such high-density development, the traditional sanitary engineering approach was to construct a network of sewers to convey wastewater to a central location for treatment and disposal to surface waters. Since a large number of users existed per unit length of sewer line, the costs of construction and operation could be divided among many people, thus keeping the financial burden on each user relatively low.

Within the past several decades, migration of the population from cities to suburban and rural areas has been significant. With this shift came the problems of providing utility services to the residents. Unfortunately, in many cases, solutions to wastewater problems in urban areas have been applied to rural communities. With the advent of federal programs that provide grants for construction of wastewater facilities, sewers and centralized treatment plants were constructed in these low-density rural settings. In many cases the cost of operating and maintaining such facilities impose severe economic burdens on the communities.

Although wastewater treatment and disposal systems serving single homes have been used for many years, they have often been considered an inadequate or temporary solution until sewers could be constructed. However, research has demonstrated that such systems, if constructed and maintained properly, can provide a reliable and efficient means of wastewater treatment and disposal at relatively low cost.

This document provides technical information on onsite wastewater treatment and disposal systems. It does not contain standards for those systems, nor does it contain rules or regulations pertaining to onsite systems.

The intended audience for this manual includes those involved in the design, construction, operation, maintenance, and regulation of onsite wastewater systems.

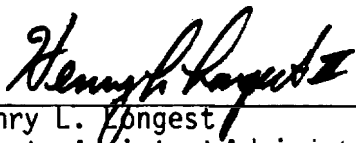

Henry L. Longest
Deputy Assistant Administrator
for Water Program Operations

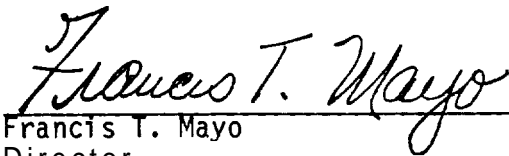

Francis T. Mayo
Director
Municipal Environmental
Research Laboratory

ACKNOWLEDGMENTS

There were three groups of participants involved in the preparation of this manual : (1) the contractor-authors, (2) the contract supervisors, and (3) the technical reviewers. The manual was written by personnel from SCS Engineers and Rural Systems Engineering (RSE). Contract supervision was provided by U.S. Environmental Protection Agency (EPA) personnel from the Municipal Construction Division in Washington, D.C. , and from the Municipal Environmental Research Laboratory in Cincinnati, Ohio. The technical reviewers were experts in certain areas of onsite waste treatment and disposal , and included professors, health officials, consultants, and government officials. Each provided technical review of a section or sections of the report. The membership of each group is listed below.

CONTRACTOR-AUTHORS:

Direction: Curtis J. Schmidt, SCS
William C. Boyle, RSE

Senior Authors: Ernest V. Clements, Project Manager, SCS
Richard J. Otis, RSE

Contributing Authors: David H. Bauer, SCS
Robert L. Siegrist, E. Jerry Tyler,
David E. Stewart, James C. Converse, RSE

CONTRACT SUPERVISORS:

Project Officers: Robert M. Southworth, OWPO, EPA, Washington, D.C.
Robert P. G. Bowker, MERL, EPA, Cincinnati, Ohio

Reviewers: James Kreissl, MERL , EPA, Cincinnati , Ohio
Denis Lussier, CERL, EPA, Cincinnati, Ohio
Sherwood Reed, CRREL, COE, Hanover, N.H.

TECHNICAL REVIEWERS:

1. Michael Hansel - Minnesota Pollution Control Agency
2. Roger Machmeier - University of Minnesota
3. Jack Abney - Parrott, Ely & Hurt, Inc., Lexington, Kentucky
4. William Mellen - Lake County Health Department, Illinois
5. Rein Laak - University of Connecticut
6. Gary Plews - Washington Department of Social & Health Services
7. B. L. Carlile - North Carolina State University
8. John Clayton - Fairfax County Health Department, Virginia
9. William Sharpe - Pennsylvania State University
10. Elmer Jones - U.S. Department of Agriculture
11. Edwin Bennett - University of Colorado
12. Harry Pence - Virginia Polytechnic Institute
13. Briar Cook - U.S. Department of Agriculture, Forest Service
14. Marek Brandes - Ontario Ministry of the Environment (Retired)
15. Michael Hines - Illinois State Department of Public Health
16. John Fancy - John Fancy, Inc. , Waldoboro, Maine

CONTENTS

<u>Chapter</u>		<u>Page</u>
	FORWARD	iii
	ACKNOWLEDGEMENTS	v
	CONTENTS	vii
	LIST OF FIGURES	ix
	LIST OF TABLES	xv
1	INTRODUCTION	
	1.1 Background	1
	1.2 Purpose	2
	1.3 Scope	3
2	STRATEGY FOR ONSITE SYSTEM DESIGN	
	2.1 Introduction	4
	2.2 Onsite System Design Strategy	4
3	SITE EVALUATION PROCEDURES	
	3.1 Introduction	13
	3.2 Disposal Alternatives	13
	3.3 Site Evaluation Strategy	17
	3.4 References	48
4	WASTEWATER CHARACTERISTICS	
	4.1 Introduction	50
	4.2 Residential Wastewater Characteristics	50
	4.3 Nonresidential Wastewater Characteristics	57
	4.4 Predicting Wastewater Characteristics	65
	4.5 References	68
5	WASTEWATER MODIFICATION	
	5.1 Introduction	70
	5.2 Water Conservation and Wastewater Flow Reduction	71
	5.3 Pollutant Mass Reduction	84
	5.4 Onsite Containment - Holding Tanks	88
	5.5 Reliability	88
	5.6 Impacts on Onsite Treatment and Disposal Practices	92
	5.7 References	95

CONTENTS (continued)

<u>Chapter</u>		<u>Page</u>
6	ONSITE TREATMENT METHODS	
	6.1 Introduction	97
	6.2 Septic Tanks	98
	6.3 Intermittent Sand Filters	113
	6.4 Aerobic Treatment Units	140
	6.5 Disinfection	161
	6.6 Nutrient Removal	184
	6.7 Waste Segregation and Recycle Systems	197
	6.8 References	199
7	DISPOSAL METHODS	
	7.1 Introduction	206
	7.2 Subsurface Soil Absorption	207
	7.3 Evaporation Systems	300
	7.4 Outfall to Surface Waters	316
	7.5 References	316
8	APPURTENANCES	
	8.1 Introduction	321
	8.2 Grease Traps	321
	8.3 Dosing Chambers	327
	8.4 Flow Diversion Methods for Alternating Beds	335
	8.5 References	337
9	RESIDUALS DISPOSAL	
	9.1 Introduction	338
	9.2 Residuals Characteristics	338
	9.3 Residuals Handling Option	343
	9.4 Ultimate Disposal of Septage	343
	9.5 References	351
10	MANAGEMENT OF ONSITE SYSTEMS	
	10.1 Introduction	353
	10.2 Theory of Management	354
	10.3 Types of Management Entities	355
	10.4 Management Program Functions	358
	10.5 References	366
	APPENDIX - Soil Properties and Soil-Water Relationships	367
	GLOSSARY	382

FIGURES

<u>Number</u>		<u>Page</u>
2-1	Onsite Wastewater Management Options	5
2-2	Onsite System Design Strategy	7
3-1	Potential Evaporation Versus Mean Annual Precipitation	16
3-2	Example of a Portion of a Soil Map as Published in a Detailed Soil Survey (Actual Size)	20
3-3	Translation of Typical Soil Mapping Unit Symbol	20
3-4	Plot Plan Showing Soil Series Boundaries from Soil Survey Report	23
3-5	Plot Plan Showing Surface Features	25
3-6	Landscape Positions	27
3-7	Methods of Expressing Land Slopes	27
3-8	Preparation of Soil Sample for Field Determination of Soil Texture	30
3-9	Soil Texture Determination by Hand: Physical Appearance of Various Soil Textures	32
3-10	Comparison of Ribbons and Casts of Sandy Loam and Clay (Ribbons Above, Casts Below)	33
3-11	Example Procedure for Collecting Soil Pit Observation Information	34
3-12	Types of Soil Structure	36
3-13	Typical Observation Well for Determining Soil Saturation	38
3-14	Construction of a Percometer	42
3-15	Percolation Test Data Form	43
3-16	Compilation of Soils and Site Information (Information Includes Topographic, Soil Survey, Onsite Slope and Soil Pit Observations)	45

FIGURES (continued)

<u>Number</u>		<u>Page</u>
4-1	Frequency Distribution for Average Daily Residential Water Use/Waste Flows	53
4-2	Peak Discharge Versus Fixture Units Present	64
4-3	Strategy for Predicting Wastewater Characteristics	67
5-1	Example Strategies for Management of Segregated Human Wastes	89
5-2	Example Strategies for Management of Residential Graywater	89
5-3	Flow Reduction Effects on Pollutant Concentrations	93
6-1	Typical Septic Tank Outlet Structures to Minimize Suspended Solids in Discharge	105
6-2	Septic Tank Scum and Sludge Clear Spaces	107
6-3	Typical Two-Compartment Septic Tank	108
6-4	Four Precast Reinforced Concrete Septic Tanks Combined into One Unit for Large Flow Application	114
6-5	Typical Buried Intermittent Filter Installation	129
6-6	Typical Free Access Intermittent Filter	131
6-7	Typical Recirculating Intermittent Filter System	134
6-8	Recirculation Tank	134
6-9	By-Pass Alternatives for Recirculating Filters	135
6-10	Aerobic and Anaerobic Decomposition Products	142
6-11	Examples of Extended Aeration Package Plant Configurations	144
6-12	Examples of Fixed Film Package Plant Configurations	156
6-13	Stack Feed Chlorinator	171

FIGURES (continued)

<u>Number</u>		<u>Page</u>
6-14	Iodine Saturator	172
6-15	Sample Contact Chamber	174
6-16	Typical UV Disinfection Unit	177
6-17	Typical UV Sterilizing Chamber	178
6-18	Onsite Denitrification Systems	190
7-1	Typical Trench System	209
7-2	Typical Bed System	210
7-3	Alternating Trench System with Diversion Valve	218
7-4	Provision of a Reserve Area Between Trenches of the Initial System on a Sloping Site	220
7-5	Trench System Installed to Overcome a Shallow Water Table or Restrictive Layer	222
7-6	Typical Inspection Pipe	228
7-7	Backhoe Bucket with Removable Raker Teeth	228
7-8	Methods of Soil Absorption Field Rehabilitation	232
7-9	Seepage Pit Cross Section	236
7-10	Typical Mound Systems	240
7-11	Detailed Schematic of a Mound System	241
7-12	Proper Orientation of a Mound System on a Complex Slope	246
7-13	Mound Dimensions	247
7-14	Tiered Mound System	257
7-15	Curtain Drain to Intercept Laterally Moving Perched Water Table Caused by a Shallow, Impermeable Layer	261

FIGURES (continued)

<u>Number</u>		<u>Page</u>
7-16	Vertical Drain to Intercept Laterally Moving Perched Water Table Caused by a Shallow, Thin, Impermeable Layer	261
7-17	Underdrains Used to Lower Water Table	262
7-18	Typical Electro-Osmosis System	270
7-19	Single Line Distribution Network	273
7-20	Drop Box Distribution Network	274
7-21	Closed Loop Distribution Network	276
7-22	Distribution Box Network	277
7-23	Relief Line Distribution Network	279
7-24	Central Manifold Distribution Network	280
7-25	End Manifold Distribution Network	281
7-26	Lateral Detail - Tee to Tee Construction	282
7-27	Lateral Detail - Staggered Tees or Cross Construction	283
7-28	Required Lateral Pipe Diameters for Various Hole Diameters, Hole Spacings, and Lateral Lengths (for Plastic Pipe Only)	285
7-29	Recommended Manifold Diameters for Various Manifold Lengths, Number of Laterals, and Lateral Discharge Rates (for Plastic Pipe Only)	286
7-30	Nomograph for Determining the Minimum Dose Volume for a Given Lateral Diameter, Lateral Length, and Number of Laterals	287
7-31	Distribution Network for Example 7-2	289
7-32	Distribution Network for Example 7-3	294
7-33	Schematic of a Leaching Chamber	298

FIGURES (continued)

<u>Number</u>		<u>Page</u>
7-34	Use of Metal Holders for the Laying of Flexible Plastic Pipe	299
7-35	Cross Section of Typical ET Bed	302
7-36	Curve for Establishing Permanent Home Loading Rate for Boulder, Colorado Based on Winter Data, 1976-1977	307
7-37	Typical Evaporation/Filtration Lagoon for Small Installations	312
8-1	Double-Compartment Grease Trap	326
8-2	Typical Dosing Chamber with Pump	329
8-3	Level Control Switches	331
8-4	Typical Dosing Chamber with Siphon	333
8-5	Typical Diversion Valve	335
8-6	Top View of Diversion Box Utilizing a Treated Wood Gate	336
8-7	Section View of Diversion Box Utilizing Adjustable Ells	336
A-1	Names and Size Limits of Practical-Size Classes According to Six Systems	368
A-2	Textural Triangle Defining Twelve Textural Classes of the USDA (Illustrated for a Sample Containing 37% Sand, 45% Silt, and 18%Clay)	370
A-3	Schematic Diagram of a Landscape and Different Soils Possible	375
A-4	Upward Movement by Capillarity in Glass Tubes as Compared with Soils	377
A-5	Soil Moisture Retention for Four Different Soil Textures	378

FIGURES (continued)

<u>Number</u>		<u>Page</u>
A-6	Hydraulic Conductivity (K) Versus Soil Moisture Retention	379
A-7	Schematic Representation of Water Movement Through a Soil with Crusts of Different Resistances	381

TABLES

<u>Number</u>		<u>Page</u>
2-1	Selection of Disposal Methods Under Various Site Constraints	9
3-1	Suggested Site Evaluation Procedure	18
3-2	Soil Limitations Ratings Used by SCS for Septic Tank/Soil Absorption Fields	22
3-3	Soil Survey Report Information for Parcel in Figure 3-4	24
3-4	Textural Properties of Mineral Soils	31
3-5	Grades of Soil Structure	36
3-6	Description of Soil Mottles	37
3-7	Estimated Hydraulic Characteristics of Soil	39
3-8	Falling Head Percolation Test Procedure	41
4-1	Summary of Average Daily Residential Wastewater Flows	52
4-2	Residential Water Use by Activity	54
4-3	Characteristics of Typical Residential Wastewater	56
4-4	Pollutant Contributions of Major Residential Wastewater Fractions (gm/cap/day)	58
4-5	Pollutant Concentrations of Major Residential Wastewater Fractions (mg/l)	58
4-6	Typical Wastewater Flows from Commercial Sources	60
4-7	Typical Wastewater Flows from Institutional Sources	61
4-8	Typical Wastewater Flows from Recreational Sources	62
4-9	Fixture-Units per Fixture	63
5-1	Example Wastewater Flow Reduction Methods	72

TABLES (continued)

<u>Number</u>		<u>Page</u>
5-2	Wastewater Flow Reduction - Water Carriage Toilets and Systems	74
5-3	Wastewater Flow Reduction - Non-Water Carriage Toilets	77
5-4	Wastewater Flow Reduction - Bathing Devices and Systems	79
5-5	Wastewater Flow Reduction - Miscellaneous Devices and Systems	82
5-6	Wastewater Flow Reduction - Wastewater Recycle and Reuse Systems	85
5-7	Example Pollutant Mass Reduction Methods	87
5-8	Additional Considerations in the Design, Installation and Operation of Holding Tanks	90
5-9	Potential Impacts of Wastewater Modification on Onsite Disposal Practices	94
6-1	Summary of Effluent Data from Various Septic Tank Studies	100
6-2	Typical Septic Tank Liquid Volume Requirements	103
6-3	Location of Top and Bottom of Outlet Tee or Baffle	107
6-4	Performance of Buried Intermittent Filters - Septic Tank Effluent	121
6-5	Performance of Free Access Intermittent Filters	122
6-6	Performance of Recirculating Intermittent Filters	123
6-7	Design Criteria for Buried Intermittent Filters	124
6-8	Design Criteria for Free Access Intermittent Filters	126
6-9	Design Criteria for Recirculating Intermittent Filters	128
6-10	Operation and Maintenance Requirements for Buried Intermittent Filters	138

TABLES (continued)

<u>Number</u>		<u>Page</u>
6-11	Operation and Maintenance Requirements for Free Access Intermittent Filters	138
6-12	Operation and Maintenance Requirements for Recirculating Intermittent Filters	139
6-13	Summary of Effluent Data from Various Aerobic Unit Field Studies	146
6-14	Typical Operating Parameters for Onsite Extended Aeration Systems	151
6-15	Suggested Maintenance for Onsite Extended Aeration Package Plants	153
6-16	Operational Problems - Extended Aeration Package Plants	154
6-17	Typical Operating Parameters for Onsite Fixed Film Systems	158
6-18	Suggested Maintenance for Onsite Fixed Film Package Plants	160
6-19	Operational Problems - Fixed Film Package Plants	162
6-20	Selected Potential Disinfectants for Onsite Application	163
6-21	Halogen Properties	164
6-22	Chlorine Demand of Selected Domestic Wastewaters	165
6-23	Performance of Halogens and Ozone at 25°C	167
6-24	Halogen Dosage Design Guidelines	168
6-25	UV Dosage for Selected Organisms	180
6-26	Potential Onsite Nitrogen Control Options	186
6-27	Potential Onsite Phosphorus Removal Options	194
6-28	Phosphorus Adsorption Estimates for Selected Natural Materials	198

TABLES (continued)

<u>Number</u>		<u>Page</u>
7-1	Site Criteria for Trench and Bed Systems	212
7-2	Recommended Rates of Wastewater Application for Trench and Bed Bottom Areas .	214
7-3	Typical Dimensions for Trenches and Beds	221
7-4	Dosing Frequencies for Various Soil Textures	224
7-5	Methods of Wastewater Application for Various System Designs and Soil Permeabilities	225
7-6	Sidewall Areas of Circular Seepage Pits (ft ²)	237
7-7	Site Criteria for Mound Systems	242
7-8	Commonly Used Fill Materials and their Design Infiltration Rates	245
7-9	Dimensions for Mound Systems	248
7-10	Infiltration Rates for Determining Mound Basal Area	249
7-11	Drainage Methods for Various Site Characteristics	266
7-12	Distribution Networks for Various System Designs and Application Methods	271
7-13	Discharge Rates for Various Sized Holes at Various Pressures (gpm)	284
7-14	Friction Loss in Schedule 40 Plastic Pipe, C=150 (ft/100 ft)	291
7-15	Pipe Materials for Nonpressurized Distribution Networks	297
7-16	Sample Water Balance for Evaporation Lagoon Design	314
8-1	Recommended Ratings for Commercial Grease Traps	324
9-1	Residuals Generated from Onsite Wastewater Systems	339

TABLES (continued)

<u>Number</u>		<u>Page</u>
9-2	Characteristics of Domestic Septage	340
9-3	Indicator Organism and Pathogen Concentrations in Domestic Septage	342
9-4	Land Disposal Alternatives for Septage	345
9-5	Independent Septage Treatment Facilities	340
9-6	Septage Treatment at Wastewater Treatment Plants	350
10-1	Site Evaluation and System Design Functions	359
10-2	Installation Functions	362
10-3	Operation and Maintenance Functions	364
10-4	Rehabilitation Functions	365
A-1	U.S. Department of Agriculture Size Limits for Soil Separates	367
A-2	Types and Classes of Soil Structure	372

CHAPTER 1

INTRODUCTION

1.1 Background

Approximately 18 million housing units, or 25% of all housing units in the United States, dispose of their wastewater using onsite wastewater treatment and disposal systems. These systems include a variety of components and configurations, the most common being the septic tank/soil absorption system. The number of onsite systems is increasing, with about one-half million new systems being installed each year.

The first onsite treatment and disposal systems were constructed by homeowners themselves or by local entrepreneurs in accordance with design criteria furnished by federal or state health departments. Usually, a septic tank followed by a soil absorption field was installed. Trenches in the soil absorption system were dug wide enough to accommodate open-jointed drain tile laid directly on the exposed trench bottom. Some health departments suggested that deeper and wider trenches be used in "dense" soils and that the bottom of those trenches be covered with coarse aggregate before the drain tile was laid. The purposes of the aggregate were to provide a porous media through which the septic tank effluent could flow and to provide storage of the liquid until it could infiltrate into the surrounding soil.

It has been estimated that only 32% of the total land area in the United States has soils suitable for onsite systems which utilize the soil for final treatment and disposal of wastewater. In areas where there is pressure for development, onsite systems have often been installed on land that is not suitable for conventional soil absorption systems. Cases of contaminated wells attributed to inadequately treated septic tank effluent, and nutrient enrichment of lakes from near-shore development are examples of what may occur when a soil absorption system is installed in an area with unsuitable soil or geological conditions. Alarmed by the potential health hazards of improperly functioning systems, public health officials have continually sought methods to improve the design and performance of onsite systems.

Unfortunately, the great increases in population have exacerbated the problems associated with onsite systems. The luxury of vast amounts of land for homesites is gone; instead, denser housing in rural areas is more common.

In many areas, onsite systems have been plagued by poor public acceptance; feelings that those systems were second rate, temporary, or failure prone. This perspective contributed to poorly designed, poorly constructed, and inadequately maintained onsite systems.

Recently, the situation has begun to change. Federal, state, and local governments have refocused their attention on rural wastewater disposal and, more particularly, on wastewater systems affordable by the rural population. Onsite systems are now gaining desired recognition as a viable wastewater management alternative that can provide excellent, reliable service at a reasonable cost, while still preserving environmental quality. Federal and many state and local governments have initiated public education programs dealing with the technical and administrative aspects of onsite systems and other less costly wastewater handling alternatives for rural areas.

In this time of population movements to rural and semirural areas, high costs of centralized sewage collection and treatment, and new funding incentives for cost and energy saving technologies, those involved with rural wastewater management need more information on the planning, design, construction, and management of onsite systems. This process design manual provides primarily technical guidance on the design, construction, and maintenance of such systems.

1.2 Purpose

This document provides information on generic types of onsite wastewater treatment and disposal systems. It contains neither standards for those systems nor rules and regulations pertaining to onsite systems. The design information presented herein is intended as technical guidance reflective of sound, professional practice. The intended audience for the manual includes those involved in the design, construction, operation, maintenance, and regulation of onsite systems.

Technologies discussed in this manual were selected because of past operating experience and/or because of the availability of information and performance data on those processes. Because a particular wastewater handling option is not discussed in this manual does not mean that it is not acceptable. All available technologies should be considered when planning wastewater management systems for rural and suburban communities.

Groundwater and surface water pollution are major environmental considerations when onsite systems are used. All wastewater treatment and disposal systems must be designed, constructed, operated, and maintained

to prevent degradation of both groundwater and surface water quality. For onsite systems designed and constructed using Environmental Protection Agency funds, all applicable regulations must be complied with, including requirements for disposal to groundwaters (4 FR 6190, February 11, 1976).

This manual is only a guide. Before an onsite system is designed and constructed, appropriate local or state authorities should be contacted to determine the local design requirements for a particular system.

1.3 Scope

This manual includes:

1. A strategy for selecting an onsite system
2. A procedure for conducting a site evaluation
3. A summary of wastewater characteristics
4. A discussion of waste load modification
5. A presentation of generic onsite wastewater treatment methods
6. A presentation of generic onsite wastewater disposal methods
7. A discussion of appurtenances for onsite systems
8. An overview of residuals characteristics and treatment/disposal alternatives
9. A discussion of management of onsite systems

The emphasis of this manual is on systems for single dwellings and small clusters of up to 10 to 12 housing units. Additional factors must be considered for clusters of systems serving more than 10 to 12 housing units. A brief discussion of onsite systems for multi-home units and commercial/institutional establishments is also presented, when the system designs differ significantly from those for single dwellings.

CHAPTER 2

STRATEGY FOR ONSITE SYSTEM DESIGN

2.1 Introduction

A wide variety of onsite system designs exist from which to select the most appropriate for a given site. The primary criterion for selection of one design over another is protection of the public health while preventing environmental degradation. Secondary criteria are cost and ease of operating and maintaining the system. The fate of any residuals resulting from the treatment and disposal system must be considered in the selection process.

Figure 2-1 summarizes wastewater management options for onsite systems. Because of the wide variety, selection of the system that prevents public health hazards and maintains environmental quality at the least cost is a difficult task. The purpose of this chapter is to present a strategy for selecting the optimum onsite system for a particular environment. At each step, the reader is referred to the appropriate chapters in the manual for site evaluation, and subsequent system design, construction, operation and maintenance, and residuals disposal.

2.2 Onsite System Design Strategy

Traditionally, subsurface soil absorption has been used almost exclusively for onsite disposal of wastewater because of its ability to meet the public health and environmental criteria without the necessity for complex design or high cost. A properly designed, constructed, and maintained subsurface absorption system performs reliably over a long period of time with little attention. This is because of the large natural capacity of the soil to assimilate the wastewater pollutants.

Unfortunately, much of the land area in the United States does not have soils suited for conventional subsurface soil absorption fields. If soil absorption cannot be utilized, wastewater also may be safely disposed of into surface waters or evaporated into the atmosphere. However, more complex systems may be required to reliably meet the public health and environmental criteria where these disposal methods are used. Not only are complex systems often more costly to construct, but they are also more difficult and costly to maintain. Therefore, the onsite system selection strategy described here is based on the assumption that

FIGURE 2-1

ONSITE WASTEWATER MANAGEMENT OPTIONS

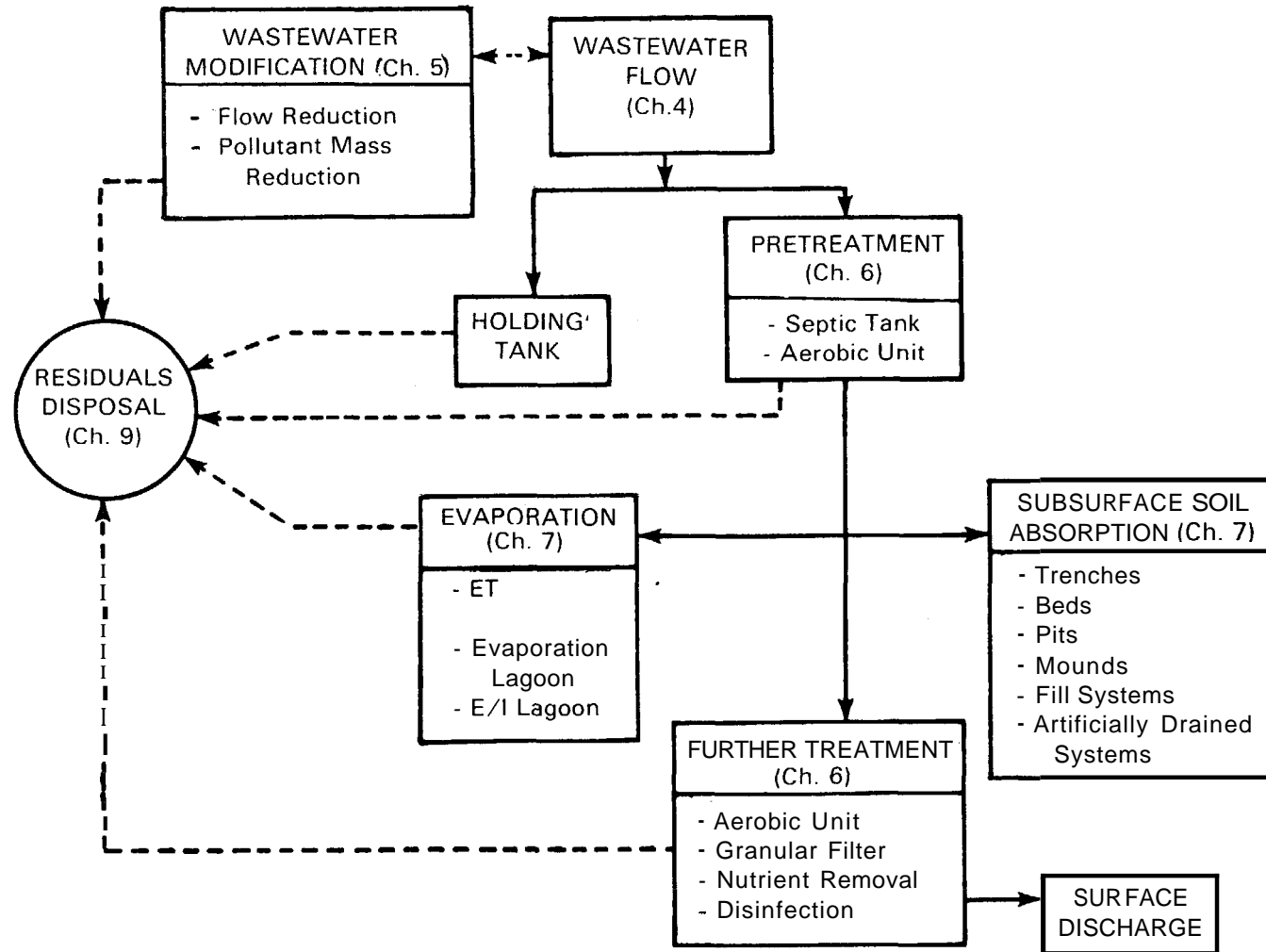

subsurface soil absorption is the preferred onsite disposal option because of its greater reliability with a minimum of attention. Where the site characteristics are unsuitable for conventional subsurface soil absorption systems, other subsurface soil absorption systems may be possible. Though these other systems may be more costly to construct than systems employing surface water discharge or evaporation, their reliable performance under a minimum of supervision may make them the preferred alternative. Figure 2-2 illustrates the onsite system design strategy discussed in this chapter.

2.2.1 Preliminary System Screening

The first step in the design of an onsite system is the selection of the most appropriate components to make up the system. Since the site characteristics constrain the method of disposal more than other components, the disposal component must be selected first. Selection of wastewater modification and treatment components follow. To select the disposal method properly, a detailed site evaluation is required. However, the site characteristics that must be evaluated may vary with the disposal method. Since it is not economical nor practical to evaluate a site for every conceivable system design, the purpose of this first step is to eliminate the disposal options with the least potential so that the detailed site evaluation can concentrate on the most promising options.

To effectively screen the disposal options, the wastewater to be treated and disposed must be characterized, and an initial site investigation made.

2.2.1.1 Wastewater Characterization

The estimated daily wastewater volume and any short- or long-term variations in flow affect the size of many of the system components. In addition, the concentrations of various constituents can affect the treatment and disposal options chosen. Characteristics are presented in Chapter 4 for wastewater from residential dwellings as well as from commercial operations.

2.2.1.2 Initial Site Evaluation

All useful information about the site should be collected. This may be accomplished by client contact, a review of available published resource information and records, and an initial site visit. Client contact and a review of published maps and reports should provide information regarding the soils, geology, topography, climate, and other physical

FIGURE 2-2

ONSITE SYSTEM DESIGN STRATEGY

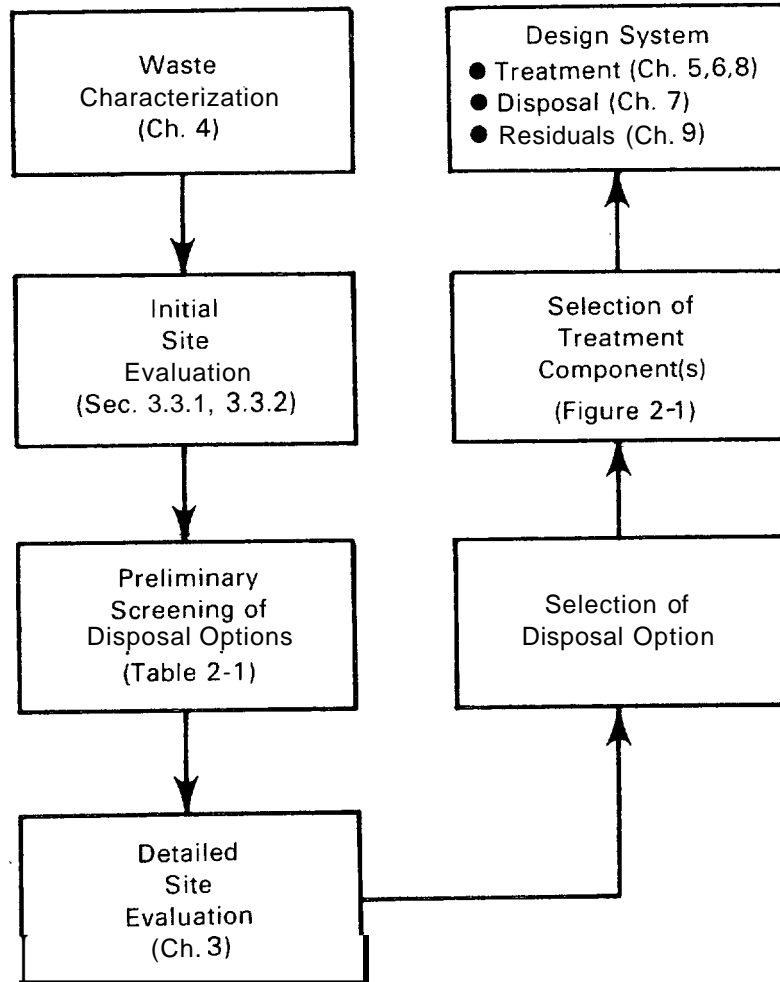

features of the site (See 3.3.1 and 3.3.2). An initial site visit should also be made, and should include a visual survey of the area and preliminary field testing, if required, with a hand auger (See 3.3.3). From this site visit, general site features such as relative soil permeability, depth and nature of bedrock, depth to water table, slope, lot size, and landscape position should be identified. Sources of information and evaluation procedures for site evaluation are detailed in Chapter 3.

2.2.1.3 Preliminary Screening of Disposal Options

From the wastewater characteristics and site information gathered in this step, a preliminary screening of the disposal options can be made using Table 2-1. This table indicates the onsite disposal options that potentially may work for the given site constraints. The potentially feasible disposal options are identified by noting which ones perform effectively under all the given site constraints. Note that with sufficient treatment and presence of receiving waters, surface water discharge is always a potential disposal option.

As an example, suppose a site for a single-family home has the following general characteristics:

1. Very rapidly permeable soil
2. Deep bedrock
3. Shallow water table
4. Five to 15 percent slope
5. Large lot
6. Low evaporation potential

From Table 2-1, the disposal options most applicable to the example site constraints are:

1. Mounds
2. Fills
3. Surface water discharge

The design sections in Chapter 7 would be consulted at this point to determine the specific characteristics to be evaluated at the site in order to select the most feasible disposal options,

TABLE 2-1

SELECTION OF DISPOSAL METHODS UNDER VARIOUS SITE CONSTRAINTS

Method	Site Constraints											
	Soil Permeability			Depth to Bedrock			Depth to Water table		Slope			Small Lot Size
	Very Rapid	Rapid-Moderate	Slow-Very Slow	Shallow and Porous	Shallow and Nonporous	Deep	Shallow	Deep	0-5%	5-15%	15%	
Trenches		X	X ²			X		X	X	X	X	X ⁴
Beds		X				X		X	X			X
Pits		X				X		X	X	X	X	X
Mounds	X	X	X	X	X	X	X	X	X	X		
Fill Systems	X	X ¹	X ¹	X	X	X	X	X	X	X	X	X ⁴
Sand-Lined Trenches or Beds	X	X	X ²			X		X	X	X ³	X ³	X ⁴
Artificially Drained Systems		X				X	X		X	X	X ³	
Evaporation Infiltration Lagoons		X	X ⁵			X		X	X			
Evaporation Lagoons (lined) ^{4,5}	X	X	X	X	X	X	X	X	X			
ET Beds or Trenches (lined) ^{4,5}	X	X	X	X	X	X	X	X	X	X ⁶		
ETA Beds or Trenches ⁴		X	X			X		X	X	X	X	X

¹ Only where surface soil can be stripped to expose sand or sandy loam material.

² Construct only during dry soil conditions. Use trench configuration only.

³ Trenches only.

⁴ Flow reduction suggested.

⁵ High Evaporation potential required.

⁶ Recommended for south-facing slopes only.

X means system can function effectively with that constraint.

2.2.2 System Selection

With the potentially feasible disposal options in mind, a detailed site evaluation is performed. The information collected is used to identify the system options that meet the public health and environmental criteria. If more than one system is feasible, final selection is based on results of a cost effective analysis. Local codes should be consulted to determine which onsite treatment and disposal methods are permitted in the area.

2.2.2.1 Detailed Site Evaluation

A careful, detailed site evaluation is needed to provide sufficient information to select the most appropriate treatment and disposal system from the potentially feasible system options. The evaluation should be performed in a systematic manner so as to insure that the information collected is useful and in sufficient detail. A site evaluation procedure is suggested in Chapter 3, including descriptions of the tests and observations to be made. This procedure is based on the assumption that subsurface soil absorption is the preferred method of disposal. If subsurface absorption cannot be used, techniques are explained for evaluating the suitability of a site for surface water discharge or evaporation.

2.2.2.2 Selection of Most Appropriate System

The disposal option selected after the detailed site evaluation dictates the quality of the wastewater required prior to disposal. If suitable soils exist onsite to employ one of the subsurface soil absorption methods of disposal, the quality of the wastewater applied need not be high due to the assimilative capacity of the soil. Where suitable soils do not exist onsite, other methods of disposal that require a higher quality of wastewater may be necessary. These wastewater quality requirements are established during the site evaluation (Chapter 3). Wastewater reduction and treatment options are selected to meet the required wastewater quality.

Altering the characteristics of the wastewater generated can have a major impact on the design of the treatment and disposal system. Alteration can be beneficial in reducing the size or complexity of the system. Chapter 5 describes a variety of wastewater reduction options.

Chapter 6 provides detailed information regarding the design, construction and operation of various treatment options. Selection of the most appropriate treatment option is based on performance and cost. Various onsite systems may be synthesized from the data presented in Chapters 5 and 6. As an example of the synthesis of treatment and disposal systems following the detailed site evaluation, assume that all three disposal options selected in 2.2.1.3 proved to be feasible.

Examination of the first two disposal options indicates that only minimal pretreatment may be required. Thus, two systems might be:

1. Septic tank - mounds
2. Septic tank - fill

If groundwater quality is a constraint, however, it may be necessary to develop other systems. Thus, if nitrogen discharges from the disposal system to the groundwater must be controlled, the two treatment-disposal systems may be revised to include the following:

1. Septic tank - mound - denitrification
2. In-house toilet segregation/graywater - septic tank - fill

Note that a variety of other systems may be developed as well. The other disposal option listed in 2.2.1.3 is surface water discharge. Several treatment options exist if the wastewater is disposed of by discharge to surface waters. Filtration and disinfection may be required as part of those treatment options, depending on the water quality requirements of the appropriate regulatory agency.

Residuals produced from the treatment processes also require safe disposal. This must be considered in the selection of the treatment and disposal system. Chapter 9 provides information regarding the character, required treatment, and methods of ultimate disposal of various residuals produced.

2.2.3 System Design

Once all the components are selected, design of the system follows. Chapters 5, 6, 7, 8, and 9 should be consulted for design information.

2.2.4 Onsite System Management

Past experience has shown that onsite management districts have many benefits, including improved site selection, system design, construction, and operation and maintenance. Management districts also facilitate the use of more complex systems or larger systems servicing a cluster of several homes. These districts can take many forms with varying powers. Chapter 10 provides an overview of management options for onsite systems.

CHAPTER 3
SITE EVALUATION PROCEDURES

3.1 Introduction

The environment into which the wastewater is discharged can be a valuable part of an onsite wastewater and disposal system. If utilized properly, it can provide excellent treatment at little cost. However, if stressed beyond its assimilative capacity, the system will fail. Therefore, careful site evaluation is a vital part of onsite system design.

3.2 Disposal Options

In general, facilities designed to discharge partially treated wastewater to the soil for ultimate disposal are the most reliable and least costly onsite systems. This is because little pretreatment of the wastewater is necessary before application to the soil. The soil has a very large capacity to transform and recycle most pollutants found in domestic wastewaters. While the assimilative capacity of some surface waters also may be great, the quality of the wastewater to be discharged into them is usually specified by local water quality regulatory agencies.

To achieve the specified quality may require a more costly treatment system. On the other hand, evaporation of wastewater into the atmosphere requires little wastewater pretreatment, but this method of disposal is severely limited by local climatic conditions. Therefore, the soil should be carefully evaluated prior to the investigation of other receiving environments.

3.2.1 Wastewater Treatment and Disposal by Soil

Soil is the weathered and unconsolidated outer layer of the earth's surface. It is a complex arrangement of primary mineral and organic particles that differ in composition, size, shape, and arrangement. Pores or voids between the particles transmit and retain air and water. Since it is through these pores that the wastewater must pass to be absorbed and treated, their characteristics are important. These are

determined largely by the physical properties of the soil. Descriptions of some of the more important physical properties appear in Appendix A.

The soil is capable of treating organic materials, inorganic substances, and pathogens in wastewater by acting as a filter, exchanger, adsorber, and a surface on which many chemical and biochemical processes may occur. The combination of these processes acting on the wastewater as it passes through the soil produces a water of acceptable quality for discharge into the groundwater under the proper conditions.

Physical entrapment of particulate matter in the wastewater may be responsible for much of the treatment provided by soil. This process performs best when the soil is unsaturated. If saturated soil conditions prevail, the wastewater flows through the larger pores and receives minimal treatment. However, if the soil is kept unsaturated by restricting the wastewater flow into the soil, filtration is enhanced because the wastewater is forced to flow through the smaller pores of the soil.

Because most soil particles and organic matter are negatively charged, they attract and hold positively charged wastewater components and repel those of like charge. The total charge on the surfaces of the soil system is called the cation exchange capacity, and is a good measure of the soil's ability to retain wastewater components. The charged sites in the soil are able to sorb bacteria, viruses, ammonium, nitrogen, and phosphorus, the principal wastewater constituents of concern. The retention of bacteria and viruses allows time for their die-off or destruction by other processes, such as predation by other soil microorganisms (1)(2). Ammonium ions can be adsorbed onto clay particles. Where anaerobic conditions prevail, the ammonium ions may be retained on the particles. If oxygen is present, bacteria can quickly nitrify the ammonium to nitrate which is soluble and is easily leached to the groundwater. Phosphorus, on the other hand, is quickly chemisorbed onto mineral surfaces of the soil, and as the concentration of phosphorus increases with time, precipitates may form with the iron, aluminum, or calcium naturally present in most soils. Therefore, the movement of phosphorus through most soils is very slow (1)(2).

Numerous studies have shown that 2 ft to 4 ft (0.6 to 1.2 m) of unsaturated soil is sufficient to remove bacteria and viruses to acceptable levels and nearly all phosphorus (1)(2). The needed depth is determined by the permeability of the soil. Soils with rapid permeabilities may require greater unsaturated depths below the infiltrative surface than soils with slow permeabilities.

3.2.2 Wastewater Treatment and Disposal by Evaporation

Wastewater can be returned directly to the hydrologic cycle by evaporation. This has appeal in onsite wastewater disposal because it can be used in some areas where site conditions preclude soil absorption or in areas where surface water or groundwater contamination is a concern. The wastewater can be confined and the water removed to concentrate the pollutants within the system. Little or no treatment is required prior to evaporation. However, climatic conditions restrict the application of this method.

Evaporation can take place from a free water surface, bare soil, or plant canopies. Evaporation from plants is called transpiration. Since it is often difficult to separate these two processes on partially bare soil surfaces, they are considered as a single process called evapotranspiration (ET).

If evaporation is to occur continuously, three conditions must be met (3). First, there must be a continuous supply of heat to meet the latent heat requirements of water (approximately 590 cal/gm of water evaporated at 15° C). Second, the vapor pressure in the atmosphere over the evaporative surface must remain lower than the vapor pressure at the surface. This vapor pressure gradient is necessary to remove the moisture either by diffusion, convection, or both. Third, there must be a continuous supply of water to the evaporative surface. The first two conditions are strongly influenced by meteorological factors such as air temperature, humidity, wind velocity, and solar radiation, while the third can be controlled by design.

Successful use of evaporation for wastewater disposal requires that evaporation exceed the total water input to the system. Rates of evaporation decrease dramatically during the cold winter months. In the case of evaporative lagoons or evapotranspiration beds, input from precipitation must also be included. Therefore, application of evaporation for wastewater disposal is largely restricted to areas where evaporation rates exceed precipitation rates. These areas occur primarily in the southwestern United States (see Figure 3-1). In other areas, evaporation can be used to augment percolation into the soil.

Transpiration by plants can be used to augment evaporation in soil-covered systems (5)(6). Plants can transpire at high rates, but only during daylight hours of the growing season. During such periods, evapotranspiration rates may exceed ten times the rates measured in Class A evaporation pans (7)(8)(9). However, overall monthly evaporation rates exceed measured evapotranspiration rates. Ratios of evapotranspiration to evaporation (as measured from Class A pans) are estimated to be 0.75

FIGURE 3-1

POTENTIAL EVAPORATION VERSUS MEAN ANNUAL PRECIPITATION (4)
(inches)

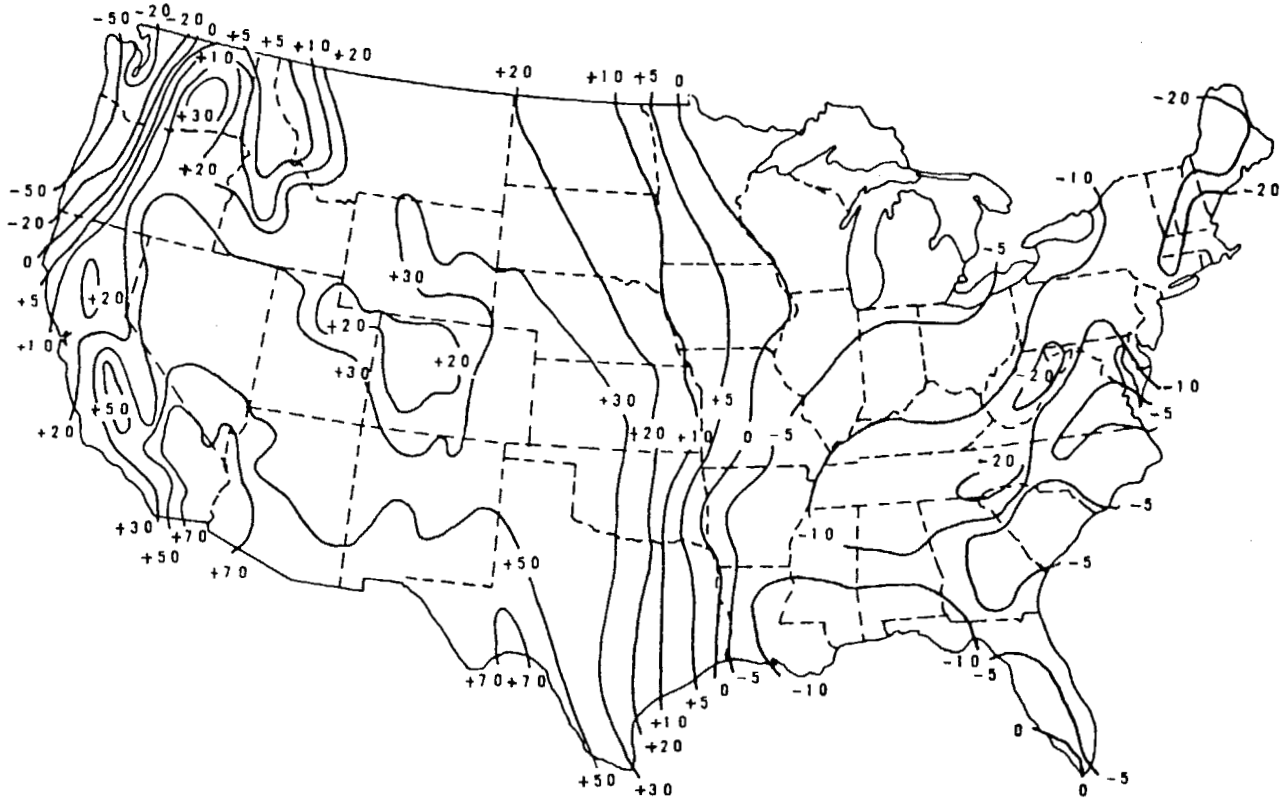

- + Potential Evapotranspiration more than mean annual precipitation
- Potential Evapotranspiration less than mean annual precipitation

to 0.8 (6)(7). Therefore, if covered disposal systems are to be used, they must be larger than systems with a free water surface.

3.2.3 Wastewater Treatment and Disposal in Surface Waters

Surface waters may be used for the disposal of treated wastewaters if permitted by the local regulatory agency. The capacity of surface waters to assimilate wastewater pollutants varies with the size and type of the body of water. In some cases, because of the potential for human contact as well as the concern for maintaining the quality of lakes, streams, and wetlands, the use of such waters for disposal are limited. Where they can be used, the minimum quality of the wastewater effluent to be discharged is specified by the appropriate water quality agency.

3.3 Site Evaluation Strategy

The objective of a site investigation is to evaluate the characteristics of the area for their potential to treat and dispose of wastewater. A good site evaluation is one that provides sufficient information to select the most appropriate treatment and disposal system from a broad range of feasible options. This requires that the site evaluation begin with all options in mind, eliminating infeasible options only as collected site data indicate (see Chapter 2). At the completion of the investigation, final selection of a system from those feasible options is based on costs, aesthetics, and personal preference.

A site evaluation should be done in a systematic manner to ensure the information collected is useful and is sufficient in detail. A suggested procedure is outlined in Table 3-1 and discussed in the following section. This procedure, which can be used to evaluate the feasibility of sites for single dwellings or small clusters of dwellings (up to 10 to 12) is based on the assumption that subsurface soil disposal is the most appropriate method of wastewater disposal. Therefore, the suitability of the soils and other site characteristics for subsurface disposal are evaluated first. If found to be unsuitable, then the site's suitability for other disposal options is evaluated.

TABLE 3-1
SUGGESTED SITE EVALUATION PROCEDURE

<u>Step</u>	<u>Data Collected</u>
Client Contact	Location and description of lot Type of use Volume and characteristics of wastewater
Preliminary Evaluation	Available resource information (soil maps, geology, etc). Records of onsite systems in surrounding area
Field Testing	Topography and landscape features Soil profile characteristics Hydraulic conductivity
Other Site Characteristics	If needed, site suitability for evaporation or discharge to surface waters should be evaluated
Organization of Field Information	Compilation of all data into useable form

3.3.1 Client Contact

Before performing any onsite testing, it is important to gather information about the site that will be useful in evaluating its potential for treating and disposing of wastewater. This begins with the party developing the lot. The location of the lot and the intended development should be established. The volume and character of the generated wastewater should be estimated. Any wastewater constituents that may pose potential problems in treatment and disposal, such as strong organic wastewaters, large quantities of greases, fats or oils, hazardous and toxic substances, etc., should be identified. This information helps to focus the site evaluation on the important site characteristics.

3.3.2 Preliminary Evaluation

The next step is to gather any available resource information about the site. This includes soils, geology, topography, etc., that may be published on maps or in reports. Local records of soil tests, system designs, and reported problems with onsite systems installed in the surrounding area should also be reviewed. This information may lack accuracy, but it can be useful in identifying potential problems or particular features to investigate. A plot plan of the lot and the land immediately adjacent to it should be drawn to a scale large enough so that the information gathered in this and later steps can be displayed on the drawing. The proposed layout of all buildings and other manmade features should also be sketched in.

3.3.2.1 Soil Surveys

Soil surveys are usually found at the local USDA Soil Conservation Service (SCS) office. Also, some areas of the country have been mapped by a state agency and these maps may be located at the appropriate state office. In counties now being mapped, advance field sheets with interpretive tables often can be obtained from the SCS.

Modern soil survey reports are a collection of aerial photographs of the mapping area, usually a county, on which the distribution and kind of soils are indicated. Interpretations about the potential uses of each soil for farming, woodland, recreation, engineering uses, and other nonfarm uses are provided. Detailed descriptions of each soil series found in the area are also given. The maps are usually drawn to a scale of 4 in. to 1 mile. An example of a portion of a soil map is shown in Figure 3-2.

The map symbols for each mapping unit give the name of the soil series, slope, and degree of erosion (10). The soil series name is given a two-letter symbol, the first in upper case, the second in lower case. Slope is indicated by an upper case letter from A to F. A slopes are flat or nearly flat and F slopes are steep. The specific slope range that each letter represents differs from survey to survey. The degree of erosion, if indicated, is given a number representing an erosion class. The classes usually range from 1 to 3, representing slightly eroded to severely eroded phases. The legend for the map symbols is found immediately preceding and following the map sheets in the modern published surveys. An example translation of a map symbol from Figure 3-2 is given in Figure 3-3.

FIGURE 3-2

EXAMPLE OF A PORTION OF A SOIL MAP AS PUBLISHED
IN A DETAILED SOIL SURVEY (ACTUAL SIZE)

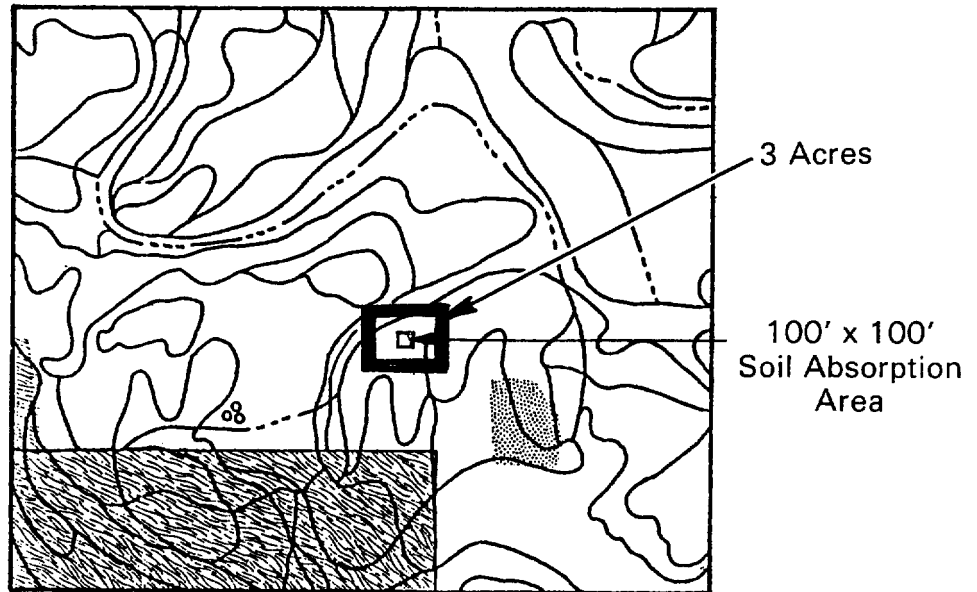
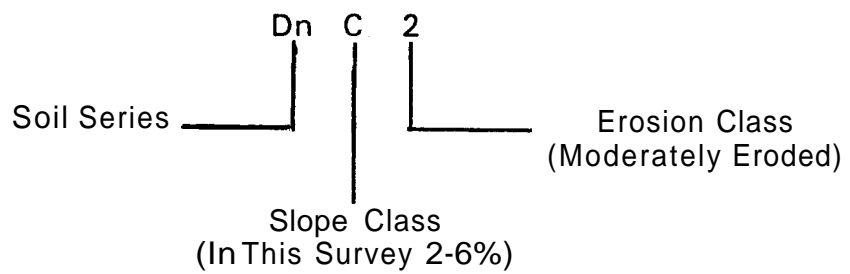

FIGURE 3-3

TRANSLATION OF TYPICAL SOIL MAPPING UNIT SYMBOL



Interpretations about potential uses of each soil series are listed in tables within the text of the report. The soil's suitability for subsurface soil absorption systems and lagoons are specifically indicated. Engineering properties are also listed, often including depth to bedrock, seasonal high water table, percolation rate, shrink-swell potential, drainage potential, etc. Flooding hazard and other important factors are discussed for each mapping unit with the profile descriptions.

While the soil surveys offer good preliminary information about an area, it is not complete nor a substitute for a field study. Because of the scale used, the mapping units cannot represent areas smaller than 2 to 3 acres (8,100 to 12,100 m²). Thus, there may be inclusions of soils with significantly different character within mapping units that cannot be indicated. For typical building lots, the map loses accuracy. Therefore, these maps cannot be substituted for onsite testing in most cases.

Limitation ratings used by SCS for septic tank-soil absorption systems are based on conventional trench or bed designs, and thus do not indicate the soil's suitability for other designs. Table 3-2 lists the criteria used in making the limitation ratings. They are based on a soil absorption system with the bottom surface located 2 ft (0.6 m) below the soil surface. In many cases, the limitations can be overcome through proper design. Therefore, the interpretations should be used only as a guide.

The information provided by the soil survey should be transferred to the site drawing along with other important information. An example for a parcel is shown in Figure 3-4. Information for each of the soil sites shown on Figure 3-4 is presented in Table 3-3.

3.3.2.2 U.S. Geological Survey Quadrangles

Quadrangles published by the U.S. Geological Survey may be useful in estimating slope, topography, local depressions or wet areas, rock outcrops, and regional drainage patterns and water table elevations. These maps are usually drawn to a scale of 1:24,000 (7.5 minute series) or 1:65,000 (15 minute series). However, because of their scale, they are of limited value for evaluating small parcels.

TABLE 3-2

SOIL LIMITATIONS RATINGS USED BY SCS
FOR SEPTIC TANK/SOIL ABSORPTION FIELDS
[Modified after (10)]

Property	Limits			Restrictive Feature
	Slight	Moderate	Severe	
USDA Texture	----	----	Ice	Permafrost
Flooding	None, Protected	Rare	Common	Floods
Depth to Bedrock, in.	>72	40-72	<40	Depth to Rock
Depth to Cemented Pan, in.	>72	40-72	<40	Depth to Cemented Pan
Depth to High Water Table, ft below ground	>6	4-6	<4	Ponding, Wetness
Permeability, in./hr 24-60 in. layer layers <24 in.	2.0-6.0 ---	0.6-2.0 ---	<0.6	Slow Perc. Rate Poor Filter
Slope, percent	0-8	8-15	>15	Slope
Fraction >3 in., percent by wt	<25	25-50	>50	Large Stones

3.3.2.3 Local Records

Soil test reports and records of reported failure of onsite systems from the surrounding area may be a source of valuable information. The soil test reports can provide an indication of soil types and variability. Performance of systems may be determined from the reported failures. These records are usually available from the local regulatory agency,

FIGURE 3-4

PLOT PLAN SHOWING SOIL SERIES BOUNDARIES
FROM SOIL SURVEY REPORT

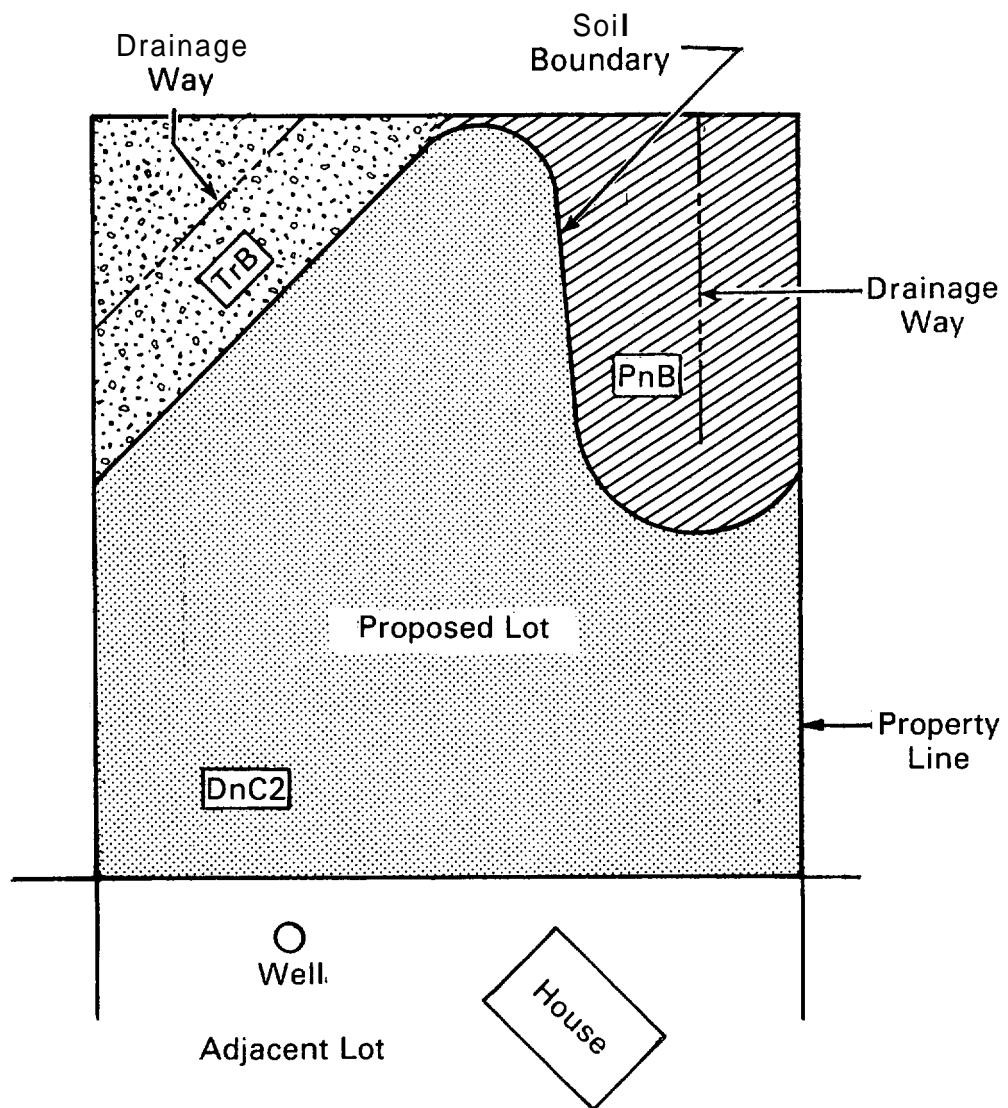

TABLE 3-3

SOIL SURVEY REPORT INFORMATION
FOR PARCEL IN FIGURE 3-4

Map Symbol	Soil Series	Slope %	Soil	Flood	Depth to	Depth to	Permeability	
			Absorption Limitation Rating				Hazard	High Water Table ft
DnC2	Dodge	2-6	Moderate	No	>5	5-10	0-40	0.63-2.0
							40-60	2.0-6.3
TrB	Troxel	2-6	Severe	Yes	3-5	>10	0-60	0.63-20
PnB	Plano	2-6	Moderate	No	3-5	>10	0-41	0.63-2.0
							41-60	2.0-6.3

3.3.3 Field Testing

Field testing begins with a visual survey of the parcel to locate potential sites for subsurface soil absorption. Soil borings are made in the potential sites to observe the soil characteristics. Percolation tests may be conducted in those soils that appear to be well suited. If no potential sites can be found from either the visual survey, soil borings, or percolation tests, then other means of disposal should be investigated.

3.3.3.1 Visual Survey

A visual survey is made to locate the areas on the lot with the greatest potential for subsurface soil absorption. The location of any depressions, gullies, steep slopes, rocks or rock outcrops, or other obvious land and surface features are noted and marked on the plot plan. Vegetation types are also noted that may indicate wetness or shallow soils. Locations and distances from a permanent benchmark to lot lines, wells, surface waters, buildings, and other features or structures are also marked on the plot plan (see Figure 3.5). If a suitable area cannot be

FIGURE 3-5

PLOT PLAN SHOWING SURFACE FEATURES

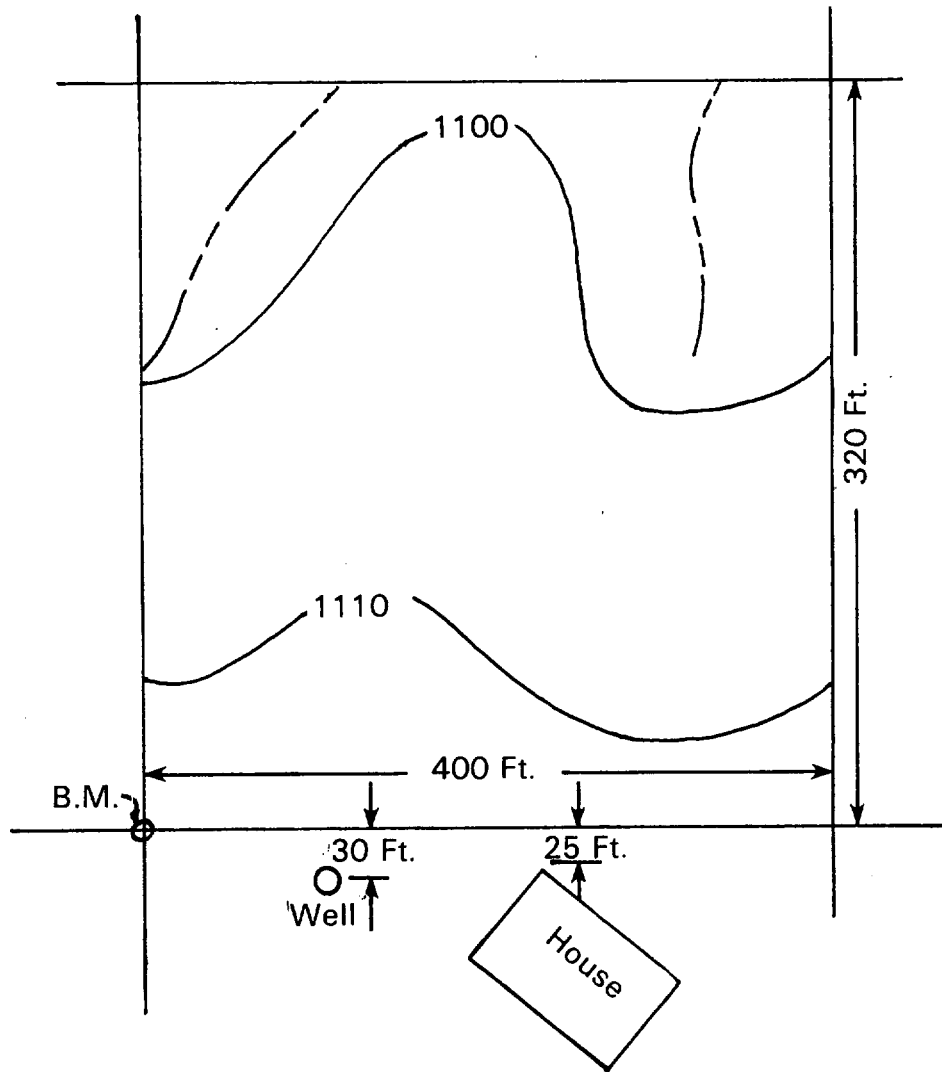

found for a subsurface soil absorption system based on this information other disposal options must be considered (see Chapter 2). The remainder of the field testing can be altered accordingly.

3.3.3.2 Landscape Position

The landscape position and landform for each suitable area should be noted. Figure 3-6 can be used as a guide for identifying landscape positions. This information is useful in estimating surface and subsurface drainage patterns. For example, hilltops and sideslopes can be expected to have good surface and subsurface drainage, while depressions and footslopes are more likely to be poorly drained.

3.3.3.3 Slope

The type and degree of slope of the area should be determined. The type of slope indicates what surface drainage problems may be expected. For example, concave slopes cause surface runoff to converge, while convex slopes disperse the runoff (see Figure 3-6).

Some treatment and disposal systems are limited by slopes. Therefore, slope measurement is important. Land slopes can be expressed in several ways (see Figure 3-7):

1. PERCENT OF GRADE - The feet of vertical rise or fall in 100 ft horizontal distance.
2. SLOPE - The ratio of vertical rise or fall to horizontal distance.
3. ANGLE - The degrees and minutes from horizontal.
4. TOPOGRAPHIC ARC - The feet of vertical rise or fall in 66 ft (20 m) horizontal distance.

Land slopes are usually determined by measuring the slope of a line parallel to the ground with an Abney Level either at eye height or at some other fixed height above the ground. If an ordinary hand level is used, then slopes are determined by horizontal line of sight which give changes in elevation for specific horizontal distances. A hand level is limited in use because it is best suited for slope determinations up grade only, but has the advantage that only one person is needed for mapping slopes. Three methods of slope determinations are discussed below.

FIGURE 3-6
LANDSCAPE POSITIONS

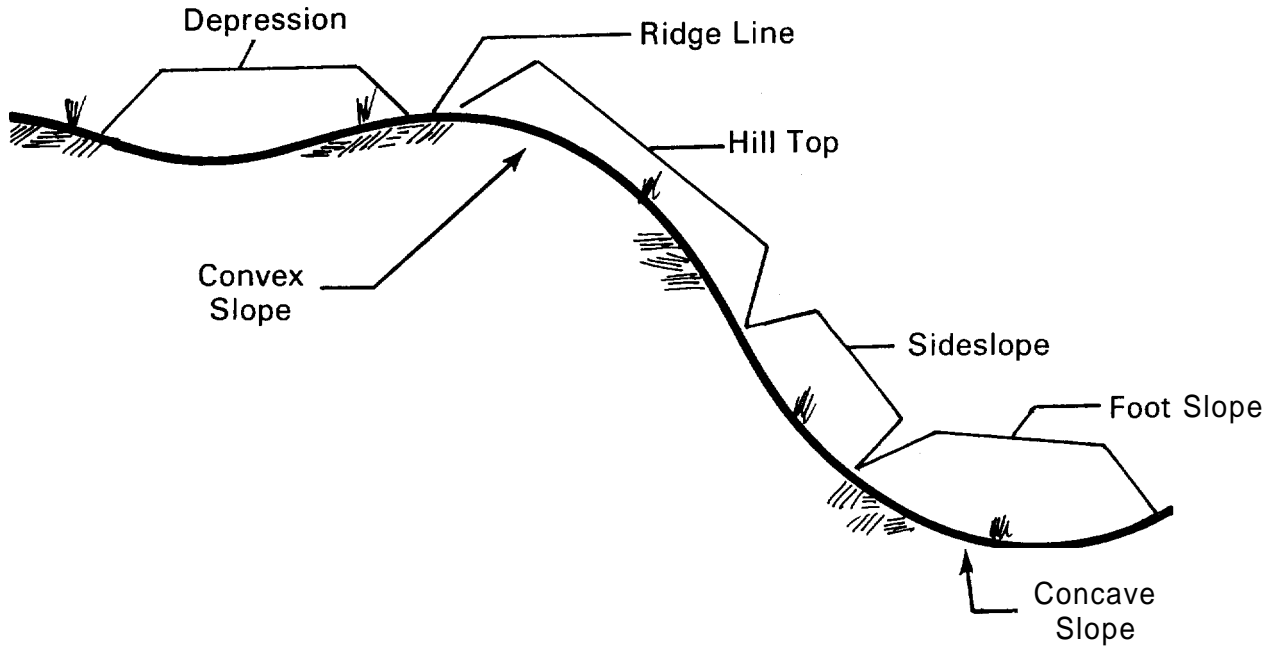
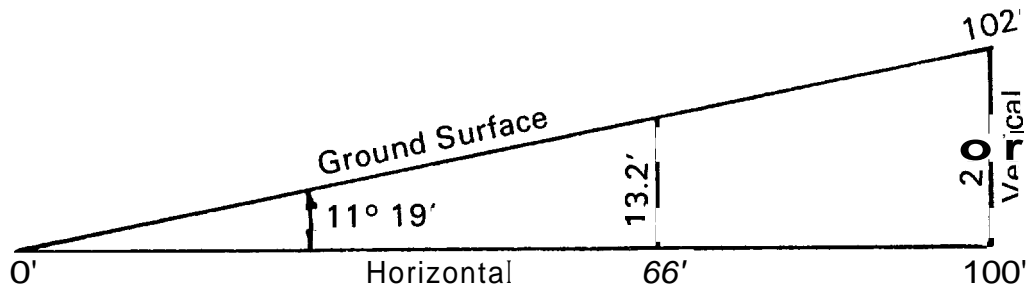

FIGURE 3-7
METHODS OF EXPRESSING LAND SLOPES (10)



Percent of Grade - 20
Slope-1:5
Angle - 11° 19'
Topographic Arc - 13.2

Instrument Supported - Abney Level : For accurate slope determinations, notch two sticks or cut forked sticks so they will hold the level 5 ft (1.5 m). above the ground. Rest the level in the notch or fork and sight to the notch or fork of the other stick held by another person at a point on the slope. The land slope is read directly in percent on the Abney Level.

Abney Level: On level ground, sight the person working with you to determine the point of intersection of your line of sight on him when the instrument is in position for use as a hand level (zero level position). When he is on the slope, sight the same point on the person assisting you and read the slope directly.

Hand Level: Height of eye must be determined. Then sight the point of interception with the ground surface and determine, by tape measurement or pacing, the ground surface distance between the sighting point and the point of intercept. To calculate land slope in percent, divide your height of eye by the ground surface distance and multiply by 100.

Using one of the above procedures or other surveying methods, slopes at selected sites can be determined so that topography can be mapped. The number of sites needed will depend on the complexity of slopes. Slope determinations should be made at each apparent change in slope at known locations so steep slope areas can be accurately drawn. Experience will be required for proficiency and accuracy in mapping. Steep slope areas in natural topography have irregular form and curved boundaries. Uniform boundaries having straight lines and angular corners indicate man-altered conditions. For large areas it may be necessary to draw contour lines so that slopes at different points in the plot can be determined.

3.3.3.4 Soil Borings

Observation and evaluation of soil characteristics can best be determined from a pit dug by a backhoe or other excavating equipment. However, an experienced soil tester can do a satisfactory job by using a hand auger or probe. Both methods are suggested. Hand tools can be used to determine soil variability over the area and pits used to describe the various soil types found.

Soil pits should be prepared at the perimeter of the expected soil absorption area. Pits prepared within the absorption area often settle after the system has been installed and may disrupt the distribution network. If hand augers are used, the holes may be made within the

absorption area. Sufficient borings or pits should be made to adequately describe the soils in the area, and should be deep enough to assure that a sufficient depth of unsaturated soil exists below the proposed bottom elevation of the absorption area. Variable soil conditions may require many pits.

Since in some cases subtle differences in color need to be recognized, it is often advantageous to prepare the soil pit so the sun will be shining on the face during the observation period. Natural light will give true color interpretations. Artificial lighting should not be used.

3.3.3.5 Soil Texture

Texture is one of the most important physical properties of soil because of its close relationship to pore size, pore size distribution, and pore continuity. It refers to the relative proportion of the various sizes of solid particles in the soil that are smaller than 2 mm in diameter. The soil texture is determined in the field by rubbing a moist sample between the thumb and forefinger. A water bottle is useful for moisturizing the sample. The grittiness, "silkeness," or stickiness can be interpreted as being caused by the soil separates of sand, silt, and clay. It is extremely helpful to work with some known samples to gain experience with field texturing.

While laboratory analysis of soil texture is done routinely by many laboratories, field texturing can give as good information as laboratory data and therefore expenditures of time and money for laboratory analyses are not necessary. To determine the soil texture, moisten a sample of soil about one-half to one inch in diameter. There should be just enough moisture so that the consistency is like putty. Too much moisture results in a sticky material, which is hard to work. Press and squeeze the sample between the thumb and forefinger. Gradually press the thumb forward to try to form a ribbon from the soil (see Figure 3-8). By using this procedure, the texture of the soil can be easily described.

Table 3-4 and Figures 3-9 and 3-10 describe the feeling and appearance of the various soil textures for a general soil classification.

FIGURE 3-8

PREPARATION OF SOIL SAMPLE FOR FIELD
DETERMINATION OF SOIL TEXTURE



(A) Moistening Sample



(B) Forming Cast



(C) Ribboning

TABLE 3-4
TEXTURAL PROPERTIES OF MINERAL SOILS

<u>Soil Class</u>	<u>Feeling and Appearance</u>	
	<u>Dry Soil</u>	<u>Moist Soil</u>
Sand	Loose, single grains which feel gritty. Squeezed in the hand, the soil mass falls apart when the pressure is released.	Squeezed in the hand, it forms a cast which crumbles when touched. Does not form a ribbon between thumb and forefinger.
Sandy Loam	Aggregates easily crushed; very faint velvety feeling initially but with continued rubbing the gritty feeling of sand soon dominates.	Forms a cast which bears careful handling without breaking. Does not form a ribbon between thumb and forefinger.
Loam	Aggregates are crushed under moderate pressure; clods can be quite firm. When pulverized, loam has velvety feel that becomes gritty with continued rubbing. Casts bear careful handling.	Cast can be handled quite freely without breaking. Very slight tendency to ribbon between thumb and forefinger. Rubbed surface is rough.
Silt Loam	Aggregates are firm but may be crushed under moderate pressure. Clods are firm to hard. Smooth, flour-like feel dominates when soil is pulverized.	Cast can be freely handled without breaking. Slight tendency to ribbon between thumb and forefinger. Rubbed surface has a broken or rippled appearance.
Clay Loam	Very firm aggregates and hard clods that strongly resist crushing by hand. When pulverized, the soil takes on a somewhat gritty feeling due to the harshness of the very small aggregates which persist.	Cast can bear much handling without breaking. Pinched between the thumb and forefinger, it forms a ribbon whose surface tends to feel slightly gritty when dampened and rubbed. Soil is plastic, sticky and puddles easily.
Clay	Aggregates are hard; clods are extremely hard and strongly resist crushing by hand. When pulverized, it has a grit-like texture due to the harshness of numerous very small aggregates which persist.	Casts can bear considerable handling without breaking. Forms a flexible ribbon between thumb and forefinger and retains its plasticity when elongated. Rubbed surface has a very smooth, satin feeling. Sticky when wet and easily puddled.

FIGURE 3-9

SOIL TEXTURE DETERMINATION BY HAND: PHYSICAL APPEARANCE OF VARIOUS SOIL TEXTURES







	Dry	Moist
Sandy Loam	 Weak Aggregates	 No Ribbon; Non-Plastic Cast
Silt Loam	 Firm Aggregates	 Very Slight Ribbing Tendency; Moderately Plastic Cast
Clay	 Hard Aggregates	 Ribbons Easily; Plastic Cast

FIGURE 3-10

COMPARISON OF RIBBONS AND CASTS OF SANDY LOAM
AND CLAY (RIBBONS ABOVE, CASTS BELOW)



If the soil sample ribbons (loam, clay loam, or clay), it may be desirable to determine if sand or silt predominate. If there is a gritty feel and a lack of smooth talc-like feel, then sand very likely predominates. If there is a lack of a gritty feel but a smooth talc-like feel, then silt predominates. If there is not a predominance of either the smooth or gritty feel, then the sample should not be called anything other than a clay, clay loam, or loam. If a sample feels quite smooth with little or no grit in it, and will not form a ribbon, the sample would be called silt loam.

Beginning at the top or bottom of the pit sidewall, obvious changes in texture with depth are noted. Boundaries that can be seen are marked. The texture of each layer or horizon is determined and the demarcations of boundaries changed as appropriate. When the textures have been determined for each layer, the depth, thickness, and texture of each layer is recorded (see Figure 3-11).

3.3.3.6 Soil Structure

Soil structure has a significant influence on the soil's acceptance and transmission of water. Soil structure refers to the aggregation of soil particles into clusters of particles, called peds, that are separated by surfaces of weakness. These surfaces of weakness open planar pores between the peds that are often seen as cracks in the soil. These planar pores can greatly modify the influence of soil texture on water movement. Well-structured soils with large voids between peds will transmit water more rapidly than structureless soils of the same texture, particularly if the soil has become dry before the water is added. Fine-textured, massive soils (soils with little structure) have very slow percolation rates.

FIGURE 3-11

EXAMPLE PROCEDURE FOR COLLECTING
SOIL PIT OBSERVATION INFORMATION

Depth (Ft.)	Texture	Structure	Color	Soil Saturation
0	Silt Loam	Granular	Brown	None
		Platy		
2	Silty Clay Loam	Blocky		
	Clay Loam			
4	Sandy Loam	Platy		
6	↓	Massive		
8				
10				
12				
14				

If a detailed analysis of the soil structure is necessary, the sidewall of the soil pit should be carefully examined, using a pick or similar device to expose the natural cleavages and planes of weakness. Cracks in the face of the soil profile are indications of breaks between soil peds. The shapes created by the cracks should be compared to the shapes shown in Figure 3-12. If cracks are not visible, a sample of soil should be carefully picked out and, by hand, carefully separated into the structural units until any further breakdown can only be achieved by fracturing.

Since the structure can significantly alter the hydraulic characteristics of soils, more detailed descriptions of soil structure are sometimes desirable. Size and grade of durability of the structural units provide useful information to estimate hydraulic conductivities. Descriptions of types and classes of soil structure used by SCS are given in Appendix A. Grade descriptions are given in Table 3-5. The type, size, and grade of each horizon or zone is recorded in Figure 3-11.

3.3.3.7 Soil Color

The color and color patterns in soil are good indicators of the drainage characteristics of the soil. Soil properties, location in the landscape, and climate all influence water movement in the soil. These factors cause some soils to be saturated or seasonally saturated, affecting their ability to absorb and treat wastewater. Interpretation of soil color aids in identifying these conditions.

Color may be described by estimating the true color for each horizon or by comparing the soil with the colors in a soil color book. In either case, it is particularly important to note the colors or color patterns.

Pick up some soil and, without crushing, observe the color. It is important to have good sunlight and know the moisture status of the sample. If ped faces are dry, some water applied from a mist bottle will allow observation of moist colors.

Though it is often adequate to speak of soil colors in general terms, there is a standard method of describing colors using Munsell color notation. This notation is used in soil survey reports and soil description. Hue is the dominant spectral color and refers to the lightness or darkness of the color between black and white. Chroma is the relative purity or strength of the color, and ranges from gray to a bright color of that hue. Numbers are given to each of the variables and a verbal description is also given. For example, 10YR 3/2 corresponds to a color hue of 10YR value of 3 and chroma 2. This is a very dark grayish brown.

FIGURE 3-12

TYPES OF SOIL STRUCTURE

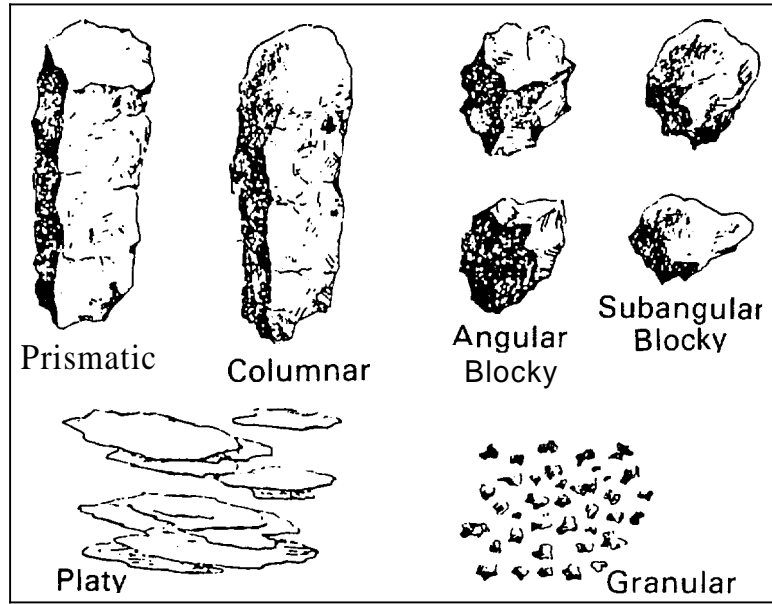

TABLE 3-5

GRADES OF SOIL STRUCTURE

<u>Grade</u>	<u>Characteristics</u>
Structureless	No observable aggregation.
Weak	Poorly formed and difficult to see. Will not retain shape on handling.
Moderate	Evident but not distinct in undisturbed soil. Moderately durable on handling.
Strong	Visually distinct in undisturbed soil. Durable on handling.

If a soil color book is used to determine soil colors, hold the soil and book so the sun shines over your shoulder. Match the soil color with the color chip in the book. Record the hue, chroma and value, and the color name.

Mottling in soils is described by the color of the soil matrix and the color or colors, size, and number of the mottles. Each color may be given a Munsell designation and name. However, it is often sufficient to say the soil is mottled. A classification of mottles used by the USDA is shown in Table 3-6. Some examples of soil mottling are shown on the inside back cover of this manual.

TABLE 3-6
DESCRIPTION OF SOIL MOTTLES (10)

<u>Character</u>	<u>Class</u>	<u>Limit</u>
Abundance	Few	<2% of exposed face
	Common	2-20% of exposed face
	Many	>20% of exposed face
Size	Fine	<5mm longest dimension
	Medium	5-15mm longest dimension
	Coarse	>15mm longest dimension
Contrast	Faint	Recognized only by close observation
	Distinct	Readily seen but not striking
	Prominent	Obvious and striking

3.3.3.8 Seasonally Saturated Soils

Seasonally saturated soils can usually be detected by soil borings made during the wet season or by the presence of mottled soils (see 3.3.3.7). For large cluster systems or for developments where each dwelling is served by an onsite system, the use of observation wells may be justified. They are constructed as shown in Figure 3-13. The well should be placed in, but not extended through, the horizon that is to be monitored. More than one well in each horizon that may become seasonally saturated is desirable. The wells are monitored over a normal wet season by observing the presence and duration of water in the well. If water remains in the well for several days, the water level elevation is measured and assumed to be the elevation of the seasonally saturated soil horizon.

FIGURE 3-13

TYPICAL OBSERVATION WELL FOR DETERMINING SOIL SATURATION

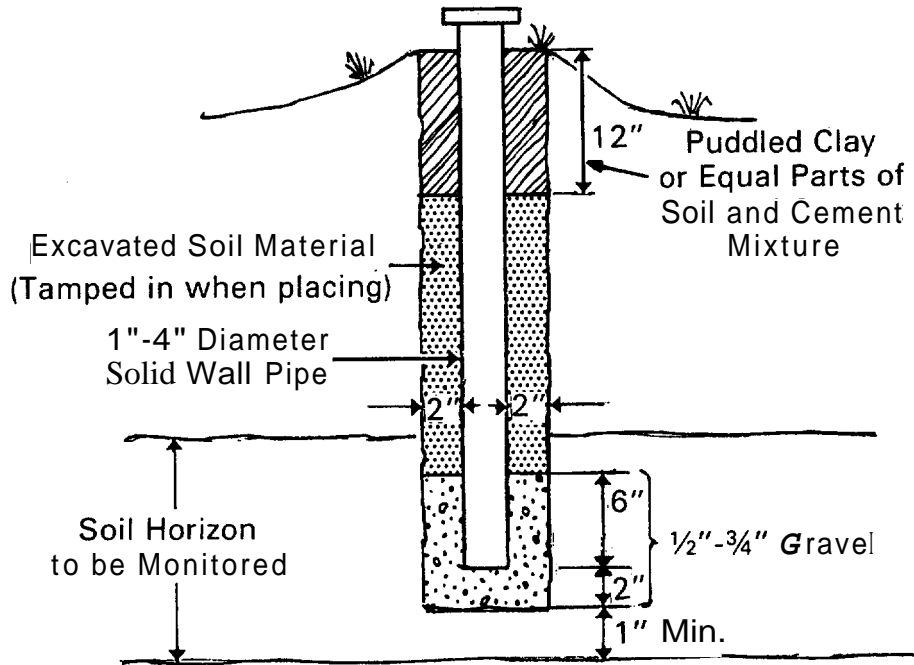

3.3.3.9 Other Selected Soil Characteristics

Soil bulk density is related to porosity and the movement of water. High bulk density is an indication of low porosity and restricted flow of water. Relative bulk densities of different soil horizons can be detected in the field by pushing a knife or other instrument into each horizon. If one horizon offers considerably more resistance to penetration than the others, its bulk density is probably higher. However, in some cases, cementing agents between soil grains or peds may be the cause of resistance to penetration.

Swelling clays, particularly montmorillonite clays, can seal off soil pores when wet. They can be detected during field texturing of the soil by their tendency to be more sticky and plastic when wet.

3.3.3.10 Hydraulic Conductivity

Several methods of measuring the hydraulic conductivity of soils have been developed (1)(11). The most commonly used test is the percolation test. When run properly, the test can give an approximate measure of the soil's saturated hydraulic conductivity. However, the percolation of wastewater through soil below soil disposal systems usually occurs through unsaturated soils. Therefore, empirical factors must be used to estimate unsaturated conductivities. The unsaturated hydraulic conductivity ties can vary dramatically from the saturated hydraulic conductivity with changes in soil characteristics and moisture content (see Appendix A).

The percolation test is often criticized because of its variability and failure to measure the hydraulic conductivity accurately. Percolation tests conducted in the same soils can vary by 90% or more (1)(11)(12)(13)(14). Reasons for the large variability are attributed to the procedure used, the soil moisture conditions at the time of the test, and the individual performing the test. Despite these shortcomings, the percolation test can be useful if used together with the soil borings data. The test can be used to rank the relative hydraulic conductivity of the soil. Estimated percolation rates for various soil textures are given in Table 3-7.

TABLE 3-7

ESTIMATED HYDRAULIC CHARACTERISTICS OF SOIL (15)

<u>Soil Texture</u>	<u>Permeability</u> in. /hr	<u>Percolation</u> min/in.
Sand	>6.0	<10
Sandy loams Porous silt loams Silty clay loams	0.2-6.0	10-45
Clays, compact Silt loams Silty clay loams	<0.2	>45

If test results agree with this table, the test and boring data are probably correct and can be used in design. If not, either the test was run improperly or soil structure or clay mineralogy have a significant effect on the hydraulic conductivity. For example, if the texture of a soil is determined to be a clay loam, the estimated percolation rate is slower than 45 min/in. (18 min/cm). If the measured percolation rate is 15 min/in. (6 min/cm), however, either the texture is incorrect or the soil has strong structure with large cracks between peds. The tester should be cautious in such soils because the unsaturated hydraulic conductivity may be many times less. Expandable clays may be present that could close many of the pores.

Several percolation test procedures are used (11)(16). The most common procedure is the falling head test (11). Though less reproducible than other procedures, it is simple to perform in the field (11)(12). The falling head procedure is outlined in Table 3-8. A diagram of a "percometer" designed to simplify the testing is illustrated in Figure 3-14. For a discussion of other methods see the National Environmental Health Association's "On-Site Wastewater Management" (16).

Data collected from the percolation test can be tabulated using a form similar to the one illustrated in Figure 3-15.

3.3.4 Other Site Characteristics

If subsurface disposal does not appear to be a viable option or cost-effective, other methods of disposal are evaluated (see Chapter 2). Evaporation and discharge to surface waters are other options to investigate. Each requires further site evaluation.

3.3.4.1 Site Evaluation of Evaporation Potential

Evaporation and evapotranspiration can be used as the sole means of disposal or as a supplement to soil absorption. To be effective, evaporation should exceed precipitation in the area. The difference between evaporation and precipitation rates provides estimates of quantities of water that can be evaporated from a free water surface.

Weather data can be obtained from local weather stations and the National Oceanic and Atmosphere Administration (NOAA). Rainfall and snowfall measurements are available from NOAA for thousands of weather stations throughout the country. Many local agencies also maintain records. A critical wet year is typically used for design based on at least 10 years of records (18).

TABLE 3-8
FALLING HEAD PERCOLATION TEST PROCEDURE

1. Number and Location of Tests

Commonly a minimum of three percolation tests are performed within the area proposed for an absorption system. They are spaced uniformly throughout the area. If soil conditions are highly variable, more tests may be required.

2. Preparation of Test Hole

The diameter of each test hole is 6 in., dug or bored to the proposed depths at the absorption systems or to the most limiting soil horizon. To expose a natural soil surface, the sides of the hole are scratched with a sharp pointed instrument and the loose material is removed from the bottom of the test hole. Two inches of 1/2 to 3/4 in. gravel are placed in the hole to protect the bottom from scouring action when the water is added.

3. Soaking Period

The hole is carefully filled with at least 12 in. of clear water. This depth of water should be maintained for at least 4 hr and preferably overnight if clay soils are present. A funnel with an attached hose or similar device may be used to prevent water from washing down the sides of the hole. Automatic siphons or float valves may be employed to automatically maintain the water level during the soaking period. It is extremely important that the soil be allowed to soak for a sufficiently long period of time to allow the soil to swell if accurate results are to be obtained.

In sandy soils with little or no clay, soaking is not necessary. If, after filling the hole twice with 12 in. of water, the water seeps completely away in less than ten minutes, the test can proceed immediately.

4. Measurement of the Percolation Rate

Except for sandy soils, percolation rate measurements are made 15 hr but no more than 30 hr after the soaking period began. Any soil that sloughed into the hole during the soaking period is removed and the water level is adjusted to 6 in. above the gravel (or 8 in. above the bottom of the hole). At no time during the test is the water level allowed to rise more than 6 in. above the gravel.

Immediately after adjustment, the water level is measured from a fixed reference point to the nearest 1/16 in. at 30 min intervals. The test is continued until two successive water level drops do not vary by more than 1/16 in. At least three measurements are made.

After each measurement, the water level is readjusted to the 6 in. level. The last water level drop is used to calculate the percolation rate.

In sandy soils or soils in which the first 6 in. of water added after the soaking period seeps away in less than 30 min, water level measurements are made at 10 min intervals for a 1 hr period. The last water level drop is used to calculate the percolation rate.

5. Calculation of the Percolation Rate

The percolation rate is calculated for each test hole by dividing the time interval used between measurements by the magnitude of the last water level drop. This calculation results in a percolation rate in terms of min/in. To determine the percolation rate for the area, the rates obtained from each hole are averaged. (If tests in the area vary by more than 20 min/in., variations in soil type are indicated. Under these circumstances, percolation rates should not be averaged.)

Example: If the last measured drop in water level after 30 min is 5/8 in., the percolation rate = (30 min)/(5/8 in.) = 48 min/in.)

FIGURE 3-14
CONSTRUCTION OF A PERCOMETER

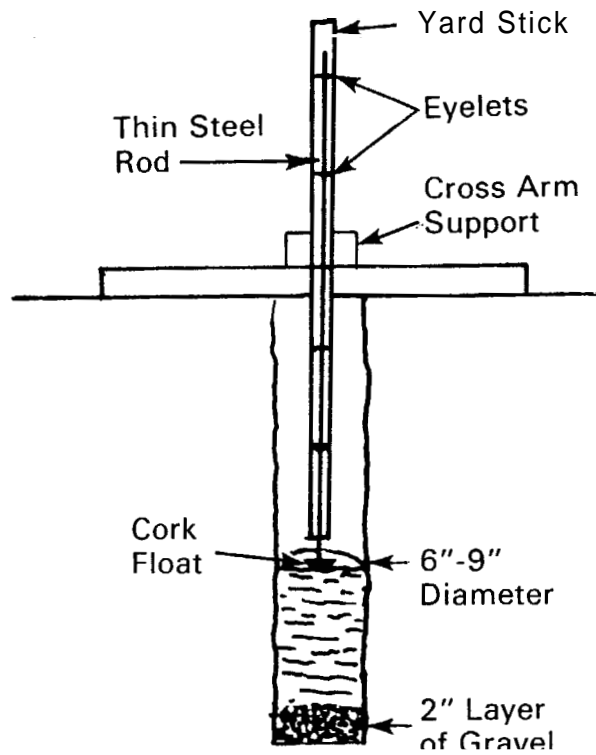

(a) Floating Indicator

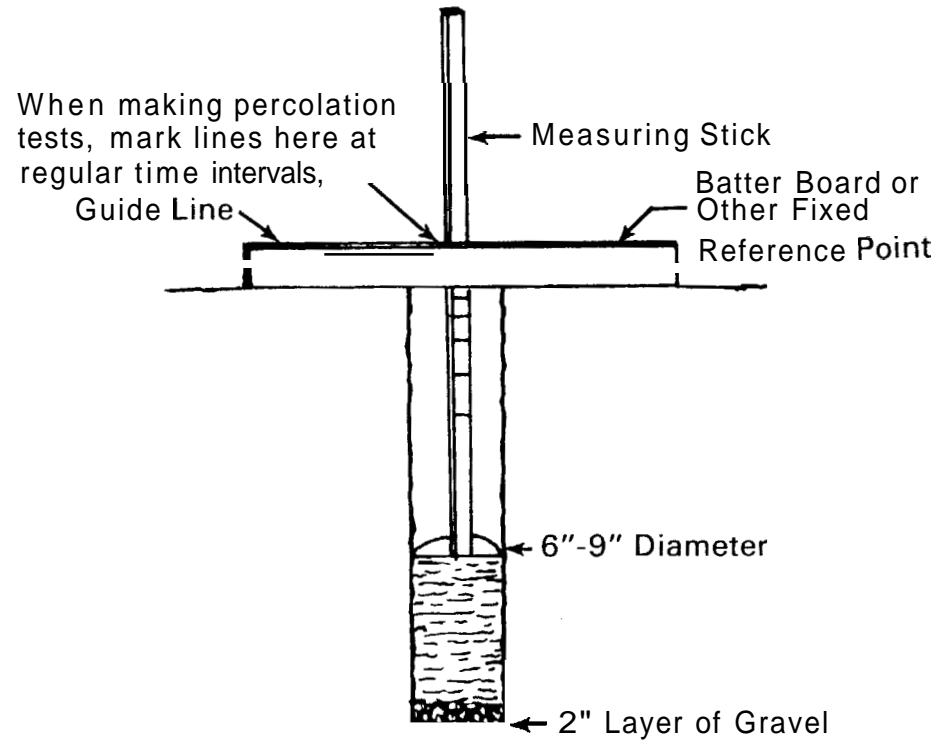

(b) Fixed Indicator

FIGURE 3-15

PERCOLATION TEST DATA FORM (17)

Percolation test

Location Lot 105, High Point Heights Subdivision

Test hole number 3

Depth to bottom of hole 28 inches. Diameter of hole 6 inches.

Depth, inches	Soil texture
<u>0-4</u>	<u>blk top soil</u>
<u>4-12</u>	<u>brn sl</u>
<u>12-28</u>	<u>brn scl</u>

Percolation test by C. J. Tester

Date of test 6/28/80

Time	Time Interval, minutes	Measurement, inches	Drop in water level, inches	Percolation rate, minutes per inch	Remarks
<u>9:30</u>	<u>-</u>	<u>44</u>	<u>-</u>		
<u>10:00</u>	<u>30</u>	<u>43</u>	<u>1</u>		
<u>10:20</u>	<u>20</u>	<u>43</u>	<u>1</u>		
<u>10:50</u>	<u>30</u>	<u>43 1/4</u>	<u>3/4</u>		
<u>11:20</u>	<u>30</u>	<u>43 1/16</u>	<u>15/16</u>		
<u>12:00</u>	<u>40</u>	<u>43 1/4</u>	<u>3/4</u>		
<u>12:30</u>	<u>30</u>	<u>43 3/16</u>	<u>13/16</u>		
<u>1:00</u>	<u>30</u>	<u>43 5/16</u>	<u>11/16</u>		
<u>1:30</u>	<u>30</u>	<u>43 5/16</u>	<u>11/16</u>	<u>44</u>	

Percolation rate = 44 minutes per inch.

Establishing evaporation data at a specific location can be a more difficult problem. Measurements of Class A pan evaporation rates are reported for all of the states by NOAA in the publication, "Climatological Data," U.S. Department of Commerce, available in depository libraries for government documents at major universities in each state. Pan evaporation measurements are made at a few (5 to 30) weather stations in each state. Data for the winter months are often omitted because this method cannot be used under freezing weather conditions. The critical period of the year for design of systems for permanent homes is in the winter. Obtaining representative winter evaporation data is probably the most difficult part of design analysis. Application of evaporation systems is most favorable in the warm, dry climates of the southwestern United States. For these areas, pan evaporation data are available for the complete year. The analysis of evaporative potential for cooler, semi-arid regions, such as eastern Washington and Oregon, Utah, Colorado, and similar areas, requires that winter data be established by means other than pan evaporation measurements, since these data are generally not available.

One method for establishing representative winter evaporation data is to take measurements on buried lysimeters. Another method is to use empirical formulations such as the Penman formula (18). The Penman formula has been shown to give results comparable to measured winter values (5).

3.3.4.2 Site Evaluation for Surface Water Discharge

For surface water disposal to be a viable option, access to a suitable surface body of water must be available. Onsite investigations must locate the body of water, identify it, and determine the means by which access can be gained. Since discharges to surface waters are usually regulated, the local water quality agency must be contacted to learn if discharge of wastewater into that body of water is permitted and, if so, what effluent standards must be met.

3.3.5 Organizing the Site Information

As the site information is collected, it is organized so that it can be easily used to check site suitability for any of the various systems discussed in this manual. One such method of organization is shown in Figure 3-16. In this example, two soil observations have been made. The number of soil observations varies. It is important that all pertinent site information be presented in a clear fashion to provide sufficient information to the designer of the system without making additional site visits.

FIGURE 3-16

COMPILATION OF SOILS AND SITE INFORMATION
(INFORMATION INCLUDES TOPOGRAPHIC, SOIL SURVEY,
ONSITE SLOPE AND SOIL PIT OBSERVATIONS)

Name T. B. Resident Site evaluator C.J. Tester

Address LOT 105, High Points Heights Address Lake City, U.S.A.

Waste water quantity 450 gpd

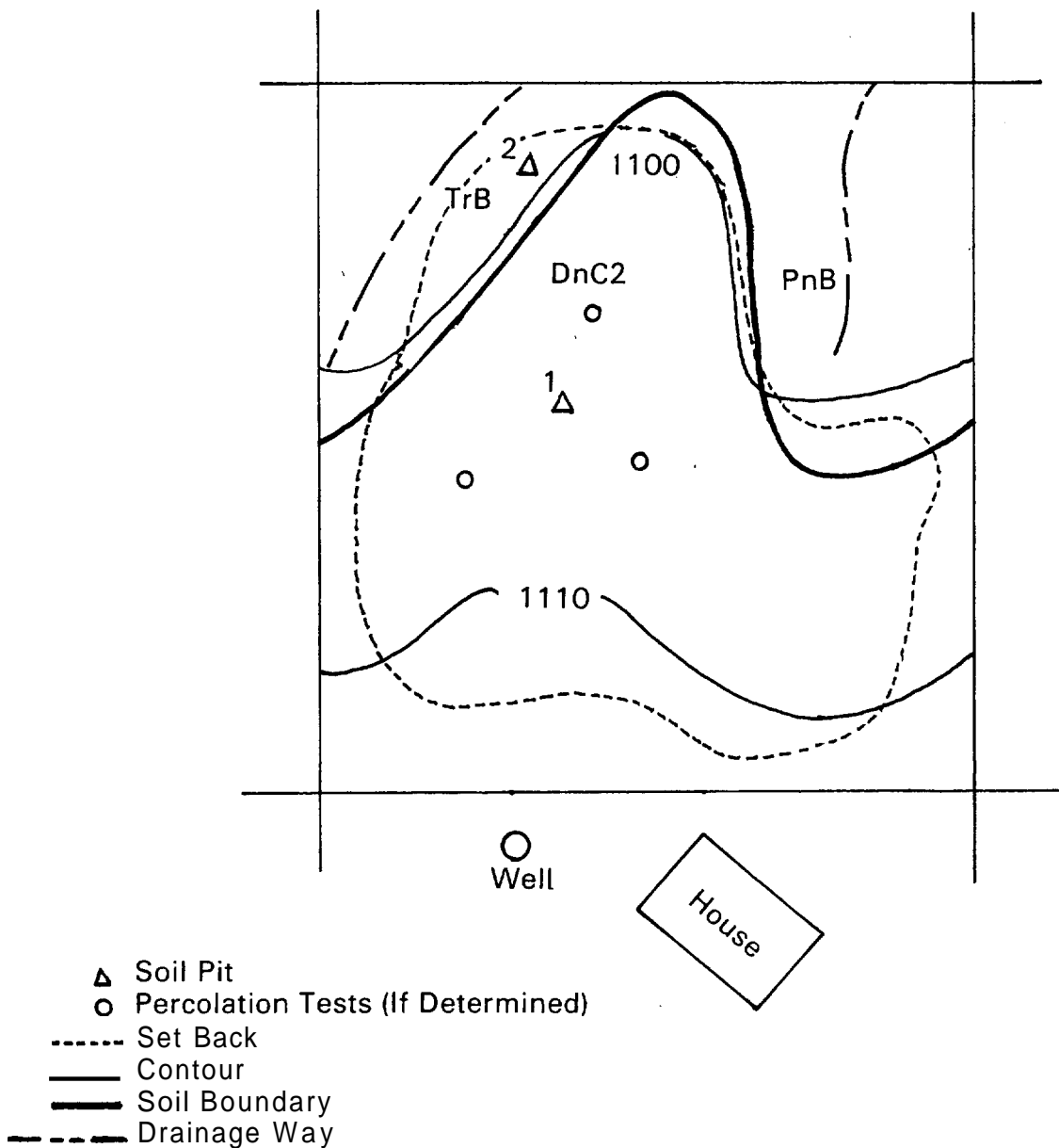

FIGURE 3-16 (continued)

Name: Resident
 Soil Pit No. 1

Depth (Ft.)	Texture	Structure	Color	Soil Saturation
0	Silt Loam	Granular	Brown	None
	Silty Clay Loam	Platy		
2	Clay Loam	Blocky		
4	Sandy Loam	Platy		
6	↓	Massive		
8				
10				
12				
14				

Soil Map Unit - DnC2
 Slope - 6%
 Landscape Position - Side Slope
 Landscape Type - Plane to Concave

FIGURE 3-16 (continued)

Name: Resident

Soil Pit No. 2

	Texture	Structure	Color	Soil Saturation
0	Silt Loam	Blocky	Brown	
2		Granular	Black	
4	Silty Clay Loam	Blocky	Brown	
6	Silt Loam		Massive	
8				Seasonal Saturation
10				
12				
14				

Soil Map Unit - TrB

Slope - 4%

Landscape Position - Footslope

Landscape Type - Concave

3.4 References

1. Small Scale Waste Management Project, University of Wisconsin, Madison. Management of Small Waste Flows. EPA 600/2-78/173 NTIS Report No. PB 286 560, September 1978. 804 pp.
2. Tyler, E. J., R. Laak, E. McCoy, and S.S. Sandhu. The Soil as a Treatment System. In: Proceedings of the Second National Home Sewage Treatment Symposium Chicago, Illinois, December 1977. American Society of Agricultural Engineers, St. Joseph, Michigan, 1978. pp. 22-37.
3. Hillel, D. I. Soil and Water: Physical Principles and Processes. Academic Press, New York, 1971. 302 pp.
4. Flach, K.W. Land Resources. In: Recycling Municipal Sludges and Effluents on Land. Champaign University of Illinois, July 1973.
5. Bennett, E. R., and K. D. Linstedt. Sewage Disposal by Evaporation Transpiration. EPA 600/2-78/163, NTIS Report No. PB 288 588, September 1978. 196 pp.
6. Pickett, E. M. Evapotranspiration and Individual Lagoons. In: Proceedings of Northwest Onsite Wastewater Disposal Short Course, University of Washington, Seattle, December 1976. pp. 108-118.
7. Pruitt W. O. Empirical Method for Estimating Evapotranspiration Using Primarily Evaporation Pans. In: Evapotranspiration and Its Role in Water Resources Management; Conference Proceedings, American Society of Agricultural Engineers, St. Joseph, Michigan, 1966. pp. 57-61.
8. Beck, A. F. Evapotranspiration Pond Design. Environ. Eng. Div., Am. Soc. Civil Eng., 105 411-415, 1979.
9. Bernhart, A. P. Treatment and Disposal of Wastewater From Homes by Soil Infiltration and Evapotranspiration. 2nd ed. University of Toronto Press, Toronto, Canada, 1973.
10. Soil Conservation Service. Soil Survey Manual. USDA Handbook 18, U.S. Government Printing Office, Washington, D.C., 1951. 503 pp.
11. Studies on Household Sewage Disposal Systems. Environmental Health Center, Cincinnati, Ohio, 1949-3 pts.
12. Bouma, J. Evaluation of the Field Percolation Test and an Alternative Procedure to Test Soil Potential for Disposal of Septic Tank Effluent. Soil Sci. Soc. Amer. Proc. 35:871-875, 1971.

13. Winneberger, J. T. Correlation of Three Techniques for Determining Soil permeability. *Environ. Health*, 37:108-118, 1974.
14. Healy, K. A., and R. Laak. Factors Affecting the Percolation Test. *J. Water Pollut. Control Fed.*, 45:1508-1516 1973.
15. Bouma, J. Unsaturated Flow During Soil Treatment of Septic Tank Effluent. *J. Environ. Eng., Am. Soc. Civil Eng.*, 101:967-983 1975.
16. Onsite Wastewater Management. National Environmental Health Association, Denver, Colorado, 1979.
17. Machmeier, R. E. How to Run a Percolation Test. Extension Folder 261, University of Minnesota, St. Paul, 1977.
18. Penman, H. L. Estimating Evaporation. *Trans. Amer. Geophys. Union*, 37:43-46, 1956.

CHAPTER 4

WASTEWATER CHARACTERISTICS

4.1 Introduction

The effective management of any wastewater flow requires a reasonably accurate knowledge of its characteristics. This is particularly true for wastewater flows from rural residential dwellings, commercial establishments and other facilities where individual water-using activities create an intermittent flow of wastewater that can vary widely in volume and degree of pollution. Detailed characterization data regarding these flows are necessary not only to facilitate the effective design of wastewater treatment and disposal systems, but also to enable the development and application of water conservation and waste load reduction strategies.

For existing developments, characterization of the actual wastewaters to be encountered may often times be accomplished. However, for many existing developments, and for almost any new development, wastewater characteristics must be predicted. The purpose of this chapter is to provide a basis for characterizing the wastewater from rural developments. A detailed discussion of the characteristics of residential wastewaters is presented first, followed by a limited discussion of the characteristics of the wastewaters generated by nonresidential establishments, including those of a commercial, institutional and recreational nature. Finally, a general procedure for predicting wastewater characteristics for a given residential dwelling or nonresidential establishment is given.

4.2 Residential Wastewater Characteristics

Residential dwellings exist in a variety of forms, including single- and multi-family households, condominium homes, apartment houses and cottages or resort residences. In all cases, occupancy can occur on a seasonal or year-round basis. The wastewater discharged from these dwellings is comprised of a number of individual wastewaters, generated through water-using activities employing a variety of plumbing fixtures and appliances. The characteristics of the wastewater can be influenced by several factors. Primary influences are the characteristics of the plumbing fixtures and appliances present as well as their frequency of use. Additionally, the characteristics of the residing family in terms of number of family members, age levels, and mobility are important as

is the overall socioeconomic status of the family. The characteristics of the dwelling itself, including seasonal or yearly occupancy, geographic location, and method of water supply and wastewater disposal, appear as additional, but lesser, influences.

4.2.1 Wastewater Flow

4.2.1.1 Average Daily Flow

The average daily wastewater flow from a typical residential dwelling is approximately 45 gal/capita/day (gpcd) (170 liters/capita/day [lpcd]) (Table 4-1). While the average daily flow experienced at one residence compared to that of another can vary considerably, it is typically no greater than 60 gpcd (227 lpcd) and seldom exceeds 75 gpcd (284 lpcd) (Figure 4-1).

4.2.1.2 Individual Activity Flows

The individual wastewater generating activities within a residence are the building blocks that serve to produce the total residential wastewater discharge. The average characteristics of several major residential water-using activities are presented in Table 4-2. A water-using activity that falls under the category of miscellaneous in this table, but deserves additional comment, is water-softener backwash/regeneration flows. Water softener regeneration typically occurs once or twice a week, discharging about 30-88 gal (114 to 333 l) per regeneration cycle (11). On a daily per capita basis, water softener flows have been shown to average about 5 gpcd (19 lpcd), ranging from 2.3 to 15.7 gpcd (8.7 to 59.4 lpcd) (7).

4.2.1.3 Wastewater Flow Variations

The intermittent occurrence of individual wastewater-generating activities creates large variations in the wastewater flow rate from a residence.

a. Minimum and Maximum Daily Flows

The daily wastewater flow from a specific residential dwelling is typically within 10% and 300% of the average daily flow at that dwelling, with the vast majority within 50 and 150% of the average day. At the

TABLE 4-1

SUMMARY OF AVERAGE DAILY RESIDENTIAL WASTEWATER FLOWS

<u>Study</u>	<u>No. of Residences</u>	<u>Duration of Study months</u>	<u>Wastewater Flow</u>	
			<u>Study Average gpcd</u>	<u>Range of Individual Residence Averages gpcd</u>
Linaweaver, et al. (1)	22	-	49	36-66
Anderson and Watson (2)	18	4	44	18-69
Watson, et al. (3)	3	2-12	53	25-65
Cohen and Wallman (4)	8	6	52	37.8-101.6
Laak (5)	5	24	41.4	26.3-65.4
Bennett and Linstedt (6)	5	0.5	44.5	31.8-82.5
Siegrist, et al. (7)	11	1	42.6	25.4-56.9
Otis (8)	21	12	36	8-71
Duffy, et al. (9)	16	12	<u>42.3</u>	-
Weighted Average			44	

FIGURE 4-1

FREQUENCY DISTRIBUTION FOR AVERAGE DAILY
RESIDENTIAL WATER USE/WASTE FLOWS

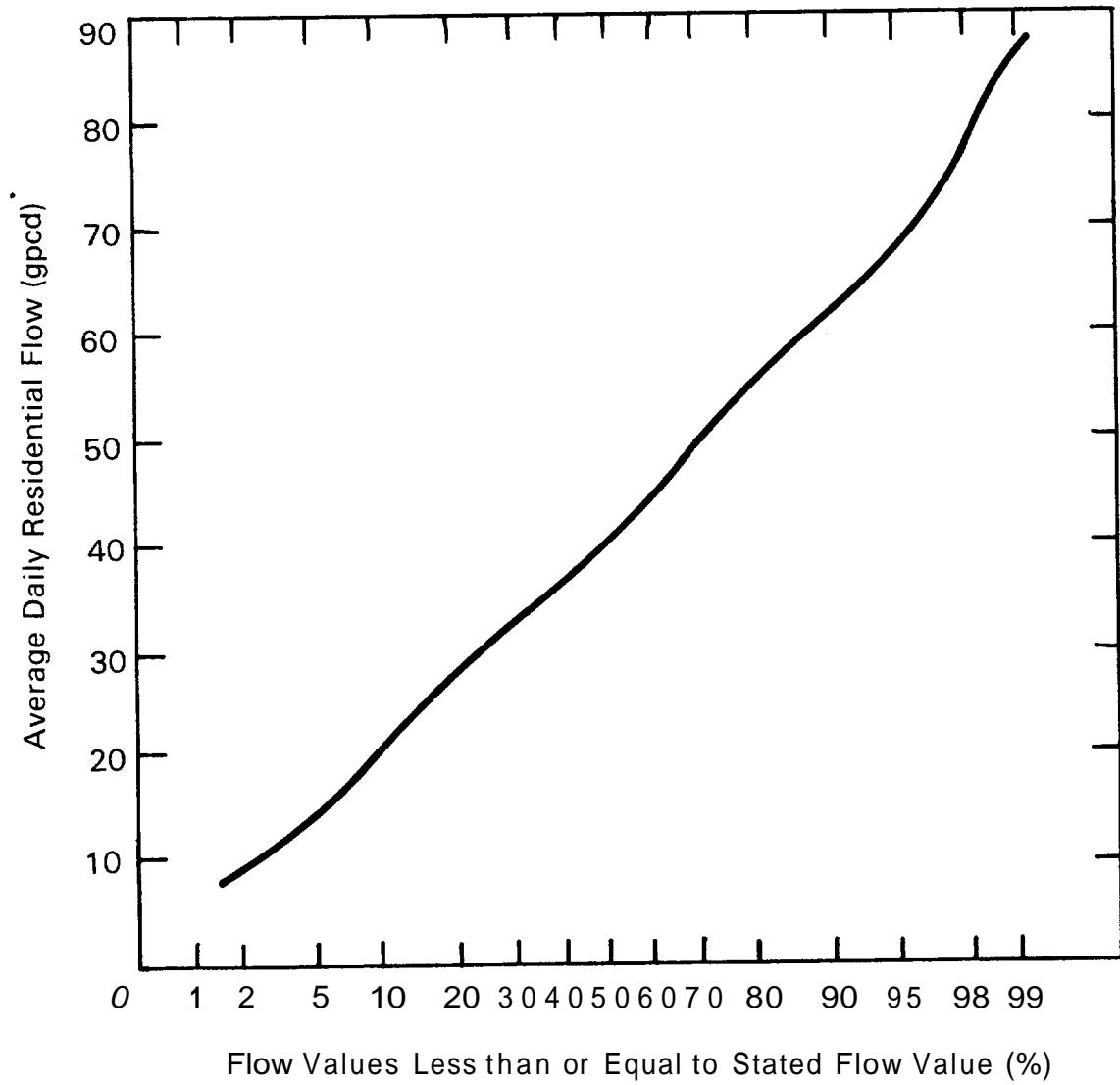

Note: Based on the average daily flow measured for each of the 71 residences studied in (2) (3) (4) (5) (6) (7) (8)

TABLE 4-2
RESIDENTIAL WATER USE BY ACTIVITY^a

<u>Activity</u>	<u>Gal/use</u>	<u>Uses/cap/day</u>	<u>gpcd^b</u>
Toilet Flush	4.3 4.0-5.0	3.5 2.3-4.1	16.2 9.2-20.0
Bathing	24.5 21.4-27.2	0.43 0.32-0.50	9.2 6.3-12.5
Clotheswashing	37.4 33.5-40.0	0.29 0.25-0.31	10.0 7.4-11.6
Dishwashing	8.8 7.0-12.5	0.35 0.15-0.50	3.2 1.1-4.9
Garbage Grinding	2.0 2.0-2.1	0.58 0.4-0.75	1.2 0.8-1.5
Miscellaneous	-	-	6.6 5.7-8.0
Total	-	-	45.6 41.4-52.0

^a Mean and ranges of results reported in (4)(5)(6)(7)(10).

^b gpcd may not equal gal/use multiplied by uses/cap/day due to difference in the number of study averages used to compute the mean and ranges shown.

extreme, however, minimum and maximum daily flows of 0% and 900% of the average daily flow may be encountered (2)(3)(12).

b. Minimum and Maximum Hourly Flows

Minimum hourly flows of zero are typical. Maximum hourly flows are more difficult to quantify accurately. Based on typical fixture and appliance usage characteristics, as well as an analysis of residential water usage demands, maximum hourly flows of 100 gal/hr (380 l/hr) can occur (2)(13). Hourly flows in excess of this can occur due to plumbing fixture and appliance misuse or malfunction (e.g., faucet left on or worn toilet tank flapper).

c. Instantaneous Peak Flows

The peak flow rate from a residential dwelling is a function of the characteristics of the fixtures and appliances present and their position in the overall plumbing system layout. The peak discharge rate from a given fixture/appliance is typically around 5 gal/minute (gpm) (0.3 liters/sec), with the exception of the tank-type water closet which discharges at a peak flow of up to 25 gpm (1.6 l/sec). The use of several fixtures/appliances simultaneously can increase the total flow rate from the isolated fixtures/appliances. However, attenuation occurring in the residential drainage network tends to decrease the peak flow rates in the sewer exiting the residence.

Although field data are limited, peak discharge rates from a single-family dwelling of 5 to 10 gpm (0.3 to 0.6 l/sec) can be expected. For multi-family units, peak rates in excess of these values commonly occur. A crude estimate of the peak flow in these cases can be obtained using the fixture-unit method described in Section 4.3.1.2.

4.2.2 Wastewater Quality

4.2.2.1 Average Daily Flow

The characteristics of typical residential wastewater are outlined in Table 4-3, including daily mass loadings and pollutant concentrations. The wastewater characterized is typical of residential dwellings equipped with standard water-using fixtures and appliances (excluding garbage disposals) that collectively generate approximately 45 gpcd (170 lpcd).

TABLE 4-3
CHARACTERISTICS OF TYPICAL RESIDENTIAL WASTEWATER^a

<u>Parameter</u>	<u>Mass Loading</u> gm/cap/day	<u>Concentration</u> mg/l
Total Solids	115 - 170	680 - 1000
Volatile Solids	65 - 85	380 - 500
Suspended Solids	35 - 50	200 - 290
Volatile Suspended Solids	25 - 40	150 - 240
BOD ₅	35 - 50	200 - 290
Chemical Oxygen Demand	115 - 125	680 - 730
Total Nitrogen	6 - 17	35 - 100
Ammonia	1 - 3	6 - 18
Nitrites and Nitrates	<1	<1
Total Phosphorus	3 - 5	18 - 29
Phosphate	1 - 4	6 - 24
Total Coliforms ^b	-	10 ¹⁰ - 10 ¹²
Fecal Coliforms ^b	-	10 ⁸ - 10 ¹⁰

a For typical residential dwellings equipped with standard water-using fixtures and appliances (excluding garbage disposals) generating approximately 45 gpcd (170 lpcd). Based on the results presented in (5)(6)(7)(10)(13).

b Concentrations presented in organisms per liter.

4.2.2.2 Individual Activity Contributions

Residential water-using activities contribute varying amounts of pollutants to the total wastewater flow. The individual activities may be grouped into three major wastewater fractions: (1) garbage disposal wastes, (2) toilet wastes, and (3) sink, basin, and appliance wastewaters. A summary of the average contribution of several key pollutants in each of these three fractions is presented in Tables 4-4 and 4-5.

With regard to the microbiological characteristics of the individual waste fractions, studies have demonstrated that the wastewater from sinks, basins, and appliances can contain significant concentrations of indicator organisms as total and fecal coliforms (14) (15) (16) (17). Traditionally, high concentrations of these organisms have been used to assess the contamination of a water or wastewater by pathogenic organisms. One assumes, therefore, that these wastewaters possess some potential for harboring pathogens.

4.2.2.3 Wastewater Quality Variations

Since individual water-using activities occur intermittently and contribute varying quantities of pollutants, the strength of the wastewater generated from a residence fluctuates with time. Accurate quantification of these fluctuations is impossible. An estimate of the type of fluctuations possible can be derived from the pollutant concentration information presented in Table 4-5 considering that the activities included occur intermittently.

4.3 Nonresidential Wastewater Characteristics

The rural population, as well as the transient population moving through the rural areas, is served by a wide variety of isolated commercial establishments and facilities. For many establishments, the wastewater-generating sources are sufficiently similar to those in a residential dwelling that residential wastewater characteristics can be applied. For other establishments, however, the wastewater characteristics can be considerably different from those of a typical residence.

Providing characteristic wastewater loadings for "typical" non-residential establishments is a very complex task due to several factors. First, there is a relatively large number of diverse establishment categories (e.g., bars, restaurants, drive-in theaters, etc.). The inclusion of potentially diverse establishments within the same category produces a potential for large variations in waste-generating sources

TABLE 4-4

POLLUTANT CONTRIBUTIONS OF MAJOR RESIDENTIAL
WASTEWATER FRACTIONS^a (gm/cap/day)

<u>Parameter</u>	<u>Garbage Disposal</u>	<u>Toilet</u>	<u>Basins, Sinks, Appliances</u>	<u>Approximate Total</u>
BOD ₅	18.0 10.9-30.9	16.7 6.9-23.6	28.5 24.5-38.8	63.2
Suspended Solids	26.5 15.8-43.6	27.0 12.5-36.5	17.2 10.8-22.6	70.7
Nitrogen	0.6 0.2-0.9	8.7 4.1-16.8	1.9 1.1-2.0	11.2
Phosphorus	0.1 0.1-0.1	1.2 0.6-1.6	2.8 2.2-3.4	4.0

a Means and ranges of results reported in (5) (6) (7) (10) (14)

TABLE 4-5

POLLUTANT CONCENTRATIONS OF MAJOR RESIDENTIAL
WASTEWATER FRACTIONS^a (mg/l)

<u>Parameter</u>	<u>Garbage Disposal</u>	<u>Toilet</u>	<u>Basins, Sinks, Appliances</u>	<u>Combined Wastewater</u>
BOD ₅	2380	280	260	360
Suspended Solids	3500	450	160	400
Nitrogen	79	140	17	63
Phosphorus	13	20	26	23

a Based on the average results presented in Table 4-4 and the following wastewater flows: Garbage disposal - 2 gpcd (8 lpcd); toilet - 16 gpcd (61 lpcd); basins, sinks and appliances - 29 gpcd (110 lpcd); total - 47 gpcd (178 lpcd).

and the resultant wastewater characteristics. Further, many intangible influences such as location, popularity, and price may produce substantial wastewater variations between otherwise similar establishments. Finally, there is considerable difficulty in presenting characterization data in units of measurement that are easy to apply, yet predictively accurate. (For example, at a restaurant, wastewater flow in gal/seat is easy to apply to estimate total flow, but is less accurate than if gal/meal served were used.)

In this section, limited characterization data for nonresidential establishments, including commercial establishments, institutional facilities, and recreational areas, are presented. These data are meant to serve only as a guide, and as such should be applied cautiously. Whenever possible, characterization data for the particular establishment in question, or a similar one in the vicinity, should be obtained.

4.3.1 Wastewater Flow

4.3.1.1 Average Daily Flow

Typical daily flows from a variety of commercial, institutional, and recreational establishments are presented in Tables 4-6 to 4-8.

4.3.1.2 Wastewater Flow Variation

The wastewater flows from nonresidential establishments are subject to wide fluctuations with time. While difficult to quantify accurately, an estimate of the magnitude of the fluctuations, including minimum and maximum flows on an hourly and daily basis, can be made if consideration is given to the characteristics of the water-using fixtures and appliances, and to the operational characteristics of the establishment (hours of operation, patronage fluctuations, etc.).

Peak wastewater flows can be estimated utilizing the fixture-unit method (19)(20). As originally developed, this method was based on the premise that under normal usage, a given type of fixture had an average flow rate and duration of use (21)(22). One fixture unit was arbitrarily set equal to a flow rate of 7.5 gpm (0.51/sec), and various fixtures were assigned a certain number of fixture units based upon their particular characteristics (Table 4-9). Based on probability studies, relationships were developed between peak water use and the total number of fixture units present (Figure 4-2).

TABLE 4-6

TYPICAL WASTEWATER FLOWS FROM COMMERCIAL SOURCES (18)

<u>Source</u>	<u>Unit</u>	<u>Wastewater Flow</u>	
		<u>Range</u>	<u>Typical</u> gpd/unit
Airport	Passenger	2.1 - 4.0	2.6
Automobile Service Station	Vehicle Served	7.9 - 13.2	10.6
	Employee	9.2 - 15.8	13.2
Bar	Customer	1.3 - 5.3	2.1
	Employee	10.6 - 15.8	13.2
Hotel	Guest	39.6 - 58.0	50.1
	Employee	7.9 - 13.2	10.6
Industrial Building (excluding industry and cafeteria)	Employee	7.9 - 17.2	14.5
Laundry (self-service)	Machine	475 - 686	580
	Wash	47.5 - 52.8	50.1
Motel	Person	23.8 - 39.6	31.7
Motel with Kitchen	Person	50.2 - 58.1	52.8
Office	Employee	7.9 - 17.2	14.5
Restaurant	Meal	2.1 - 4.0	2.6
Rooming House	Resident	23.8 - 50.1	39.6
Store, Department	Toilet room	423 - 634	528
	Employee	7.9 - 13.2	10.6
Shopping Center	Parking Space	0.5 - 2.1	1.1
	Employee	7.9 - 13.2	10.6

TABLE 4-7

TYPICAL WASTEWATER FLOWS FROM INSTITUTIONAL SOURCES (18)

<u>Source</u>	<u>Unit</u>	<u>Wastewater Flow</u>	
		<u>Range</u>	<u>Typical</u>
		gpd/unit	
Hospital, Medical	Bed	132 - 251	172
	Employee	5.3 - 15.9	10.6
Hospital, Mental	Bed	79.3 - 172	106
	Employee	5.3 - 15.9	10.6
Prison	Inmate	79.3 - 159	119
	Employee	5.3 - 15.9	10.6
Rest Home	Resident	52.8 - 119	92.5
	Employee	5.3 - 15.9	10.6
School, Day: With Cafeteria, Gym, Showers	Student	15.9 - 30.4	21.1
	Student	10.6 - 21.1	15.9
	Student	5.3 - 17.2	10.6
School, Boarding	Student	52.8 - 106	74.0

TABLE 4-8

TYPICAL WASTEWATER FLOWS FROM RECREATIONAL SOURCES (18)

<u>Source</u>	<u>Unit</u>	<u>Wastewater Flow</u>	
		<u>Range</u>	<u>Typical</u>
		gpd/unit	
Apartment, Resort	Person	52.8 - 74	58.1
Cabin, Resort	Person	34.3 - 50.2	42.3
Cafeteria	Customer	1.1 - 2.6	1.6
	Employee	7.9 - 13.2	10.6
Campground (developed)	Person	21.1 - 39.6	31.7
Cocktail Lounge	Seat	13.2 - 26.4	19.8
Coffee Shop	Customer	4.0 - 7.9	5.3
	Employee	7.9 - 13.2	10.6
Country Club	Member Present	66.0 - 132	106
	Employee	10.6 - 15.9	13.2
Day Camp (no meals)	Person	10.6 - 15.9	13.2
Dining Hall	Meal Served	4.0 - 13.2	7.9
Dormitory, Bunkhouse	Person	19.8 - 46.2	39.6
Hotel, resort	Person	39.6 - 63.4	52.8
Laundromat	Machine	476 - 687	581
Store Resort	Customer	1.3 - 5.3	2.6
	Employee	7.9 - 13.2	10.6
Swimming Pool	Customer	5.3 - 13.2	10.6
	Employee	7.9 - 13.2	10.6
Theater	Seat	2.6 - 4.0	2.6
Visitor Center	Visitor	4.0 - 7.9	5.3

TABLE 4-9

FIXTURE-UNITS PER FIXTURE (19)

<u>Fixture Type</u>	<u>Fixture-Units</u>
One bathroom group consisting of tank-operated water closet, lavatory, and bathtub or shower stall	6
Bathtub (with or without overhead shower)	2
Bidet	3
Combination sink-and-tray	3
Combination sink-and-tray with food-disposal unit	4
Dental unit or cuspidor	1
Dental lavatory	1
Drinking fountain	1/2
Dishwasher, domestic	2
Floor drains	1
Kitchen sink, domestic	2
Kitchen sink, domestic, with food waste grinder	3
Lavatory	1
Lavatory	2
Lavatory, barber, beauty parlor	2
Lavatory, surgeon's	2
Laundry tray (1 or 2 compartments)	2
Shower stall, domestic	2
Showers (group) per head	3
Sinks	
Surgeon's	3
Flushing rim (with valve)	8
Service (trap standard)	3
Service (P trap)	2
Pot, scullery, etc.	4
Urinal, pedestal, syphon jet, blowout	8
Urinal, wall lip	4
Urinal stall, washout	4
Urinal trough (each 2-ft section)	2
Wash sink (circular or multiple) each set of faucets	2
Water closet, tank-operated	4
Water closet, valve-operated	8

FIGURE 4-2

PEAK DISCHARGE VERSUS FIXTURE UNITS PRESENT (22)

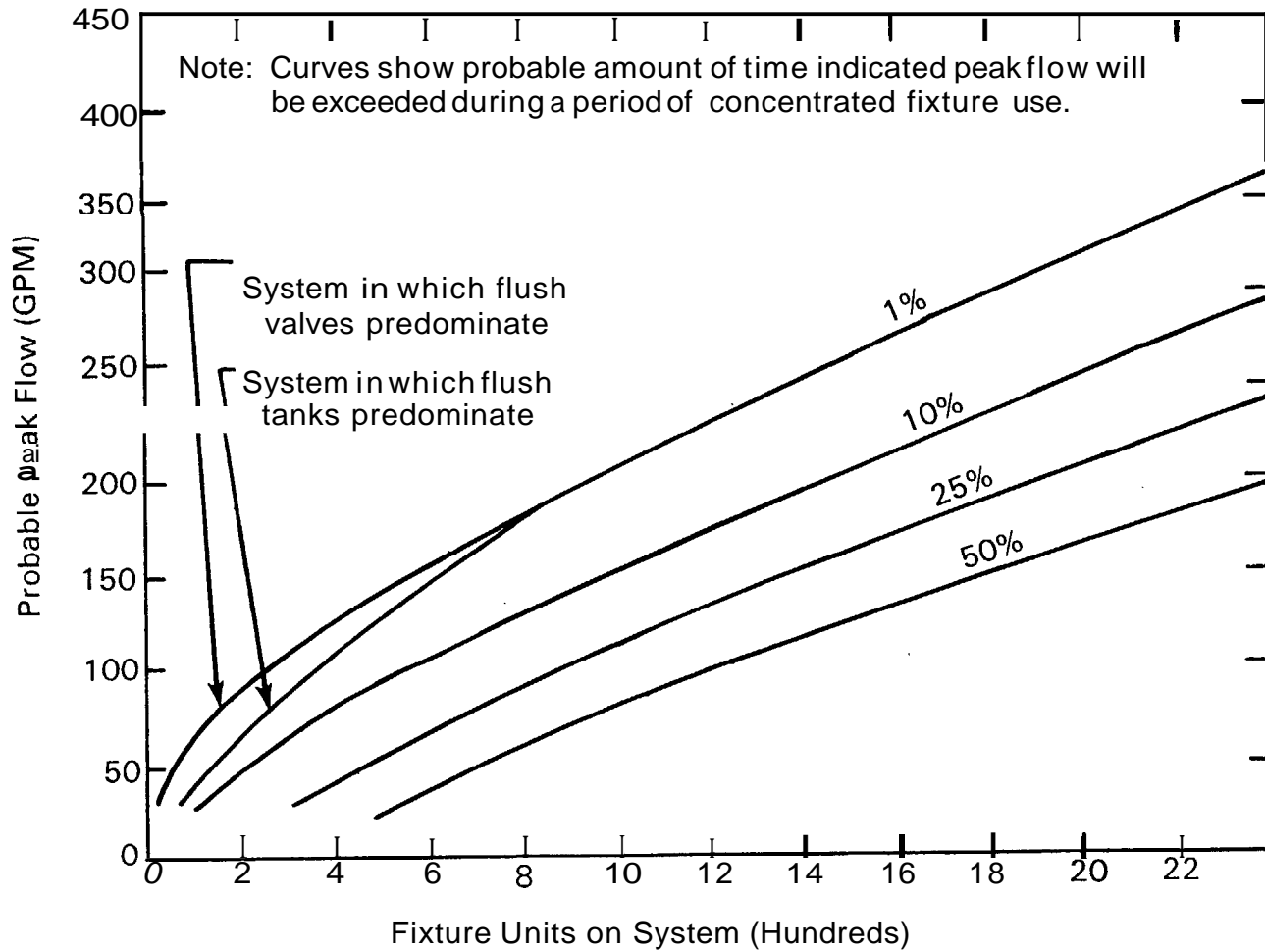

4.3.2 Wastewater Quality

The qualitative characteristics of the wastewaters generated by non-residential establishments can vary significantly between different types of establishments due to the extreme variation which can exist in the waste generating sources present. Consideration of the waste-generating sources present at a particular establishment can give a general idea of the character of the wastewater, and serve to indicate if the wastewater will contain any problem constituents, such as high grease levels from a restaurant or lint fibers in a laundromat wastewater.

If the waste-generating sources present at a particular establishment are similar to those typical of a residential dwelling, an approximation of the pollutant mass loadings and concentrations of the wastewater produced may be derived using the residential wastewater quality data presented in Tables 4-3 to 4-5. For establishments where the waste-generating sources appear significantly different from those in a residential dwelling, or where more refined characterization data are desired, a detailed review of the pertinent literature, as well as actual wastewater sampling at the particular or a similar establishment, should be conducted.

4.4 Predicting Wastewater Characteristics

4.4.1 General Considerations

4.4.1.1 Parameter Design Units

In characterizing wastewaters, quantitative and qualitative characteristics are often expressed in terms of other parameters. These parameter design units, as they may be called, vary considerably depending on the type of establishment considered. For residential dwellings, daily flow values and pollutant contributions are expressed on a per person (capita) basis. Applying per capita data to predict total residential wastewater characteristics requires that a second parameter be considered, namely, the number of persons residing in the residence. Residential occupancy typically ranges from 1.0 to 1.5 persons per bedroom. Although it provides for a conservative estimate, the current practice is to assume that maximum occupancy is two persons per bedroom.

For nonresidential establishments, wastewater characteristics are expressed in terms of a variety of units. Although per capita units are employed, a physical characteristic of the establishment, such as per seat, per car stall, or per square foot, is more commonly used.

4.4.1.2 Factors of Safety

To account for the potential variability in the wastewater characteristics at a particular dwelling or establishment, versus that of the average, conservative predictions or factors of safety are typically utilized. These factors of safety can be applied indirectly, through choice of the design wastewater characteristics and the occupancy patterns, as well as directly through an overall factor. For example, if an average daily flow of 75 gpcd (284 lpcd) and an occupancy of two persons per bedroom were selected, the flow prediction for a three-bedroom home would include a factor of safety of approximately 3 when compared to average conditions (i.e., 45 gpcd [170 lpcd] and 1 person per bedroom). If a direct factor of safety were also applied (e.g., 1.25), the total factor of safety would increase to approximately 3.75.

Great care must be exercised in predicting wastewater characteristics so as not to accumulate multiple factors of safety which would yield an extremely overconservative estimate.

4.4.2 Strategy for Predicting Wastewater Characteristics

Predicting wastewater characteristics from rural developments can be a complex task. Following a logical step-by-step procedure can help simplify the characterization process and render the estimated wastewater characteristics more accurate. A flow chart detailing a procedure for predicting wastewater characteristics is presented in Figure 4-3.

FIGURE 4-3

STRATEGY FOR PREDICTING WASTEWATER CHARACTERISTICS

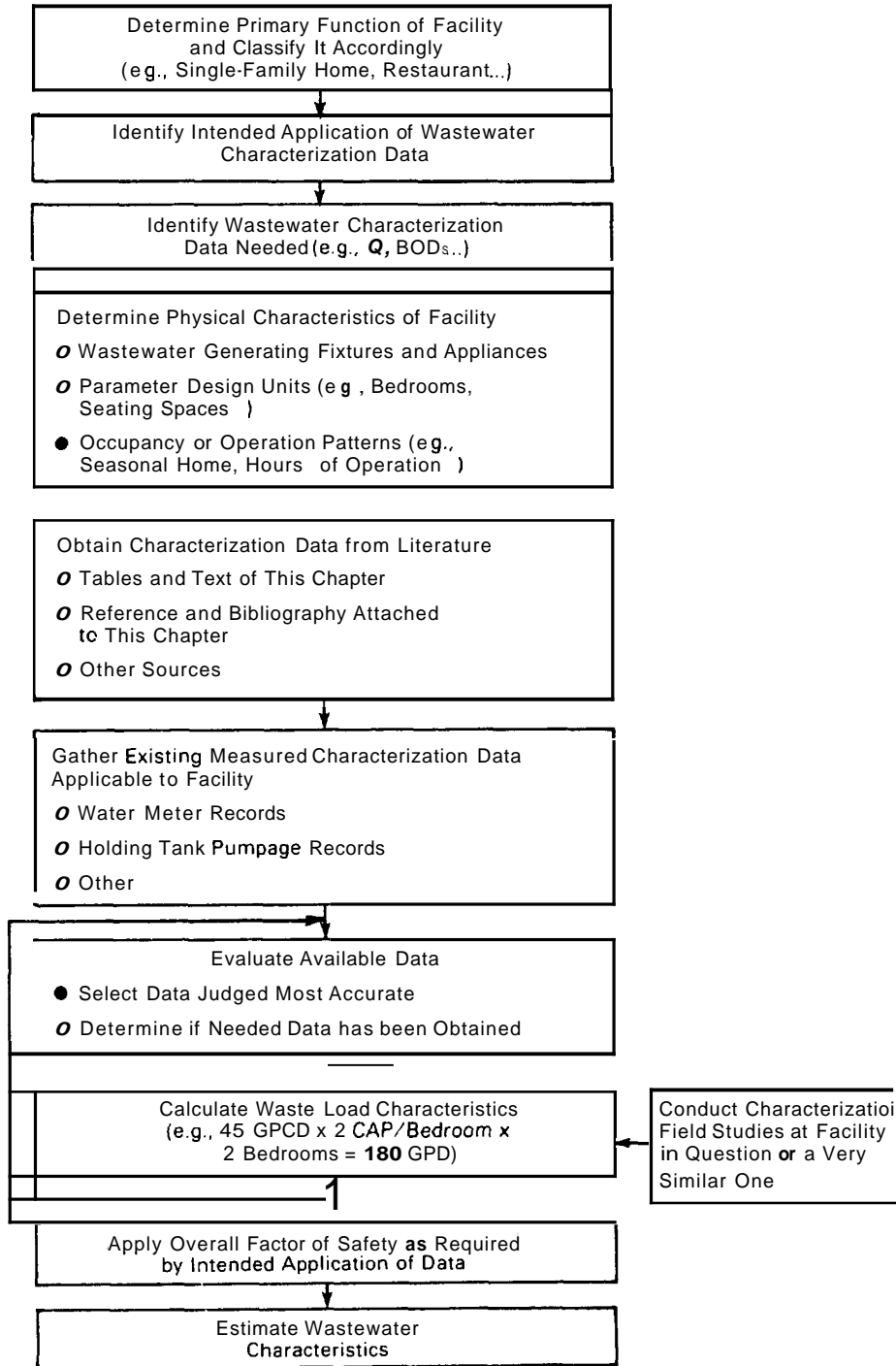

4.5 References

1. Linaweaver, F. P., Jr., J. C. Geyer, and J. B. Wolff. A Study of Residential Water Use. Department of Environmental Studies, Johns Hopkins University, Baltimore, Maryland, 1967. 105 pp.
2. Anderson, J. S., and K. S. Watson. Patterns of Household Usage. J. Am. Water Works Assoc., 59:1228-1237, 1967.
3. Watson, K. S., R. P. Farrell, and J. S. Anderson. The Contribution from the Individual Home to the Sewer System. J. Water Pollut. Control Fed., 39:2039-2054, 1967.
4. Cohen, S., and H. Wallman. Demonstration Of Waste Flow Reduction From Households. EPA 670/2-74-071, NTIS Report No. PB 236 904, 1974. 111 pp.
5. Laak, R. Relative Pollution Strengths of Undiluted Waste Materials Discharged in Households and the Dilution Waters Used for Each. Manual of Grey Water Treatment Practice - Part II, Monogram Industries, Inc., Santa Monica, California, 1975.
6. Bennett, E. R., and E. K. Linstedt. Individual Home Wastewater Characterization and Treatment. Completion Report Series No. 66, Environmental Resources Center, Colorado State University, Fort Collins, 1975. 145 pp.
7. Siegrist, R. L., M. Witt, and W. C. Boyle. Characteristics of Rural Household Wastewater. J. Env. Eng. Div., Am. Soc. Civil Eng., 102:553-548, 1976.
8. Otis, R. J. An Alternative Public Wastewater Facility for a Small Rural Community. Small Scale Waste Management Project, University of Wisconsin, Madison, 1978.
9. Duffy, C. P., et al. Technical Performance of the Wisconsin Mound System for On-Site Wastewater Disposal - An Interim Evaluation. Presented in Preliminary Environmental Report for Three Alternative Systems (Mounds) for On-site Individual Wastewater Disposal in Wisconsin. Wisconsin Department of Health and Social Services, December 1978.
10. Ligman, K., N. Hutzler, and W. C. Boyle. Household Wastewater Characterization. J. Environ. Eng. Div., Am. Soc. Civil Eng., 150:201-213, 1974.
11. Weickart, R. F. Effects of Backwash Water and Regeneration Wastes From Household Water Conditioning Equipment on Private Sewage Disposal Systems. Water Quality Association, Lombard, Illinois, 1976.

12. Witt, M. Water Use in Rural Homes. MS. study. University of Wisconsin-Madison, 1974.
13. Jones, E. E., Jr. Domestic Water Use in Individual Homes and Hydraulic Loading of and Discharge from Septic Tanks. In: Proceedings of the National Home Sewage Disposal Symposium, Chicago, December 1974. American Society of Agricultural Engineers, St. Joseph, Michigan. pp. 89-103.
14. Olsson, E., L. Karlgren, and V. Tullander. Household Wastewater. National Swedish Institute for Building Research, Stockholm, Sweden, 1968.
15. Hypes, W. D., C. E. Batten, and J. R. Wilkins. The Chemical/Physical and Microbiological Characteristics of Typical Bath and Laundry Wastewaters. NASA TN D-7566, Langley Research Center, Langley Station, Virginia, 1974. 31 pp.
16. Small Scale Waste Management Project, University of Wisconsin, Madison. Management of Small Waste Flows. EPA 600/2-78-173, NTIS Report No. PB 286 560, September 1978. 804 pp.
17. Brandes, M. Characteristics of Effluents From Separate Septic Tanks Treating Grey and Black Waters From the Same House. J. Water Pollut. Control Fed., 50:2547-2559, 1978.
18. Metcalf and Eddy, Inc. Wastewater Engineering: Treatment/Disposal/Reuse. 2nd ed. McGraw-Hill, New York, 1979. 938 pp.
19. Design and Construction of Sanitary and Storm Sewers. Manual of Practice No. 9. Water Pollution Control Federation, Washington, D.C., 1976. 369 pp.
20. Uniform Plumbing Code. International Association of Plumbing and Mechanical Officials, Los Angeles, California, 1976.
21. Hunter, R. B. Method of Estimating Loads in Plumbing Systems. Building Materials and Structures Report BMS65, National Bureau of Standards, Washington, D.C., 1940. 23 pp.
22. Hunter, R. B. Water Distribution Systems for Buildings, Building Materials and Structures Report BMS79, National Bureau of Standards, Washington, D.C., 1941.

CHAPTER 5

WASTEWATER MODIFICATION

5.1 Introduction

The characteristics of the influent wastewater can have a major impact on most any onsite treatment and disposal/reuse system. To enhance conventional strategies, and to encourage new ones, methods can be used to modify the typical characteristics of the influent wastewater.

Methods for wastewater modification have been developed as part of three, basic interrelated strategies: water conservation and wastewater flow reduction, pollutant mass reduction, and onsite containment for offsite disposal. Each strategy attempts to reduce the flow volume or to decrease the mass of key pollutants such as oxygen-demanding substances, suspended solids, nutrients, and pathogenic organisms in the influent wastewater to the onsite disposal system.

Although the primary thrust of this chapter is directed toward residential dwellings, many of the concepts and techniques presented have equal or even greater application to nonresidential establishments. Good practice dictates that water conservation/flow reduction be employed to the maximum extent possible in a dwelling served by an onsite wastewater system.

At the onset, there are several general considerations regarding wastewater modification. First, there are a number of methods available, including a wide variety of devices, fixtures, appliances, and systems. Further, the number of methods and the diversity of their characteristics is ever growing. In many cases, the methods involve equipment manufactured by one or more companies as proprietary products. In this chapter, only generic types of these products are considered. Also, many methods and system components are presently in various stages of development and/or application; therefore, only preliminary or projected operation and performance information may be available. Finally, the characteristics of many of the methods discussed may result in their nonconformance with existing local plumbing codes.

5.2 Water Conservation and Wastewater Flow Reduction

An extensive array of techniques and devices are available to reduce the average water use and concomitant wastewater flows generated by individual water-using activities and, in turn, the total effluent from the residence or establishment. The diversity of present wastewater flow reduction methods is illustrated in Table 5-1. As shown, the methods may be divided into three major groups: (1) elimination of nonfunctional water use, (2) water-saving devices, fixtures, and appliances; and (3) wastewater recycle/reuse systems.

5.2.1 Elimination of Nonfunctional Water Use

Wasteful water use habits can occur with most water-using activities. A few illustrative examples include using a toilet flush to dispose of a cigarette butt, allowing the water to run while brushing teeth or shaving, or operating a clotheswasher or dishwasher with only a partial load. Obviously, the potential for wastewater flow reductions through elimination of these types of wasteful use vary tremendously between homes, from minor to significant reductions, depending on existing habits.

5.2.1.1 Improved Plumbing and Appliance Maintenance

Unseen or apparently insignificant leaks from household fixtures and appliances can waste large volumes of water and generate similar quantities of wastewater. Most notable in this regard are leaking toilets and dripping faucets. For example, a steadily dripping faucet can waste up to several hundred gallons per day.

5.2.1.2 Maintain Nonexcessive Water Supply Pressure

The water flow rate through sink and basin faucets, showerheads, and similar fixtures is highly dependent on the water pressure in the water supply line. For most residential uses, a pressure of 40 psi (2.8 kg/cm²) is adequate. Pressure in excess of this can result in unnecessary water use and wastewater generation. To illustrate, the flow rate through a typical faucet opened fully is about 40% higher at a supply pressure of 80 psi (5.6 kg/cm²) versus that at 40 psi (2.8 kg/cm²).

TABLE 5-1

EXAMPLE WASTEWATER FLOW REDUCTION METHODS

- I. Elimination of Nonfunctional Water Use
 - A. Improved water use habits
 - B. Improved plumbing and appliance maintenance
 - C. Nonexcessive water supply pressure
- II. Water-Saving Devices, Fixtures, and Appliances
 - A. Toilet
 - 1. Water carriage toilets
 - a. Toilet tank inserts
 - b. Dual-flush toilets
 - c. Water-saving toilets
 - d. Very low-volume flush toilets
 - (1) Wash-down flush
 - (2) Mechanically assisted
 - o Pressurized tank
 - o Compressed air
 - o Vacuum
 - o Grinder
 - 2. Non-water carriage toilets
 - a. Pit privies
 - b. Composting toilets
 - c. Incinerator toilets
 - d. Oil-carriage toilets
 - B. Bathing devices, fixtures, and appliance
 - 1. Shower flow controls
 - 2. Reduced-flow showerheads
 - 3. On/Off showerhead valves
 - 4. Mixing valves
 - 5. Air-assisted low-flow shower system
 - C. Clotheswashing devices, fixtures, and appliances
 - 1. Front-loading washer
 - 2. Adjustable cycle settings
 - 3. Washwater recycle feature
 - D. Miscellaneous
 - 1. Faucet inserts
 - 2. Faucet aerators
 - 3. Reduced-flow faucet fixtures
 - 4. Mixing valves
 - 5. Hot water pipe insulation
 - 6. Pressure-reducing valves
- III. Wastewater Recycle/Reuse Systems
 - A. Bath/Laundry wastewater recycle for toilet flushing
 - B. Toilet wastewater recycle for toilet flushing
 - C. Combined wastewater recycle for toilet flushing
 - D. Combined wastewater recycle for several uses

5.2.2 Water-Saving Devices, Fixtures, and Appliances

The quantity of water traditionally used by a given water-using fixture or appliance is often considerably greater than actually needed. Certain tasks may even be accomplished without the use of water. As presented in Table 4-2, over 70% of a typical residential dwelling's wastewater flow volume is collectively generated by toilet flushing, bathing, and clotheswashing. Thus, efforts to accomplish major wastewater flow reductions should be directed toward these three activities.

5.2.2.1 Toilet Devices and Systems

Each flush of a conventional water-carriage toilet uses between 4 and 7 gal (15 and 26 l) of water depending on the model and water supply pressure. On the average, a typical flush generates approximately 4.3 gal (16 l) of wastewater. When coupled with 3.5 uses/cap/day, a daily wastewater flow of approximately 16 gpcd (61 lpcd) results (Table 4-2).

A variety of devices have been developed for use with a conventional flush toilet to reduce the volume of water used in flushing. Additionally, alternatives to the conventional water-carriage toilet are available, certain of which use little or no water to transport human wastewater products. Tables 5-2 and 5-3 present a summary of a variety of toilet devices and systems. Additional details regarding the non-water carriage toilets may be found elsewhere (1)(2)(3)(4)(5).

5.2.2.2 Bathing Devices and Systems

Although great variation exists in the quantity of wastewater generated by a bath or shower, typical values include approximately 25 gal (95 l) per occurrence coupled with a 0.4 use/capita/day frequency to yield a daily per capita flow of about 10 gal (38 l) (Table 4-2). The majority of devices available to reduce bathing wastewater flow volumes are concentrated around the activity of showering, with their objective being to reduce normal 4- to 10-gal/min (0.25 to 0.63 l/sec) showering flow rate. Several flow reduction devices and systems for showering are characterized in Table 5-4. The amount of total wastewater flow reduction accomplished with these devices is highly dependent on individual user habits. Reductions vary from a negative value to as much as 12% of the total wastewater volume.

TABLE 5-2

WASTEWATER FLOW REDUCTION - WATER CARRIAGE TOILETS AND SYSTEMS

Generic Type	Description	Develop- ment Stage ^a	Application Considerations	Operation and Maintenance	Water Use	Total Flow Reduction ^b	
					Per Event gal	gpcd	%
Toilet with Tank Inserts	Displacement devices placed into storage tank of conventional toilets to reduce volume but not height of stored water. Varieties: Plastic bottles, flexible panels, drums or plastic bags.	4-5	Device must be compatible with existing toilet and not interfere with flush mechanism. Installation by owner.	Post-installation and periodic inspections to insure proper positioning.	3.3-3.8	1.8-3.5	4-8
<i>f</i> Dual Flush Toilets	Devices made for use with conventional flush toilets; enable user to select from two or more flush volumes based on solid or liquid waste materials. Varieties: Many	3	Device must be compatible with existing toilet and not interfere with flush mechanism. Installation by owner.	Post-installation and periodic inspections to insure proper positioning and functioning.	2.5-4.3	3.0-7.0	6-15
Water-Saving Toilets	Variation of conventional flush toilet fixture; similar in appearance and operation. Redesigned flushing rim and priming jet to initiate siphon flush in smaller trapway with less water. Varieties: Many manufacturers but units similar.	5	Interchangeable with conventional fixture. Requires pressurized water supply.	Essentially the same as for a conventional unit.	3.0-3.5	2.8-4.6	6-10

TABLE 5-2 (continued)

<u>Generic Type</u>	<u>Description</u>	<u>Develop- ment Stage^a</u>	<u>Application Considerations</u>	<u>Operation and Maintenance</u>	<u>Water Use Per Event gal</u>	<u>Total Flow Reduction^b</u>	
						<u>gpcd</u>	<u>%</u>
Washdown Flush Toilets	Flushing uses only water, but substantially less due to washdown flush. Varieties: Few	3-4	Rough-in for unit may be nonstandard. Drain line slope and lateral run restrictions. Requires pressurized water supply.	Similar to conventional toilet, but more frequent cleaning possible.	0.8-1.6	9.4-12.2	21-27
75 Pressurized Tank	Specially designed toilet tank to pressurize air contained in toilet tank. Upon flushing, the compressed air propels water into bowl at increased velocity. Varieties: Few.	3	Compatible with most any conventional toilet unit. Increased noise level. Water supply pressure of 35 to 120 psi.	Similar to conventional toilet fixture.	2.0-2.5	6.3-8.0	14-18
Compressed Air-Assisted Flush Toilets	Similar in appearance and user operation to conventional toilet; specially designed to utilize compressed air to aid in flushing. Varieties: Few	3-4	Interchangeable with rough-in for conventional fixture. Requires source of compressed air; bottled or air compressor. If air compressor, need power source.	Periodic maintenance of compressed air source. Power use - 0.002 Kwh per use.	0.5	13.3	30

TABLE 5-2 (continued)

<u>Generic Type</u>	<u>Description</u>	<u>Develop- ment Stage^a</u>	<u>Application Considerations</u>	<u>Operati on and Maintenance</u>	<u>Water Use</u>	<u>Total Flow Reduction^b</u>	
					<u>Per Event</u> gal	<u>gpcd</u>	<u>%</u>
Vacuum- Assisted Flush Toilets	Similar in appearance and user operation to conventional toilet; specially designed fixture is connected to vacuum system which assists a small volume of water in flushing. Varieties: Several.	3	Application largely for multi-unit toilet installations Above floor, rear discharge. Drain pipe may be horizontal or inclined. Requires vacuum pump. Requires power source.	Periodic maintenance of vacuum pump. Power use = 0.002 KwH per use.	0.3	14	31

^a 1 = Prototype developed and under evaluation.
 2 = Development complete, commercial production initiated, not locally available.
 3 = Fully developed, limited use, not locally available, mail order purchase likely.
 4 = Fully developed, limited use, locally available from plumbing supply houses or hardware stores.
 5 = Fully developed, widespread use, locally available from plumbing supply houses or hardware stores.

^b Compared to conventional toilet usage (4.3 gal/flush, 3.5 uses/cap/day, and a total daily flow of 45 gpcd).

TABLE 5-3

WASTEWATER FLOW REDUCTION - NON-WATER CARRIAGE TOILETS

<u>Generic Type^a</u>	<u>Description</u>	<u>Development Stage^b</u>	<u>Application Considerations</u>	<u>Operation and Maintenance</u>
Pit Privy	Hand-dug hole in the ground covered with a squatting plate or stool/seat with an enclosing house. May be sealed vault rather than dug hole.	4	Requires same site conditions as for wastewater disposal (see Chapter 8), unless sealed vault. Handles only toilet wastes Outdoor installation. May be constructed by user.	When full, cover with 2 ft of soil and construct new pit.
Composting Privy	Similar to pit privy except organic matter is added after each use. When pit is full it is allowed to compost for a period of about 12 months prior to removal and use as soil amendment.	4	Can be constructed independent of site conditions if sealed vault. Handles only toilet waste and garbage. May be constructed by user. Outdoor installation. Residuals disposal.	Addition of organic matter after each use. Removal and disposal/reuse of composted material.
Composting-Small	Small self-contained units accept toilet wastes only and utilize the addition of heat in combination with aerobic biological activity to stabilize human excreta. Varieties: Several.	3-4	Installation requires 4-in. diameter roof vent. Handles only toilet waste. Set usage capacity. Power required. Residuals disposal.	Removal and disposal of composted material quarterly. Power use = 2.5 KWH/day. Heat loss through vent.
Composting-Large	Larger units with a separated decomposition chamber. Accept toilet wastes and other organic matter, and over a long time period stabilize excreta through biological activity. Varieties: Several	3-4	Installation requires 6- to 12-in. diameter roof vent and space beneath floor for decomposition chamber. Handles toilet waste and some kitchen waste. Set usage capacity. May be difficult to retrofit. Residuals disposal.	Periodic addition of organic matter. Removal of composted material at 6 to 24 month intervals. Power use = 0.3 to 1.2 KWH/day. Heat loss through vent.

TABLE 5-3 (continued)

<u>Generic Type^a</u>	<u>Description</u>	<u>Develop- ment Stage^b</u>	<u>Application Considerations</u>	<u>Operation and Maintenance</u>
Incinerator	Small self-contained units which volatilize the organic components of human waste and evaporate the liquids Varieties: Several.	3	Installation requires 4-in. diameter roof vent. Handles only toilet waste. Power or fuel required. Increased noise level. Residuals disposal.	Weekly removal of ash. Semiannual cleaning and adjustment of burning assembly and/or heating elements. Power use = 1.2 Kwh or 0.3 lb LP gas per use.
Oil Recycle	Systems use a mineral oil to transport human excreta from a fixture (similar in appearance and use to conventional) to a storage tank. Oil is purified and reused for flushing. Varieties: few.	2	Requires separate plumbing for toilet fixture. May be difficult to retrofit. Handles only toilet wastes Residuals disposal.	Yearly removal and disposal of excreta in storage tank. Yearly maintenance of oil purification system by skilled technician. Power use = 0.01 Kwh/use.

^a None of these devices uses any water; therefore, the amount of flow reduction is equal to the amount of conventional toilet use: 16.2 gpcd or 36% of normal daily flow (45 gpcd). Significant quantities of pollutants (including N, BOD5, SS, P and pathogens) are therefore removed from wastewater stream.

^b 1 = Prototype developed and under evaluation.
 2 = Development complete; commercial production initiated, but distribution may be restricted; mail order purchase.
 3 = Fully developed; limited use, not locally available; mail order purchase likely.
 4 = Fully developed; limited use, available from local plumbing supply houses or hardware stores.
 5 = Fully developed; widespread use, available from local plumbing supply houses or hardware stores.

TABLE 5-4
WASTEWATER FLOW REDUCTION - BATHING DEVICES AND SYSTEMS

<u>Generic Type^a</u>	<u>Description</u>	<u>Develop- ment Stage^b</u>	<u>Application Considerations</u>	<u>Water Use gal/min</u>
Shower Flow Control Inserts and Restrictors	Reduce flow rate by reducing the diameter of supply line ahead of shower head. Varieties: Many.	4	Compatible with most existing showerheads. Installed by user.	1.5-3.0
Reduced-Flow Showerheads	Fixtures similar to conventional, except restrict flow rate. Varieties: Many manufacturers, but units similar.	4-5	Can match to most plumbing fixture appearance schemes. Compatible with most conventional plumbing.	1.5-3.0
ON/OFF Showerhead Valve	Small valve device placed in the supply line ahead of showerhead, allows shower flow to be turned ON/OFF without readjustment of volume or temperature.	4	Compatible with most conventional plumbing and fixtures. May be installed by user.	---
Thermostatically Controlled Mixing Valve	Specifically designed valve controls temperature of total flow according to predetermined setting. Valve may be turned ON/OFF without readjustment.	3	May be difficult to retrofit.	---

TABLE 5-4 (continued)

<u>Generic Type^a</u>	<u>Description</u>	<u>Development Stage^b</u>	<u>Application Considerations</u>	<u>Water Use gal/min</u>
Pressure-Balanced Mixing Valve	Specifically designed valve maintains constant temperature of total flow regardless of pressure changes. Single control allows temperature to be preset.	4	Compatible with most conventional plumbing and fixtures.	---
Air-Assisted Low-Flow Shower System	Specifically designed system uses compressed air to atomize water flow and provide shower sensation.	2	<p>May be impossible to retrofit.</p> <p>Shower location < 50 feet of water heater.</p> <p>Requires compressed air source.</p> <p>Power source required.</p> <p>Maintenance of air compressor.</p> <p>Power use = 0.01 Kwh/use.</p>	0.5

a No reduction in pollutant mass; slight increase in pollutant concentration.

b 1 = Prototype developed and under evaluation.

2 = Development complete; commercial production initiated, but distribution may be restricted; mail order purchase.

3 = Fully developed; limited use, not locally available; mail order purchase likely.

4 = Fully developed; limited use, available from local plumbing supply houses or hardware stores.

5 = Fully developed; widespread use, available from local plumbing supply houses or hardware stores.

5.2.2.3 Clotheswashing Devices and Systems

The operation of conventional clotheswashers consumes varying quantities of water depending on the manufacturer and model of the washer and the cycle selected. For most, water usage is 23 to 53 gal (87 to 201 l) per usage. Based on home water use monitoring, an average water use/wastewater flow volume of approximately 37 gal (140 l) per use has been identified, with the clotheswasher contributing about 10.0 gpcd (38 lpcd) or 22% of the total daily water use/wastewater flow (Table 4-2). Practical methods to reduce these quantities are somewhat limited. Eliminating wasteful water use habits, such as washing with only a partial load, is one method. Front-loading model automatic washers can reduce water used for a comparable load of clothes by up to 40%. In addition, wastewater flow reductions may be accomplished through use of a clotheswasher with either adjustable cycle settings for various load sizes or a wash water recycle feature.

The wash water recycle feature is included as an optional cycle setting on several commercially made washers. Selection of the recycle feature when washing provides for storage of the wash water from the wash cycle in a nearby laundry sink or a reservoir in the bottom of the machine, for subsequent use as the wash water for the next load. The rinse cycles remain unchanged. Since the wash cycle comprises about 45% of the total water use per operation, if the wash water is recycled once, about 17 gal (64 l) will be saved, if twice, 34 gal (129 l), and so forth. Actual water savings and wastewater flow reductions are highly dependent on the user's cycle selection.

5.2.2.4 Miscellaneous Devices and Systems

There are a number of additional devices, fixtures, and appliances available to help reduce wastewater flow volumes. These are directed primarily toward reducing the water flow rate through sink and basin faucets. Table 5-5 presents a summary of several of these additional flow reduction devices. Experience with these devices indicates that wastewater volume can be reduced by 1 to 2 gpcd (4 to 8 lpcd) when used for all sink and basin faucets.

5.2.3 Wastewater Recycle and Reuse Systems

Wastewater recycle and reuse systems collect and process the entire wastewater flow or the fractions produced by certain activities with storage for subsequent reuse. The performance requirements of any wastewater recycle system are established by the intended reuse activities. To simplify the performance requirements, most recycle

TABLE 5-5

WASTEWATER FLOW REDUCTION - MISCELLANEOUS DEVICES AND SYSTEMS

<u>Generic Type^a</u>	<u>Description</u>	<u>Develop- ment Stage^b</u>	<u>Application Considerations</u>
Faucet Inserts	Device which inserts into faucet valve or supply line and restricts flow rate with a fixed or pressure compensating orifice. Varieties: Many.	4	Compatible with most plumbing. Installation simple.
Faucet Aerators	Devices attached to faucet outlet which entrain air into water flow. Varieties: Many.	5	Compatible with most plumbing. Installation simple. Periodic cleaning of aerator screens.
Reduced-Flow Faucet Fixtures	Similar to conventional unit, but restrict flow rate with a fixed or pressure compensating orifice. Varieties: Many.	4	Compatible with most plumbing. Installation identical to conventional.

TABLE 5-5 (continued)

<u>Generic Type^a</u>	<u>Description</u>	<u>Develop- ment Stage^b</u>	<u>Application Considerations</u>
Mixing Valves	Specifically designed valve units which allow flow and temperature to be set with a single control. Varieties: Many.	5	Compatible with most plumbing. Installation identical to conventional.
Hot Water Pipe Insulation	Hot water piping is wrapped with insulation to reduce heat loss from hot water standing in pipe between uses. Varieties: Many.	4	May be difficult to retrofit.

a No reduction in pollutant mass; insignificant increase in pollutant concentration.

b 1 = Prototypes developed and under evaluation.

2 = Development complete; commercial production initiated, but distribution restricted.

3 = Fully developed, limited use, not locally available; mail order purchase likely.

4 = Fully developed, limited use, locally available from plumbing supply houses or hardware stores.

5 = Fully developed, widespread use, locally available from plumbing supply houses or hardware stores.

systems process only the wastewaters discharged from bathing, laundry, and bathroom sink usage, and restrict the use of the recycled water to flushing water-carriage toilets and possibly lawn irrigation. At the other extreme, systems are under development that process the entire wastewater flow and recycle it as a potable water source.

The flow sheets proposed for residential recycle systems are numerous and varied, and typically employ various combinations of the unit processes described in Chapter 6, complemented by specially designed control networks. In Table 5-6, several generic units are characterized according to their general recycle flow sheet.

5.3 Pollutant Mass Reduction

A second strategy for wastewater modification is directed toward decreasing the mass of potential pollutants at the source. This may involve the complete elimination of the pollutant mass contributed by a given activity or the isolation of the pollutant mass in a concentrated wastewater stream. In Table 5-7, several methods for pollutant mass reduction are outlined.

5.3.1 Improved User Habits

Unnecessary quantities of many pollutants enter the wastewater stream when materials, which could be readily disposed of in a solid waste form, are added to the wastewater stream. A few examples include flushing disposable diapers or sanitary napkins down the toilet, or using hot water and detergents to remove quantities of solidified grease and food debris from pots and pans to enable their discharge down the sink drain.

5.3.2 Cleaning Agent Selection

The use of certain cleansing agents can contribute significant quantities of pollutants. In particular, cleaning activities, such as clotheswashing and dishwashing, can account for over 70% of the phosphorus in residential wastewater (Table 4-4). Detergents are readily available that contain a low amount of phosphorus compared to other detergents.

TABLE 5-6

WASTEWATER FLOW REDUCTION - WASTEWATER RECYCLE AND REUSE SYSTEMS

<u>Flow Sheet Description</u>	<u>Develop- ment Stage^a</u>	<u>Application Considerations</u>	<u>Operation and Maintenance</u>	<u>Total Flow Reduction^b</u>		<u>Wastewater Quality Impacts</u>
				gpcd	%	
Recycle bath and laundry for toilet flushing	2	Requires separate toilet supply and drain line. May be difficult to retrofit to multi-story building. Requires wastewater disposal system for toilet and kitchen sink wastes.	Periodic replenishment of chemicals, cleaning of filters and storage tanks. Residuals disposal. Power use.	16	36	Sizable removals of pollutants, primarily P.
Recycle portion of total wastewater stream for toilet flushing	3	Requires separate toilet supply line. May be difficult to retrofit to multi-story building. Requires disposal system for unused recycle water.	Cleaning/replacement of filters and other treatment and storage components. Residuals disposal. Periodic replenishment of chemicals.	16	36	Significant removals of pollutants.

TABLE 5-6 (continued)

<u>Flow Sheet Description</u>	<u>Development Stage^a</u>	<u>Application Considerations</u>	<u>Operation and Maintenance</u>	<u>Total Flow Reduction^b</u> gpcd	<u>Wastewater Quality Impacts</u>
Recycle toilet wastewaters for flushing water carriage toilets	4	Requires separate toilet plumbing network. Utilizes low-flush toilets. Requires system for non-toilet wastewaters. May be difficult to retrofit. Application restricted to high use on multi-story installations.	Cleaning/replacement of filters and other treatment components. Residuals disposal. Power use.	16 36	Significant removals of pollutants.
Recycle total wastewater stream for all water uses	1-2	Requires major variance from State/local health codes for potable reuse. Difficult to retrofit.	All maintenance by skilled personnel. Routine service check. Periodic pump out and residuals disposal. Power use. Comprehensive monitoring program required.	45 100	No wastewater generated for on-site disposal.

^a 1 = Prototype developed and under evaluation.
 2 = Development complete; commercial production initiated, but distribution may be restricted.
 3 = Fully developed; limited use, not locally available, mail order purchase likely.
 4 = Fully developed; limited use, locally available from plumbing supply houses and hardware stores.
 5 = Fully developed; widespread use, locally available from plumbing supply houses and hardware stores.

^b Based on the normal waste flow information presented in Table 4-2.

TABLE 5-7

EXAMPLE POLLUTANT MASS REDUCTION METHODS

- I. Improved User Habits
- II. Cleaning Agent Selection
- III. Elimination of Garbage Disposal Appliance
- IV. Segregated Toilet Systems
 - A. Non-Water Carriage Toilets
 - B. Very Low-Volume Flush Toilets/Holding Tank
 - C. Closed Loop Wastewater Recycle Systems

5.3.3 Elimination of the Garbage Disposal Appliance

The use of a garbage disposal contributes substantial quantities of BOD₅ and suspended solids to the wastewater load (Table 4-4). As a result, it has been shown that the use of a garbage disposal may increase the rate of sludge and scum accumulation and produce a higher failure rate for conventional disposal systems under otherwise comparable conditions (6). For these reasons, as well as the fact that most waste handled by a garbage disposal could be handled as solid wastes, the elimination of this appliance is advisable.

5.3.4 Segregated Toilet Systems

Several toilet systems can be used to provide for segregation and separate handling of human excreta (often referred to as blackwater) and, in some cases, garbage wastes. Removal of human excreta from the wastewater stream serves to eliminate significant quantities of pollutants, particularly suspended solids, nitrogen, and pathogenic organisms (Table 4-4).

A number of potential strategies for management of segregated human excreta are presented in Figure 5-1. A discussion of the toilet systems themselves is presented in the wastewater flow reduction section of this chapter, while details regarding the other unit processes in the flow sheet may be found in Chapter 6.

Wastewaters generated by fixtures other than toilets are often referred to collectively as "graywater." Characterization studies have demonstrated that typical graywater contains appreciable quantities of organic matter, suspended solids, phosphorus and grease in a daily flow volume of 29 gpcd (110 lpcd) (7)(8)(9)(10)(11)(12)(13)(14)(15) (see Table 4-4). Its temperature as it leaves the residence is in the range of 31° C, with a pH slightly on the alkaline side. The organic materials in graywater appear to degrade at a rate not significantly different from those in combined residential wastewater (15). Microbiological studies have demonstrated that significant concentrations of indicator organisms as total and fecal coliforms are typically found in graywater (7)(11)(12)(13)(14)(15). One should assume, therefore, that graywater harbors pathogens.

Although residential graywater does contain pollutants and must be properly managed, graywater may be simpler to manage than total residential wastewater due to a reduced flow volume. While diverse strategies have been proposed for graywater management (Figure 5-21, rigorous field evaluations have not been conducted in most cases. Until further field data become available, it is recommended that graywater treatment and disposal/reuse systems be designed as for typical residential wastewater (as described in Chapter 6). Design allowances should be made only for the reductions in flow volume, as compared to typical residential wastewater.

5.4 Onsite Containment - Holding Tanks

Wastewaters may be contained on site using holding tanks, and then transported off site for subsequent treatment and disposal. In many respects, the design, installation, and operation of a holding tank is similar to that for a septic tank (as described in Chapter 6). Several additional considerations do exist, as indicated in Table 5-8. A discussion regarding the disposal of the pumpage from holding tanks is presented in Chapter 9 of this manual.

5.5 Reliability

An important aspect of wastewater modification concerns the reliability of a given method to yield a projected modification at a specific dwelling or establishment over the long term. This is of particular importance when designing an onsite wastewater disposal system based on modified wastewater characteristics.

FIGURE 5-1

EXAMPLE STRATEGIES FOR MANAGEMENT OF SEGREGATED HUMAN WASTES

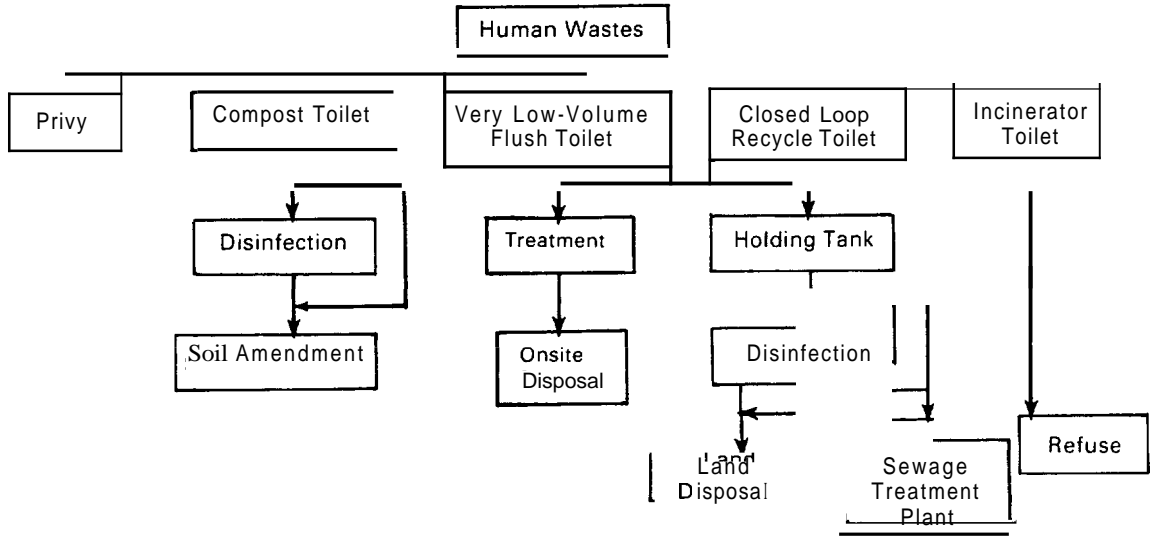

FIGURE 5-2

EXAMPLE STRATEGIES FOR MANAGEMENT OF RESIDENTIAL GRAYWATER

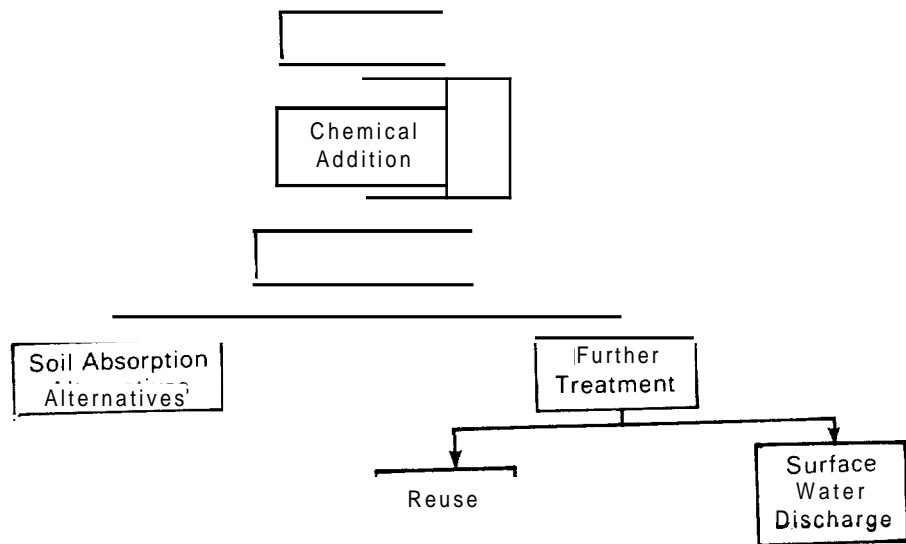

TABLE 5-8

ADDITIONAL CONSIDERATIONS IN THE DESIGN,
INSTALLATION, AND OPERATION OF HOLDING TANKS

<u>Item</u>	<u>Consideration</u>
Sizing	Liquid holding capacity >7 days wastewater flow generation. Minimum capacity = 1,000 gallons.
Discharge	There should be no discharge.
Alarm System	High water alarm positioned to allow at least 3 days storage after activation.
Accessibility	Frequent pumping is likely; therefore holding tank(s) must be readily accessible to pumping vehicle.
Flotation	Large tanks may be subject to severe flotation forces in high groundwater areas when pumped.
cost	Frequent pumping and residuals disposal results in very high operating costs.

Assessing the reliability of wastewater modification methods is a complex task which includes considerations of a technological, sociological, economic, and institutional nature. Major factors affecting reliability include:

1. The actual wastewater characteristics prior to modification compared to the average.
2. User awareness and influence on method performance.
3. Installation.
4. Method performance.
5. User circumvention or removal.

In most situations, projections of the impact of a wastewater modification method must necessarily be made, assuming the wastewater characteristics prior to modification are reasonably typical. If the actual wastewater characteristics deviate significantly from that of the average, a projected modification may be inaccurate.

The prospective user should be fully aware of the characteristics of a method considered for use prior to its application. Users who become aware of the characteristics of a method only after it has been put into use are more likely to be dissatisfied and attempt to circumvent or otherwise alter the method and negate the wastewater modification expected.

In general, passive wastewater modification methods or devices not significantly affected by user habits tend to be more reliable than those which are subject to user habits and require a preconceived active role by the users. For example, a low-flush toilet is a passive device, while a flow-reducing shower head is an active one.

Installation of any devices or systems should be made by qualified personnel. In many situations, a post-installation inspection is recommended to ensure proper functioning of the device or system.

Method performance is extremely important in assessing the reliability of the projected modification. Accurate performance data are necessary to estimate the magnitude of the reduction, and to predict the likelihood that the method will receive long-term user acceptance. Accurate performance data can only be obtained through the results of field testing and evaluations. Since many methods and system components are presently in various stages of development, only preliminary or projected operation and performance data may be available. This preliminary or projected data should be considered cautiously.

The continued employment of a wastewater modification method can be encouraged through several management actions. First, the user(s) should be made fully aware of the potential consequences if they should discontinue employing the modification method (e.g., system failure, water pollution, rejuvenation costs, etc.). Also, the appropriate management authority can approve only those methods whose characteristics and merits indicate a potential for long-term user acceptance. Further, installation of a device or system can be made in such a manner as to discourage disconnection or replacement. Finally, periodic inspections by a local inspector within the framework of a sanitary district or the like may serve to identify plumbing alterations; corrective orders could then be issued.

To help ensure that a projected modification will actually be realized at a given site, efforts can be expended to accomplish the following tasks:

1. Confirm that the actual wastewater characteristics prior to modification are typical.
2. Make the prospective user(s) of the modification method fully aware of the characteristics of the method, including its operation, maintenance, and costs.
3. Determine if the projected performance of a given method has been confirmed through actual field evaluations.
4. Ensure that any devices or systems are installed properly by competent personnel.
5. Prevent user removal or circumvention of devices, systems, or methods.

5.6 Impacts on Onsite Treatment and Disposal Practices

5.6.1 Modified Wastewater Characteristics

Reducing the household wastewater flow volume without reducing the mass of pollutants contributed will increase the concentration of pollutants in the wastewater stream. The increase in concentrations will likely be insignificant for most flow reduction devices with the exception of those producing flow reductions of 20% or more. The increase in pollutant concentrations in any case may be estimated utilizing Figure 5-3.

5.6.2 Wastewater Treatment and Disposal Practices

In Table 5-9, a brief summary of several potential impacts that wastewater modification may have on onsite disposal practices is presented. It must be emphasized that the benefits derived from wastewater modification are potentially significant. Wastewater modification methods, particularly wastewater flow reduction, should be considered an integral part of any onsite wastewater disposal system.

FIGURE 5-3

FLOW REDUCTION EFFECTS ON POLLUTANT CONCENTRATIONS

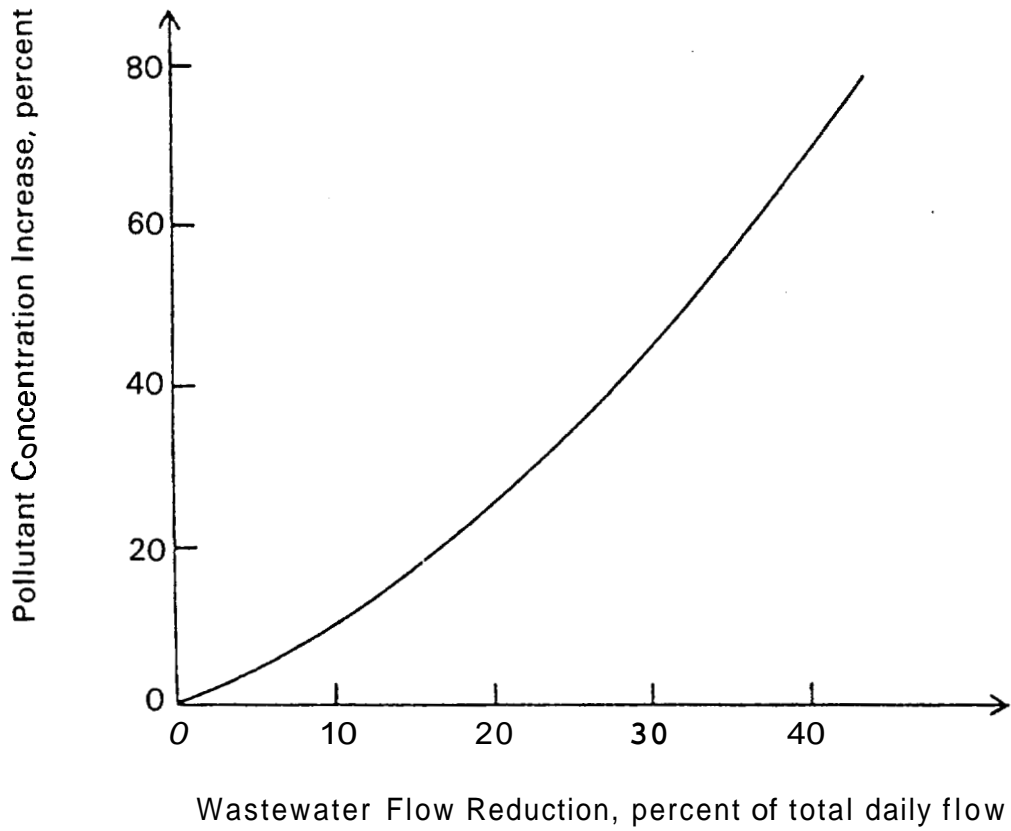

(Assumes Pollutant Contributions the Same Under the Reduced Flow Volume)

TABLE 5-9
 POTENTIAL IMPACTS OF WASTEWATER MODIFICATION
 ON ONSITE DISPOSAL PRACTICES

<u>Disposal System Type</u>	<u>Modification Practice</u>		<u>Potential Impact</u>
	<u>Flow Reduction</u>	<u>Pollutant Reduction</u>	
All Disposal	X	X	May extend service life of functioning system, but cannot quantify.
		X	Reduce water resource contamination.
		X	Simplify site constraints.
		X	Reduce frequency of septic tank pumping.
		X	Reduce sizing of infiltrative area.
		X	Remedy hydraulically overloaded system.
Surface Disposal	X	X	Reduce component O and M costs.
	X	X	Reduce sizing of components.
		X	Eliminate need for certain components (e.g., nitrogen removal).
	X		Remedy hydraulically overloaded system.
Evapotranspiration	X		Remedy a hydraulically overloaded system.
	X		Reduce sizing of ET area.
Onsite Containment	X		Reduce frequency of pumping.
	X		Reduce sizing of containment basin.

5.7 References

1. Wagner, E. G., and J. N. Lanoix. Excreta Disposal for Rural Areas and Small Communities. WHO Monograph 39, World Health Organization, Geneva, Switzerland, 1958. 187 pp.
2. Stoner, C. H. Goodbye to the Flush Toilet. Rodale Press, Emmaus, Pennsylvania, 1977.
3. Rybezynski, W., and A. Ortega. Stop the Five Gallon Flush. Minimum Coast Housing Group, School of Architecture, McGill University, Montreal, Canada, 1975.
4. Van Der Ryn, S. Compost Privy. Technical Bulletin No. 1, Farallones Institute, Occidental, California, 1974.
5. Rybezynski, W., C. Polprasert, and M. McGarry. Low-Cost Technical Options for Sanitation. Report IRDC-102e, International Development Research Center, Ottawa, Canada, 1978.
6. Bendixen, T. W., R. E. Thomas, A. A. McMahan, and J. B. Coulter. Effect of Food Waste Grinders on Septic Tank Systems. Robert A. Taft Sanitary Engineering Center, Cincinnati, Ohio, 1961. 119 pp.
7. Siegrist, R. L., M. Witt, and W. C. Boyle. Characteristics of Rural Housing Wastewater. J. Environ. Eng. Div., Am. Soc. Civil Eng., 102:553-548, 1976.
8. Laak, R. Relative Pollution Strengths of Undiluted Waste Materials Discharged in Households and the Dilution of Waters Used for Each. Manual of Grey Water Treatment Practice - Part II. Monogram Industries, Inc., Santa Monica, California, 1975.
9. Bennett, E. R., and E. K. Linstedt. Individual Home Wastewater Characterization and Treatment. Completion Report Series No. 66, Environmental Resources Center, Colorado State University, Fort Collins, 1975. 145 pp.
10. Ligman, K., N. Hutzler, and W. E. Boyle. Household Wastewater Characterization. J. Environ. Eng. Div., Am. Soc. Civil Eng., 150:201-213, 1974.
11. Olsson, E., L. Karlgren, and V. Tullander. Household Wastewater. National Swedish Institute for Building Research, Stockholm, Sweden, 1968.
12. Hypes, W. D., C. E. Batten, and J. R. Wilkins. The Chemical/Physical and Microbiological Characteristics of Bath and Laundry Wastewaters. NASA TN D-7566, Langley Research Center, Langley Center, Virginia, 1974. 31 pp.

13. Small Scale Waste Management Project, University of Wisconsin, Madison. Management of Small Waste Flows. EPA-600/2-78-173, NTIS Report No. PB 286 560, September 1978. 804 pp.
14. Brandes, M. Characteristics of Effluents from Separate Septic Tanks Treating Grey and Black Waters From the Same House. J. Water Pollut. Control Fed., 50:2547-2559, 1978.
15. Siegrist, R. L. Management of Residential Grey Water. Proceedings of the Second Pacific Northwest Onsite Wastewater Disposal Short Course, University of Washington, Seattle, March 1978.

CHAPTER 6
ONSITE TREATMENT METHODS

6.1 Introduction

This chapter presents information on the component of an onsite system that provides "treatment" of the wastewater, as opposed to its "disposal" (disposal options for treated wastewater are covered in Chapter 7). Treatment options included in this discussion are:

1. Septic tanks
2. Intermittent sand filters
3. Aerobic treatment units
4. Disinfection units
5. Nutrient removal systems
6. Wastewater segregation and recycle systems

Detailed design, O&M, performance, and construction data are provided for the first four components above. A more general description of nutrient removal is provided as these systems are not yet in general use, and often involve in-house changes in product use and plumbing. A brief mention of wastewater segregation and recycle options is included, since these also function as treatment options.

Options providing a combined treatment/disposal function, i.e., soil absorption systems, are discussed in Chapter 7.

6.1.1 Purpose

The purpose of the treatment component is to transform the raw household wastewater into an effluent suited to the disposal component, such that the wastewater can be disposed of in conformance with public health and environmental regulations. For example, in a subsurface soil absorption system, the pretreatment unit (e.g., septic tank) should remove nearly all settleable solids and floatable grease and scum so that a reasonably clear liquid is discharged into the soil absorption field. This allows the field to operate more efficiently. Likewise, for a surface discharge system, the treatment unit should produce an effluent that will meet applicable surface discharge standards.

6.1.2 Residuals

No treatment process is capable of continuous operation without experiencing some type of residuals buildup. Removal and disposal of these residuals is a very important and often neglected part of overall system O&M.

Residuals handling is discussed in detail under each individual component in Chapters 6 and 7. Final disposal of residuals is covered in Chapter 9.

6.2 Septic Tanks

6.2.1 Introduction

The septic tank is the most widely used onsite wastewater treatment option in the United States. Currently, about 25% of the new homes being constructed in this country use septic tanks for treatment prior to disposal of home wastewater.

This section provides detailed information on the septic tank, its siting considerations, performance, design, construction procedures, and operation and maintenance. The discussion centers on tanks for single-family homes; tanks for larger flows are discussed where they differ from the single-family model.

6.2.2 Description

Septic tanks are buried, watertight receptacles designed and constructed to receive wastewater from a home, to separate solids from the liquid, to provide limited digestion of organic matter, to store solids, and to allow the clarified liquid to discharge for further treatment and disposal. Settleable solids and partially decomposed sludge settle to the bottom of the tank and accumulate. A scum of lightweight material (including fats and greases) rises to the top. The partially clarified liquid is allowed to flow through an outlet structure just below the floating scum layer. Proper use of baffles, tees, and ells protects against scum outflow. Clarified liquid can be disposed of to soil absorption systems, soil mounds, lagoons, or other disposal systems. Leakage from septic tanks is often considered a minor factor; however, if tank leakage causes the level of the scum layer to drop below the outlet baffle, excessive scum discharges can occur. In the extreme case, the sludge layer will dry and compact, and normal tank cleaning

practices will not remove it (1). Another problem, if the tank is not watertight, is infiltration into the tank which can cause overloading of the tank and subsequent treatment and disposal components.

6.2.3 Application

Septic tanks are normally the first component of an onsite system. They must be followed by polishing treatment and/or disposal units. In most instances, septic tank effluent is discharged to a soil absorption field where the wastewater percolates down through the soil. In areas where soils are not suitable for percolation, septic tank effluent can be discharged to mounds or ET beds for treatment and disposal, or to filters or lagoons for further treatment.

Septic tanks are also amenable to chemical addition for nutrient removal, as discussed later in this manual.

Local regulatory agencies may require that the septic tank be located specified distances from home, water well, and water lines to reduce any risk of disease-causing agents from the septic tank reaching the potable water supply. A number of minimum separation distances have been developed for protecting water supplies and homes from septic tank disposal systems, but these are largely arbitrary and depend to a great degree on the soil conditions. Many state and local building codes feature suggested separation distances that should be adhered to in the absence of any extenuating circumstances.

6.2.4 Performance

Table 6-1 summarizes septic tank effluent quality. In addition to the tabulated results, bacterial concentrations in the effluent are not significantly changed since septic tanks cannot be relied upon to remove disease-causing microorganisms. Oil and grease removal is typically 70 to 80%, producing an effluent of about 20-25 mg/l. Phosphorus removal is slight, at about 15%, providing an effluent quality of about 20 mg/l total P.

Brandes (7) studied the quality of effluents from septic tanks treating graywater and blackwater. He found that without increasing the volume of the septic tank, the efficiency of the blackwater (toilet wastewater) treatment was improved by discharging the household graywater to a separate treatment disposal system.

TABLE 6-1

SUMMARY OF EFFLUENT DATA FROM VARIOUS SEPTIC TANK STUDIES

Parameter	Source				
	Ref. (2) 7 Sites	Ref. (3) 10 Tanks	Ref. (4) 19 Sites	Ref. (5) 4 Sites	Ref. (6) 1 Tank
BOD₅					
Mean, mg/l	138	138 ^a	140	240 ^b	120
Range, mg/l	7-480	64-256	--	70.385	30-280
No. of Samples	150	44	51	21	50
COD					
Mean, mg/l	327	--	--	--	200
Range, mg/l	25-780	--	--	--	71-360
No. of Samples	152	--	--	--	50
Suspended Solids					
Mean, mg/l	49	155 ^a	101	95 ^b	39
Range, mg/l	10-695	43-485	--	48-340	8-270
No. of Samples	148	55	51	18	47
Total Nitrogen					
Mean, mg/l	45	--	36	--	--
Range, mg/l	9-125	--	--	--	--
No. of Samples	99	--	51	--	--

^a Calculated from the average values from 10 tanks, 6 series of tests.

^b Calculated on the basis of a log-normal distribution of data.

Factors affecting septic tank performance include geometry, hydraulic loading, inlet and outlet arrangements, number of compartments, temperature, and operation and maintenance practices. If a tank is hydraulically overloaded, retention time may become too short and solids may not settle or float properly.

A single-compartment tank will give acceptable performance. However, multi-compartment tanks perform somewhat better than single-compartment tanks of the same total capacity, because they provide better protection against solids carry-over into discharge pipes during periods of surges or upset due to rapid digestion.

Improper design and placement of baffles can create turbulence in the tank, seriously impairing settling efficiency. In addition, poor baffles or outlet devices may promote scum or sludge entry to discharge pipes. Obviously, improper operation and maintenance will impair performance. Flushing problem wastes (paper towels, bones, fats, diapers, etc.) into the system can clog piping. Failure to pump out accumulated solids will eventually lead to problems with solids discharge in the effluent.

6.2.5 Design

6.2.5.1 General

Septic tanks for single-family homes are usually purchased "off the shelf," ready for installation, and are normally designed in accordance with local codes.

The tank must be designed to ensure removal of almost all settleable solids. To accomplish this, the tank must provide:

1. Liquid volume sufficient for a 24-hr fluid retention time at maximum sludge depth and scum accumulation (8).
2. Inlet and outlet devices to prevent the discharge of sludge or scum in the effluent.
3. Sufficient sludge storage space to prevent the discharge of sludge or scum in the effluent.
4. Venting provisions to allow for the escape of accumulated methane and hydrogen sulfide gases.

6.2.5.2 Criteria

The first step in selecting a tank volume is to determine the average volume of wastewater produced per day. Ideally, this is done by metering wastewater flows for a given period; but that is seldom feasible, particularly if a septic tank system is being selected for a building still under construction.

In the past, the design capacity of most septic tanks was based on the number of bedrooms per home and the average number of persons per bedroom. Chapter 4 showed that the average wastewater contribution is about 45 gpcd (170 lpcd) (2). As a safety factor, a value of 75 gpcd (284 lpcd) can be coupled with a potential maximum dwelling density of two persons per bedroom, yielding a theoretical design flow of 150 gal/bedroom/day (570 l/bedroom/day). A theoretical tank volume of 2 to 3 times the design daily flow is common, resulting in a total tank design capacity of 300 to 450 gal per bedroom (1,140 to 1,700 l per bedroom).

While not ideal, most state and local codes rely on some version of this method by assigning required septic tank capacities solely by the number of bedrooms (see Table 6-2). Unfortunately, hourly and daily flows from the home can vary greatly. During high flow periods, higher solids concentrations are discharged from the septic tank. Well-designed, two-compartment tanks reduce the effect of peak hour loads.

Another key factor in the design and performance of septic tanks is the relationship between surface area, surge storage, discharge rate, and exit velocity. These parameters affect the hydraulic efficiency and sludge retention capacity of the tank.

Tanks with greater surface area and shallower depth are preferred, because increased liquid surface area increases surge storage capacity; a given inflowing volume creates a smaller rise in water depth and a slower discharge rate and exit velocity. These surges of flow through the tank are dampened as surface area increases. This allows a longer time for separation of sludge and scum that are mixed by turbulence resulting from the influent surge (8).

In addition to increasing the surface area, there are two other means of reducing the exit velocity and reducing the opportunity for solids and scum to escape through the outlet. These are: 1) increase the size of the outlet riser; and 2) reduce the size of the final discharge pipe. The use of a 6-in. (15-cm) outlet riser instead of a 4-in. (10-cm).

TABLE 6-2
TYPICAL SEPTIC TANK LIQUID VOLUME REQUIREMENTS

	<u>Federal Housing Authority</u>	<u>U.S. Public Health Service</u>	<u>Uniform Plumbing Code</u>	<u>Range of State Requirements (9)</u>
Minimum, gal	750	750	750	500 - 1,000
1-2 bedrooms, gal	750	750	750	500 - 1,000
3 bedrooms, gal	900	900	1,000	900 - 1,500
4 bedrooms, gal	1,000	1,000	1,200	1,000 - 2,000
5 bedrooms, gal	1,250	1,250	1,500	1,100 - 2,000
Additional bedrooms (ea), gal	250	250	150	-

outlet riser will reduce the exit velocity from 0.025 ft/sec to 0.011 ft/sec (0.76 cm/sec to 0.34 cm/sec) a reduction of 56% (8).

Use of garbage grinders increases both the settleable and floatable solids in the wastewater and their accumulation rates in the septic tank. U.S. Public Health Service (USPHS) studies indicate that the increase in the sludge and scum accumulation rate is about 37% (10). This means either more frequent pumping or a larger tank to keep the pumping frequency down. A common expedient is to add 250 gal (946 l) to the tank size when garbage grinders are used, although this volume is arbitrary. It is generally a good idea to avoid the use of garbage grinders with onsite systems.

6.2.5.3 Inlet and Outlet Devices

The flow out of a septic tank should carry only minimal concentrations of settleable solids. Higher concentrations can occur if:

1. The inlet turbulence in a single-compartment tank causes mixing of the sludge with the wastewater in the clear space.
2. The rise velocity of the water in the vertical leg of the outlet tee resuspends previously captured solids.
3. The rising gases produced by anaerobic digestion interfere with particle-settling and resuspend previously captured solids, which then are lost in the effluent.

The inlet to a septic tank should be designed to dissipate the energy of the incoming water, to minimize turbulence, and to prevent short-circuiting. The inlet should preferably be either a sanitary tee or baffle. The baffle should be small enough so that it is flushed out each time, and yet keeps floating solids from blocking the inlet. The invert radius in a tee helps dissipate energy in the transition from horizontal to vertical flow, and prevents dripping that, at the proper frequency, can amplify water surface oscillations and increase intercompartmental mixing. The vertical leg of the inlet tee should extend below the liquid surface. This minimizes induced turbulence by dissipating as much energy in the inlet as possible.

The outlet structure's ability to retain sludge and scum in either the first or second compartment is a major factor in overall task performance. The outlet of a septic tank can be a tee, a baffle, or some special structure (see Figure 6-1). The outlet must have the proper submergence and height above liquid level such that the sludge

FIGURE 6-1

TYPICAL SEPTIC TANK OUTLET STRUCTURES TO MINIMIZE SUSPENDED SOLIDS IN DISCHARGE (11)

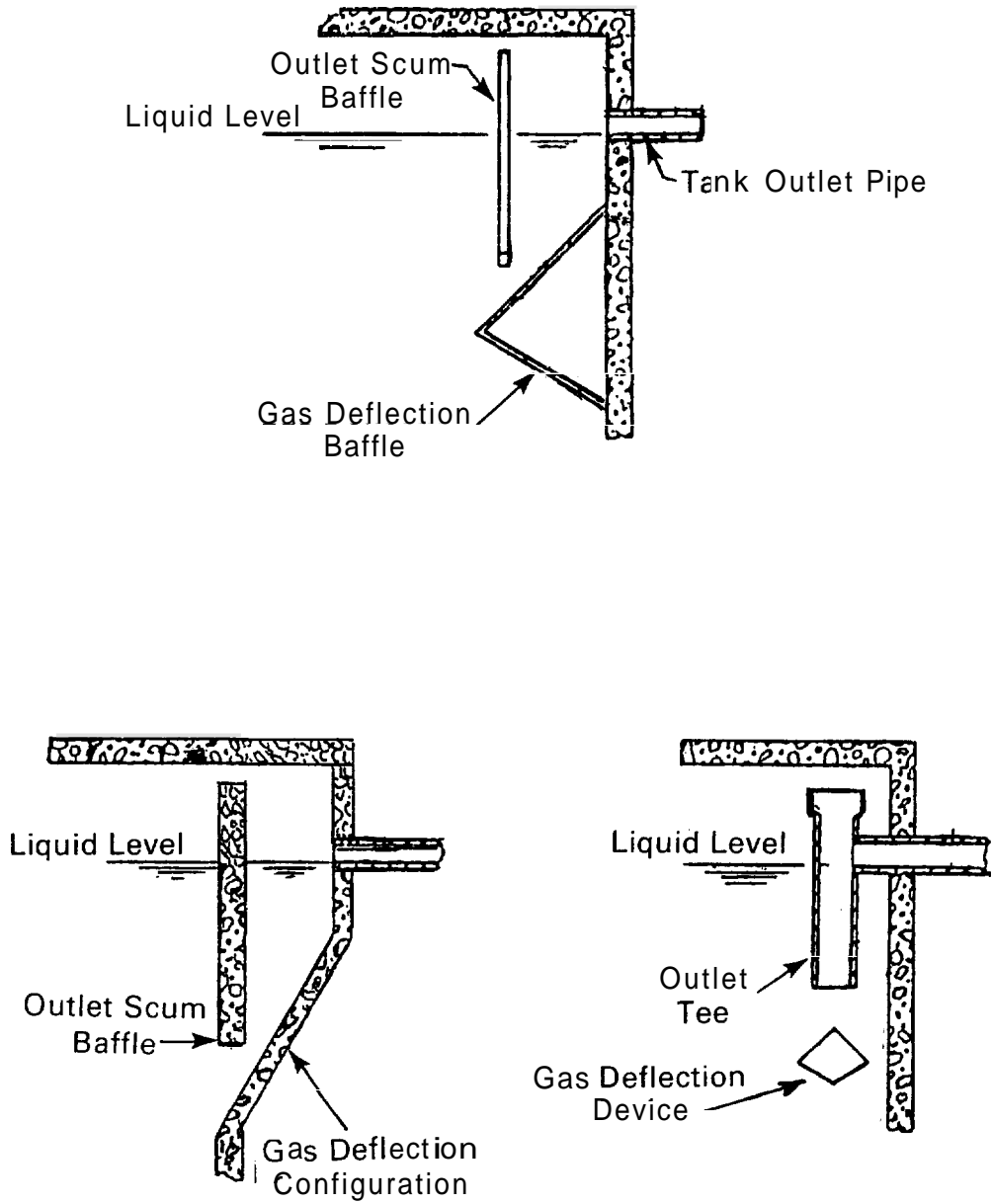

and scum clear spaces balance, and proper venting of sludge gases is provided (see Figure 6-2). Although the Manual of Septic Tank Practices recommends an outlet submergence equal to 40% of the liquid depth, other studies have shown that shallower submergence decreases solids discharges and allows for greater sludge accumulation, and thus for less frequent pumping (8). Table 6-3 summarizes the results of these studies.

As shown in Figure 6-1, various types of gas deflection baffles and wedges have been developed to prevent gas-disturbed sludge from entering the rising leg of the outlet.

6.2.5.4 Compartmentation

Recent trends in septic tank design favor multiple, rather than single, compartmented tanks. When a tank is properly divided into compartments, BOD and SS removal are improved. Figure 6-3 shows a typical two-compartment tank.

The benefits of compartmentation are due largely to hydraulic isolation, and to the reduction or elimination of intercompartmental mixing. Mixing can occur by two means: water oscillation and true turbulence. Oscillatory mixing can be minimized by making compartments unequal in size (commonly the second compartment is $1/3$ to $1/2$ the size of the first), reducing flow-through area, and using an ell to connect compartments (1).

In the first compartment, some mixing of sludge and scum with the liquid always occurs due to induced turbulence from entering wastewater and the digestive process. The second compartment receives the clarified effluent from the first compartment. Most of the time it receives this hydraulic load at a lower rate and with less turbulence than does the first compartment, and, thus, better conditions exist for settling low-density solids. These conditions lead to longer working periods before pump-out of solids is necessary and improve overall performance.

6.2.5.5 Access and Inspection

In order to provide access and a means to inspect the inside of the septic tank, manholes should be provided. Manholes are usually placed over both the inlet and the outlet to permit cleaning behind the baffles. The manhole cover should extend above the actual septic tank to a height not more than 6 in. (15 cm) below the finished grade. The actual cover can extend to the ground surface if a proper seal is provided to prevent

FIGURE 6-2
 SEPTIC TANK SCUM AND SLUDGE CLEAR SPACES (8)

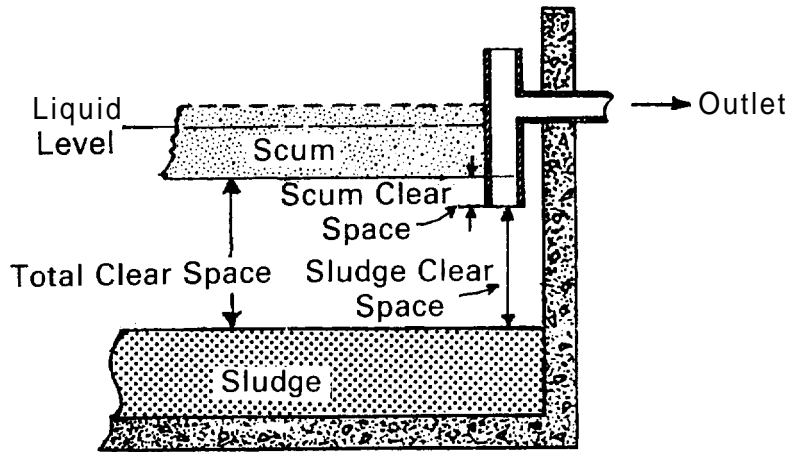

TABLE 6-3
 LOCATION OF TOP AND BOTTOM OF OUTLET TEE OR BAFFLE (12)

Total Liquid Tank Capacity gal	Tank Receiving Sewage		Tank Receiving Sewage and Garbage	
	Projection ^a Above Liquid Level	Penetration ^a Below Liquid Level	Projection ^a Above Liquid Level	Penetration ^a Below Liquid Level
500	12	22	--	--
750	12	24	18	38
1,000	12	26	18	41

^a Percentage of liquid depth. See Figure 6-2 for diagram.

FIGURE 6-3

TYPICAL TWO-COMPARTMENT SEPTIC TANK

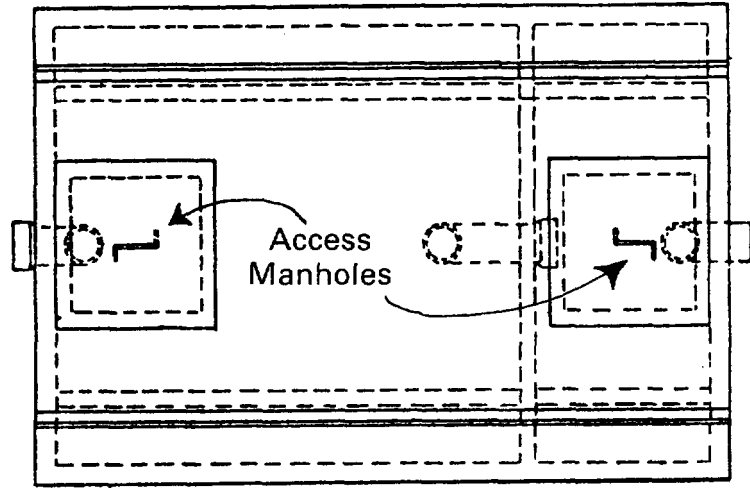

Plan

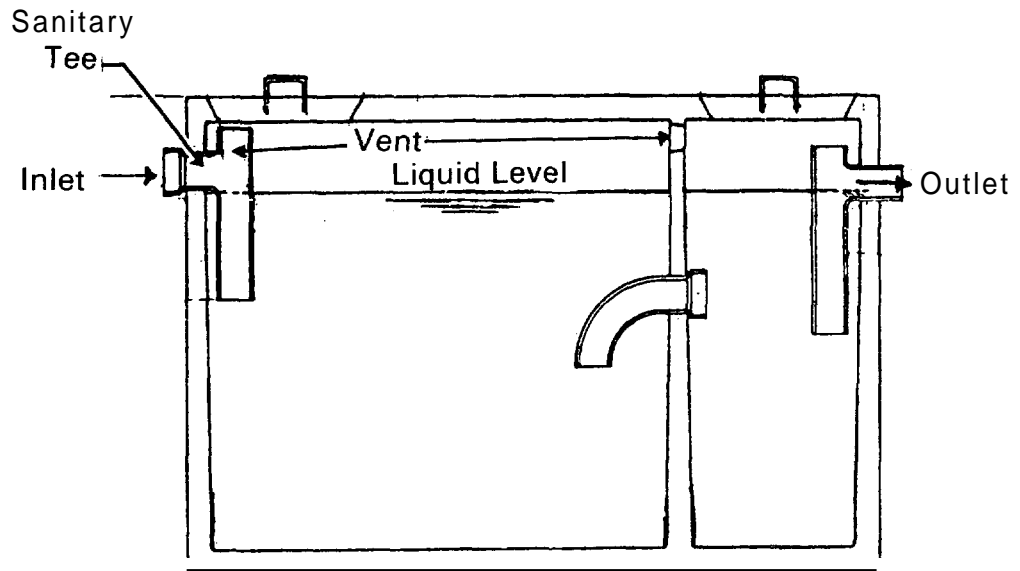

Longitudinal Section

the escape of odors and accidental entry into the tank. In addition, small inspection pipes can be placed over the inlet and outlet to allow inspection without having to remove the manhole.

6.2.5.6 Materials

The most commonly used construction material for septic tanks is concrete. Virtually all individual-home septic tanks are precast for easy installation in the field. The walls have a thickness of 3 to 4 in. (8 to 10 cm), and the tank is sealed for watertightness after installation with two coats of bituminous coating. Care must be taken to seal around the inlet and discharge pipes with a bonding compound that will adhere both to concrete and to the inlet and outlet pipe.

Steel is another type of material that has been used for septic tanks. The steel must be treated so as to be able to resist corrosion and decay. Such protection includes bituminous coating or other corrosion-resistant treatment. However, despite a corrosion-resistant coating, tanks deteriorate at the liquid level. Past history indicates that steel tanks have a short operational life (less than 10 years) due to corrosion (3).

Other materials include polyethylene and fiberglass. Plastic and fiberglass tanks are very light, easily transported, and resistant to corrosion and decay. While these tanks have not had a good history, some manufacturers are now producing an excellent tank with increased strength. This minimizes the chance of damage during installation or when heavy machinery moves over it after burial.

6.2.6 Installation Procedures

The most important requirement of installation is that the tank be placed on a level grade and at a depth that provides adequate gravity flow from the home and matches the invert elevation of the house sewer. The tank should be placed on undisturbed soil so that settling does not occur. If the excavation is dug too deep, it should be backfilled to the proper elevation with sand to provide an adequate bedding for the tank. Tank performance can be impaired if a level position is not maintained, because inlet and outlet structures will not function properly.

Other considerations include:

1. Cast iron inlet and outlet structures should be used in disturbed soil areas where tank settling may occur.
2. Flotation collars should be used in areas with high groundwater potential.
3. The tank should be placed so that the manhole is slightly below grade to prevent accidental entry.
4. The tank should be placed in an area with easy access to alleviate pump-out problems.
5. During installation, any damage to the watertight coating should be repaired. After installation, the tank should be tested for watertightness by filling with water.
6. Care should be taken with installation in areas with large rocks to prevent undue localized stresses.
7. Baffles, tees, and elbows should be made of durable and corrosion-proof materials. Fiberglass or acid-resistant concrete baffle materials are most suitable. Vitrified clay tile, plastic, and cast iron are best for tees and elbows.

6.2.7 Operation and Maintenance

One of the major advantages of the septic tank is that it has no moving parts and, therefore, needs very little routine maintenance. A well-designed and maintained concrete, fiberglass, or plastic tank should last for 50 years. Because of corrosion problems, steel tanks can be expected to last no more than 10 years. One cause of septic tank problems involves a failure to pump out the sludge solids when required. As the sludge depth increases, the effective liquid volume and detention time decrease. As this occurs, sludge scouring increases, treatment efficiency falls off, and more solids escape through the outlet. The only way to prevent this is by periodic pumping of the tank.

Tanks should be inspected at intervals of no more than every 2 years to determine the rates of scum and sludge accumulation. If inspection programs are not carried out, a pump-out frequency of once every 3 to 5 years is reasonable. Once the characteristic sludge accumulation rate is known, inspection frequency can be adjusted accordingly. The inlet and outlet structures and key joints should be inspected for damage after each tank pump-out.

Actual inspection of sludge and scum accumulations is the only way to determine definitely when a given tank needs to be pumped. When a tank is inspected, the depth of sludge and scum should be measured in the vicinity of the outlet baffle. The tank should be cleaned whenever: (1) the bottom of the scum layer is within 3 in. of the bottom of the outlet device; or (2) the sludge level is within 8 in. of the bottom of the outlet device. The efficiency of suspended solids removal may start to decrease before these conditions are reached.

Scum can be measured with a stick to which a weighted flap has been hinged, or with any device that can be used to feel the bottom of the scum mat. The stick is forced through the mat, the hinged flap falls into a horizontal position, and the stick is raised until resistance from the bottom of the scum is felt. With the same tool, the distance to the bottom of the outlet device can be determined.

A long stick wrapped with rough, white toweling and lowered to the bottom of the tank will show the depth of sludge and the liquid depth of the tank. The stick should be lowered behind the outlet device to avoid scum particles. After several minutes, the sludge layer can be distinguished by sludge particles clinging to the toweling.

Other methods for measuring sludge include connecting a small pump to a clear plastic line and lowering the line until the pump starts to draw high solids concentrations.

Following is a list of considerations pertaining to septic tank operation and maintenance:

1. Climbing into septic tanks can be very dangerous, as the tanks are full of toxic gases. When using the manhole, take every precaution possible, i.e., do not lower an individual into the tank without a proper air supply, and safety rope tied around chest or waist.
2. The manhole, not the inspection pipe, should be used for pumping so as to minimize the risk of harm to the inlet and outlet baffles.
3. Leaving solids in the septic tank to aid in starting the system is not necessary.
4. When pumped, the septic tank must not be disinfected, washed, or scrubbed.

5. Special chemicals are not needed to start activity in a septic tank.
6. Special additives are not needed to improve or assist tank operation once it is under way. No chemical additives are needed to "clean" septic tanks. Such compounds may cause sludge bulking and decreased sludge digestion. However, ordinary amounts of bleaches, lyes, caustics, soaps, detergents, and drain cleaners do not harm the system. Other preparations, some of which claim to eliminate the need for septic tank pumping, are not necessary for proper operation and are of questionable value.
7. Materials not readily decomposed (e.g., sanitary napkins, coffee grounds, cooking fats, bones, wet-strength towels, disposable diapers, facial tissues, cigarette butts) should never be flushed into a septic tank. They will not degrade in the tank, and can clog inlets, outlets, and the disposal systems.

6.2.8 Considerations for Multi-Home and Commercial Wastewater

6.2.8.1 General

In some instances, a septic tank can serve several homes, or a commercial/institutional user such as a school, store, laundry, or restaurant. Whereas septic tanks for single-family homes must handle highly variable flows (i.e., approximately 45% of the total household flow occurs in the peak four hours), commercial systems must also be able to treat continuous wastewater flows for 8-16 hours a day as well as peak loadings. In addition, commercial wastewaters may present special problems that need to be handled prior to discharge to the septic tank (i.e., grease removal for restaurant wastewaters, and lint removal for laundry wastewater).

As explained previously, septic tanks of two compartments give better results than single-compartment tanks. Although single-compartment tanks are acceptable for small household installations, tanks with two compartments should be provided for the larger institutional systems. Tanks with more than two compartments are not used frequently.

Multiple-compartment tanks for commercial/institutional flows should have the same design features as single-family home tanks discussed above. These include: compartments separated by walls with ports or slits at proper elevations, proper venting, access to all compartments, and proper inlet and outlet design and submergence.

The effect of a multiple-compartment tank can be accomplished by using two or more tanks in series. A better construction arrangement, particularly for medium or large installations, is to connect special tank sections together into a unit having single end-walls and two compartments. A unit of four precast tank sections forming two compartments is shown in Figure 6-4.

6.2.8.2 Design

Larger tanks for commercial/institutional flows or for clusters of homes must be sized for the intended flow. Whenever possible with existing facilities, the flow should be metered to obtain accurate readings on average daily flows and flow peaks. For housing clusters, if the total flow cannot be measured, the individually metered or estimated flows (based on the expected population and the generation rate of 45 gal/cap/day (170 l/cap/day) from each house must be summed to determine the design flow. For commercial/institutional applications, consult Chapter 4. For flows between 750 and 1,500 gal per day (2,840 to 5,680 l per day), the capacity of the tank is normally equal to 1-1/2 days wastewater flow. For flows between 1,500 and 15,000 gpd (5,680 to 56,800 lpd), the minimum effective tank capacity can be calculated at 1,125 gal (4,260 l) plus 75% of the daily flow; or

$$V = 1,125 + 0.75Q$$

where:

V = net volume of the tank (gal)
Q = daily wastewater flow (gal)

If garbage grinders are used, additional volume or extra sludge storage may be desired to minimize the frequency of pumping (10).

6.3 Intermittent Sand Filters

6.3.1 Introduction

Intermittent sand filtration may be defined as the intermittent application of wastewater to a bed of granular material which is underdrained to collect and discharge the final effluent. One of the oldest methods of wastewater treatment known, intermittent sand filtration, if properly designed, operated, and constructed, will produce effluents of very high quality. Currently, many intermittent sand filters are used throughout the United States to treat wastewater from small commercial and institutional developments and from individual

FIGURE 6-4

FOUR PRECAST REINFORCED CONCRETE SEPTIC TANKS COMBINED
INTO ONE UNIT FOR LARGE FLOW APPLICATION (10)

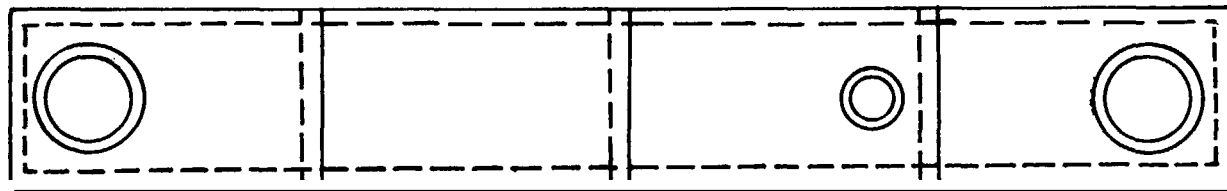

Plan

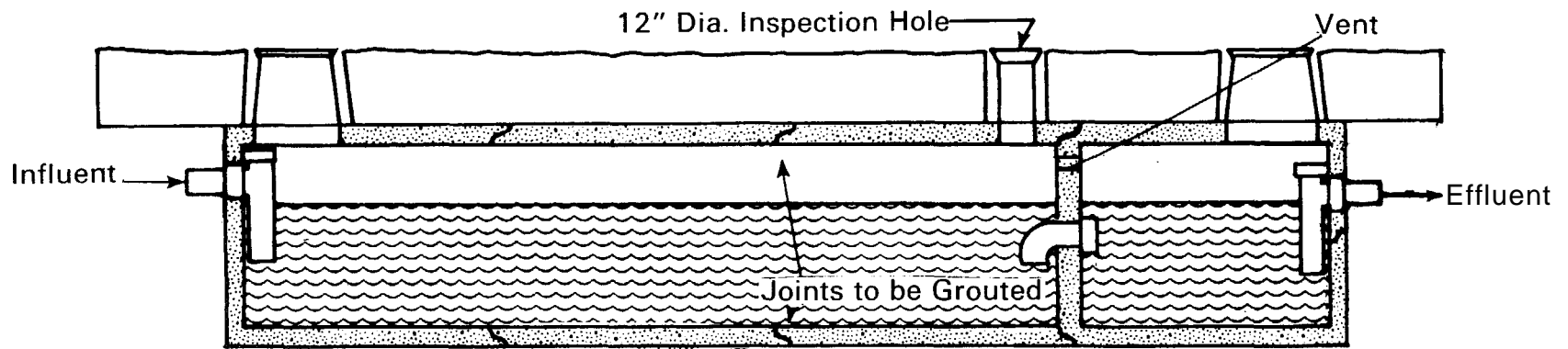

Section

homes. The use of intermittent sand filters for upgrading stabilization ponds has also become popular (13).

Intermittent sand filtration is well suited to onsite wastewater treatment and disposal. The process is highly efficient, yet requires a minimum of operation and maintenance. Normally, it would be used to polish effluents from septic tank or aerobic treatment processes and would be followed by disinfection (as required) prior to reuse or disposal to land or surface waters.

6.3.2 Description

Intermittent sand filters are beds of granular materials 24 to 36 in. (61 to 91 cm) deep and underlain by graded gravel and collecting tile. Wastewater is applied intermittently to the surface of the bed through distribution pipes or troughs. Uniform distribution is normally obtained by dosing so as to flood the entire surface of the bed.

Filters may be designed to provide free access (open filters), or may be buried in the ground (buried filters). A relatively new concept in filtration employs recirculation of filter effluent (recirculating filters).

The mechanisms of purification attained by intermittent sand filters are complex and not well understood even today. Filters provide physical straining and sedimentation of solid materials within the media grains. Chemical sorption also plays a role in the removal of some materials. However, successful treatment of wastewaters is dependent upon the biochemical transformations occurring within the filter. Without the assimilation of filtered and sorbed materials by biological growth within the filter, the process would fail to operate properly. There is a broad range of trophic levels operating within the filter, from the bacteria to annelid worms.

Since filters entrap, sorb, and assimilate materials in the wastewater, it is not surprising to find that the interstices between the grains may fill, and the filter may eventually clog. Clogging may be caused by physical, chemical, and biological factors. Physical clogging is normally caused by the accumulation of stable solid materials within or on the surface of the sand. It is dependent on grain size and porosity of the filter media, and on wastewater suspended solids characteristics. The precipitation, coagulation, and adsorption of a variety of materials in wastewater may also contribute to the clogging problem in some filter operations (14). Biological clogging is due primarily to an improper

balance of the intricate biological population within the filter. Toxic components in the wastewater, high organic loading, absence of dissolved oxygen, and decrease in filter temperatures are the most likely causes of microbial imbalances. Accumulation of biological slimes and a decrease in the rate of decomposition of entrapped wastewater contaminants within the filter accelerates filter clogging. All forms of pore clogging likely occur simultaneously throughout the filter bed. The dominant clogging mechanism is dependent upon wastewater characteristics, method and rate of wastewater application, characteristics of the filtering media, and filter environmental conditions.

6.3.3 Application

Intermittent sand filtration is well adapted to onsite disposal. Its size is limited by land availability. The process is applicable to single homes and clusters of dwellings. The wastewater applied to the intermittent filters should be pretreated at least by sedimentation. Septic tanks should be required as a minimum. Additional pretreatment by aerobic biological processes normally results in higher acceptable rates of wastewater application and longer filter runs. Although extensive field experience is lacking to date, the application of pretreated graywaters to intermittent sand filters may be advantageously employed. There is some evidence that higher loading rates and longer filter runs can be achieved with pretreated graywaters.

Site constraints should not limit the application of intermittent sand filters, although odors from open filters receiving septic tank effluent may require isolation of the process from dwellings. Filters are often partially (or completely) buried in the ground, but may be constructed above ground when dictated by shallow bedrock or high water tables. Covered filters are required in areas with extended periods of subfreezing weather. Excessive long-term rainfall and runoff on submerged filter systems may be detrimental to performance, requiring appropriate measures to divert these sources away from the system.

6.3.4 Factors Affecting Performance

The degree of stabilization attained by an intermittent sand filter is dependent upon: (1) the type and biodegradability of wastewater applied to the filter, (2) the environmental conditions within the filter, and (3) the design characteristics of the filter.

Reaeration and temperature are two of the most important environmental conditions that affect the degree of wastewater purification through an intermittent sand filter. Availability of oxygen within the pores

allows for the aerobic decomposition of the wastewater. Temperature directly affects the rate of microbial growth, chemical reactions, adsorption mechanisms, and other factors that contribute to the stabilization of wastewater within the sand media.

Proper selection of process design variables also affects the degree of purification of wastewater by intermittent filters. A brief discussion of those variables is presented below.

6.3.4.1 Media Size and Distribution

The successful use of a granular material as a filtering media is dependent upon the proper choice of size and uniformity of the grains. Filter media size and uniformity are expressed in terms of "effective size" and "uniformity coefficient." The effective size is the size of the grain, in millimeters, such that 10% by weight are smaller. The uniformity coefficient is the ratio of the grain size that has 60% by weight finer than itself to the size which has 10% finer than itself. The effective size of the granular media affects the quantity of wastewater that may be filtered, the rate of filtration, the penetration depth of particulate matter, and the quality of the filter effluent. Granular media that is too coarse lowers the retention time of the applied wastewater through the filter to a point where adequate biological decomposition is not attained. Too fine a media limits the quantity of wastewater that may be successfully filtered, and will lead to early filter clogging. This is due to the low hydraulic capacity and the existence of capillary saturation, characteristic of fine materials. Metcalf and Eddy (15) and Boyce (16) recommended that not more than 1% of the media should be finer than 0.13 mm. Many suggested values for the effective size and uniformity coefficient exist in the literature (10)(17)(18)(18)(20). Recommended filter media effective sizes range from a minimum of 0.25 mm up to approximately 1.5 mm. Uniformity coefficients (UC) for intermittent filter media normally should be less than 4.0.

Granular media other than sand that have been used include anthracite, garnet, ilmenite, activated carbon, and mineral tailings. The media selected should be durable and insoluble in water. Total organic matter should be less than 1%, and total acid soluble matter should not exceed 3%. Any clay, loam, limestone, or organic material may increase the initial adsorption capacity of the sand, but may lead to a serious clogging condition as the filter ages.

Shapes of individual media grains include round, oval, and angular configurations. Purification of wastewater infiltrating through granular media is dependent upon the adsorption and oxidation of organic matter in the wastewater. To a limiting extent, this is dependent on the shape

of the grain; however, it is more dependent on the size distribution of the grains, which is characterized by the UC.

The arrangement or placement of different sizes of grains throughout the filter bed is also an important design consideration. A homogeneous bed of one effective size media does not occur often due to construction practices and variations in local materials. In a bed having fine media layers placed above coarse layers, the downward attraction of wastewater is not as great due to the lower amount of cohesion of the water in the larger pores (21). The coarse media will not draw the water out of the fine media, thereby causing the bottom layers of the fine material to remain saturated with water. This saturated zone acts as a water seal, limits oxidation, promotes clogging, and reduces the action of the filter to a mere straining mechanism. The use of media with a UC of less than 4.0 minimizes this problem.

The media arrangement of coarse over fine appears theoretically to be the most favorable, but it may be difficult to operate such a filter due to internal clogging throughout the filter.

6.3.4.2 Hydraulic Loading Rate

The hydraulic loading rate may be defined as the volume of liquid applied to the surface area of the sand filter over a designated length of time. Hydraulic loading is normally expressed as gpd/ft², or cm/day. Values of recommended loading rates for intermittent sand filtration vary throughout the literature and depend upon the effective size of sand and the type of wastewater. They normally range from 0.75 to 15 gpd/ft (0.3 to 0.6 m³/m²/d).

6.3.4.3 Organic Loading Rate

The organic loading rate may be defined as the amount of soluble and insoluble organic matter applied per unit volume of filter bed over a designated length of time. Organic loading rates are not often reported in the literature. However, early investigators found that the performance of intermittent sand filters was dependent upon the accumulation of stable organic material in the filter bed (14)(21). To account for this, suggested hydraulic loading rates today are often given for a particular type of wastewater. Allowable loading rates increase with the degree of pretreatment. A strict relationship establishing an organic loading rate, however, has not yet been clearly defined in the literature.

6.3.4.4 Depth of Media

Depths of intermittent sand filters were initially designed to be 4 to 10 feet; however, it was soon realized at the Lawrence Experimental Station (21) that most of the purification of wastewater occurred within the top 9 to 12 in. (23 to 30 cm) of the bed. Additional bed depth did not improve the wastewater purification to any significant degree. Most media depths used today range from 24 to 42 in. (62 to 107 cm). The use of shallow filter beds helps to keep the cost of installation low. Deeper beds tend to produce a more constant effluent quality, are not affected as severely by rainfall or snow melt (22), and permit the removal of more media before media replacement becomes necessary.

6.3.4.5 Dosing Techniques and Frequency

Dosing techniques refer to methods of application of wastewater to the intermittent sand filter. Dosing of intermittent filters is critical to the performance of the process. The system must be designed to insure uniform distribution of wastewater throughout the filter cross-section. Sufficient resting must also be provided between dosages to obtain aerobic conditions. In small filters, wastewater is applied in doses large enough to entirely flood the filter surface with at least 3 in. (8 cm) of water, thereby insuring adequate distribution. Dosing frequency is dependent upon media size, but should be greater with smaller doses for coarser media.

Dosing methods that have been used include ridge and furrow application, drain tile distribution, surface flooding, and spray distribution methods. Early sand filters for municipal wastewater were surface units that normally employed ridge and furrow or spray distribution methods. Intermittent filters in use today are often built below the ground surface and employ tile distribution.

The frequency of dosing intermittent sand filters is open to considerable design judgement. Most of the earlier studies used a dosing frequency of 1/day. The Florida studies investigated multiple dosings and concluded that the BOD removal efficiency of filters with media effective size greater than 0.45 mm is appreciably increased when the frequency of loading is increased beyond twice per day (23). This multiple dosing concept is successfully used in recirculating sand filter systems in Illinois (24), which employ a dosing frequency of once every 30 min.

6.3.4.6 Maintenance Techniques

Various techniques to maintain the filter bed may be employed when the bed becomes clogged. Some of these include: (1) resting the bed for a period of time, (2) raking the surface layer and thus breaking the inhibiting crust, or (3) removing the top surface media and replacing it with clean media. The effectiveness of each technique has not been clearly established in the literature.

6.3.5 Filter Performance

A summary of the performance of selected intermittent sand filters treating household wastewaters appears in Table 6-4, 6-5, and 6-6. These tables illustrate that intermittent filters produce high-quality effluents with respect to BOD₅ and suspended solids. Normally, nitrogen is transformed almost completely to the nitrate form provided the filter remains aerobic. Rates of nitrification may decrease in winter months as temperatures fall. Little or no denitrification should occur in properly operated intermittent filters.

Total and ortho-phosphate concentrations can be reduced up to approximately 50% in clean sand; but the exchange capacity of most of the sand as well as phosphorus removal after maturation is low. Use of calcareous sand or other high-aluminum or iron materials intermixed within the sand may produce significant phosphorus removal. Chowdhry (28) and Brandes, et al. (23), reported phosphorus removals of up to 90% when additions of 4% "red mud" (high in Al₂O₃ and Fe₂O₃) were made to a medium sand. Intermittent filters are capable of reducing total and fecal coliforms by 2 to 4 logs, producing effluent values ranging from 100 to 3,000 per 100 ml and 1,000 to 100,000/100 ml for fecal and total coliforms, respectively (2)(19)(28).

6.3.6 Design Criteria

6.3.6.1 Buried Filters

Table 6-7 summarizes design criteria for subsurface intermittent sand filters.

Hydraulic loading of these filters is normally equal to or less than 1.0 gpd/ft² (0.04 m³/m²/d) for full-time residences. This value is similar to loading rates for absorption systems in sandy soils after

TABLE 6-4

PERFORMANCE OF BURIED INTERMITTENT FILTERS - SEPTIC TANK EFFLUENT

<u>Effective Size</u>	<u>Filter Characteristics</u>			<u>Effluent Characteristics</u>				<u>Reference</u>
	<u>Uniformity Coefficient</u>	<u>Hydraulic Loading</u>	<u>Depth</u>	<u>BOD</u>	<u>SS</u>	<u>NH³N</u>	<u>NO³N</u>	
mm		gpd/ft ²	in.	mg/l	mg/l	mg/l	mg/l	
0.24	3.9	1	30	2.0	4.4	0.3	25	25
0.30	4.1	1	30	4.7	3.9	3.8	23	25
0.60	2.7	1	30	3.8	4.3	3.1	27	25
1.0	2.1	1	30	4.3	4.9	3.7	24	25
2.5	1.2	1	30	8.9	12.9	6.7	18	25
0.17	11.8	0.2	39	1.8	11.0	1.0	32	22
0.23 - 0.36	2.6 - 6.1	1.15	24	4	12	0.7	17	19

TABLE 6-5

PERFORMANCE OF FREE ACCESS INTERMITTENT FILTERS

Source	Filter Characteristics			Depth in.	Dose Freq. per day	Effluent Quality				Filter Run months	Ref.
	Effective Size mm	Unif. Coeff.	Hydraulic loading gpd/ft ²			BOD mg/l	SS mg/l	NH ₃ N mg/l	NO ₃ N mg/l		
Septic Tank	0.23 - 0.26	-	4.5	60	-	23 ^a	-	8	32	6 - g ^b	21
Septic Tank	0.41	-	2.3	60	-	11 ^a	-	3	46	6 - g ^b	21
Trick. Filter	0.27	-	11.4	60	-	17 ^a	-	2	29	6 ^b	21
Trick. Filter	0.41	-	14.0	60	-	18 ^a	-	2	33	12 ^b	21
Primary	0.25	-	2.75	30	1	6	6	5	19	4.5	23
Primary	0.25	-	4.7	30	2	3	8	2	22	36	23
Primary	1.04	-	-	30	2	28	36	10	13	>54	23
Primary	1.04	-	14	30	24	4	9	3	17	>54	23
Septic Tank	0.45	3.0	5	30	3-6	8	4	3	25	3	2
Extended Aer.	0.19	3.3	3.8	30	3-6	3	9	0.3	34	12	2
Lagoon (Summer)	0.19	9.7	9.1	36	1	2	3	0.5	4.0	1	13
Lagoon (Winter)	0.19	9.7	9.1	36	1	9.4	9.6	4.6	1.0	4	13

^a Estimated from "oxygen consumed."

^b Weekly raking 3 inches deep.

TABLE 6-6
PERFORMANCE OF RECIRCULATING INTERMITTENT FILTERS^a

<u>Filter Characteristics</u>				<u>Recirculation Ratio</u>	<u>Dose</u>	<u>Effluent Quality</u>			<u>Mtnce.</u>	<u>Ref</u>
<u>Effective Size</u> mm	<u>Unif. Coeff.</u>	<u>Hydraulic Loading</u> gpd/ft ²	<u>Depth</u> in.			<u>BOD</u> mg/l	<u>SS</u> mg/l	<u>NH₃N</u> mg/l		
0.6 - 1.0	2.5	-	36	4:1	5-10 min every 30 min	4	5	-	Weed/Rake as Req'd	24
0.3 - 1.5	3.5	3.0 - 5.0 ^b	24	3:1 - 5:1	20 min every 2-3 hr	15.8 ^c	10.0 ^c	8.4 ^c	Rake Weekly	26
1.2	2.0	3.0 ^b	36	4:1	5 min every 30 min	4	3	-	Weed as Req'd	27

a Septic tank effluent.

b Based on forward flow.

c Average for 12 installations (household flow to 6,500 gpd plant).

TABLE 6-7

DESIGN CRITERIA FOR BURIED INTERMITTENT FILTERS

<u>Item</u>	<u>Design Criteria</u>
Pretreatment	Minimum level - sedimentation (septic tank or equivalent)
Hydraulic Loading	
All year	<1.0 gpd/ft ²
Seasonal	<2.0 gpd/ft ²
Media	
Material	Washed durable granular material (less than 1 percent organic matter by weight)
Effective size	0.50 to 1.00 mm
Unif. Coeff.	<4.0 (<3.5 preferable)
Depth	24 to 36 inches
Underdrains	
Material	Open joint or perforated pipe
Slope	0.5 to 1.0 percent
Bedding	Washed durable gravel OR crushed stone (1/4 to 1-1/2 in.)
Venting	Upstream end
Distribution	
Material	Open joint or perforated pipe
Bedding	Washed durable gravel or stone (3/4 to 2-1/2 in.)
Venting	Downstream end
Dosing	Flood filter; frequency greater than 2 per day

equilibrium conditions are obtained. When filters are designed for facilities with seasonal occupation, hydraulic loading may be increased to 2.0 gpd/ft² (0.08 m³/m²/d) since sufficient time will be available for drying and restoring the infiltrative surface of the bed.

The effective size of media for subsurface filters ranges from 0.35 to 1.0 mm with a UC less than 4.0, and preferably less than 3.5. Finer media will tend to clog more readily, whereas coarser media may result in poorer distribution and will normally produce a lower effluent quality.

Distribution and underdrains are normally perforated or open-joint pipe with a minimum 4-in. (10-cm) diameter. The distribution and underdrain lines are surrounded by at least 8 in. of washed durable gravel or crushed stone. For distribution lines, the gravel or stone is usually smaller than 2-1/2 in. (6 cm) but larger than 3/4 in. (2 cm), whereas the size range of the gravel or stone for the underdrains is between 1-1/2 to 1/4 in. (3.8 to 0.6 cm). Slopes of underdrain pipe range from 0.5 to 1%. With dosing, there would be no requirement for slopes on distribution piping.

Proper dosing to the filter is critical to its successful performance. The dosing system is designed to flood the entire filter during the dosing cycle. A dosing frequency of greater than two times per day is recommended. Details on design and construction of dosing chamber facilities appear in Chapter 8.

6.3.6.2 Free Access Filters (Non-Recirculating)

Design criteria for free access filters are presented in Table 6-8.

Hydraulic loading to these filters depends upon media size and wastewater characteristic. Septic tank effluent may be applied at rates up to 5 gpd/ft² (0.2 m³/m²/d), whereas a higher quality pretreated wastewater may be applied at rates as high as 10 gal/d ft² (40 cm/d). Selection of hydraulic loading will also be influenced by desired filter run times (see Section 6.3.8). Higher acceptable loadings on these filters as compared to subsurface filters relates primarily to the accessibility of the filter surface for maintenance.

Media characteristics and underdrain systems for free access filters are similar to those for subsurface filters. Distribution is often provided through pipelines and directed on splash plates located at the center or corners of the sand surface. Occasionally, troughs or spray nozzles are

TABLE 6-8
DESIGN CRITERIA FOR FREE ACCESS INTERMITTENT FILTERS

<u>Item</u>	<u>Design Criteria</u>
Pretreatment	Minimum level - sedimentation (septic tank or equivalent)
Hydraulic Loading	
Septic tank feed	2.0 to 5.0 gpd/ft ²
Aerobic feed	5.0 to 10.0 gpd/ft ²
Media	
Material	Washed durable granular material (less than 1 percent organic matter by weight)
Effective size	0.35 to 1.00 mm
Unif. Coeff.	<4.0 (<3.5 preferable)
Depth	24 to 36 inches
Underdrains	
Material	Open joint or perforated pipe
Slope	0.5 to 1.0 percent
Bedding	Washed durable gravel or crushed stone (1/4 to 1-1/2 in.)
Venting	Upstream end
Distribution	Troughs on surface; splash plates at center or corners; sprinkler distribution
Dosing	Flood filter to 2 inches; frequency greater than 2 per day
Number	
Septic tank feed	Dual filters, each sized for design flow
Aerobic feed	Single filter

employed as well, and ridge and furrow application has been successful during winter operation in severe climatic conditions. Dosing of the filter should provide for flooding the bed to a depth of approximately 2 in. Dosing frequency is usually greater than two times per day. For coarser media (greater than 0.5 mm) a dosing frequency greater than 4 times per day is desirable. Design criteria for dosing chambers, pumps, and siphons are found in Chapter 8.

The properties of the wastewater applied affect the clogging characteristics of the filter and, therefore, the methods of filter maintenance. Dual filters, each designed to carry the design flow rate, may be desirable when treating septic tank effluent to allow sufficient resting after clogging (see Section 6.3.8).

6.3.6.3 Recirculating Filters

Proposed design criteria for recirculating intermittent sand filters are presented in Table 6-9 (24)(26). These free access filters employ a recirculation (dosing) tank between the pretreatment unit and filter with provision for return of filtered effluent to the recirculation tank.

Hydraulic loading ranges from 3 to 5 gpd/ft² (0.12 to 0.20 m³/m²/d) depending on media size. Media size range is from 0.3 to 1.5 mm, the coarser sizes being recommended (23)(26). Underdrain and distribution arrangements are similar to those for free access filters. Recirculation is critical to effective operation, and a 3:1 to 5:1 recirculation ratio (Recycle: Forward Flow) is preferable. Pumps should be set by timer to dose approximately 5 to 10 min per 30 min. Longer dosing cycles may be desirable for larger installations - 20 min every 2 to 3 hr. Dosing should be at a rate high enough to insure flooding of the surface to greater than 2 in. (5 cm). Recirculation chambers are normally sized at 1/4 to 1/2 the volume of the septic tank.

6.3.7 Construction Features

6.3.7.1 Buried Filters

A typical plan and profile of a buried intermittent sand filter are depicted in Figure 6-5. The filter is placed within the ground with a natural topsoil cover in excess of 10 in. (25 cm) over the crown of the distribution pipes. The filter must be carefully constructed after excavation and the granular fill settled by flooding. Distribution and underdrain lines should be constructed of an acceptable material with a minimum diameter of 4 in. (10 cm). The tile is normally laid with open

TABLE 6-9
DESIGN CRITERIA FOR RECIRCULATING INTERMITTENT FILTERS

<u>Item</u>	<u>Design Criteria</u>
Pretreatment	Minimum level - sedimentation (septic tank or equivalent)
Hydraulic Loading	3.0 to 5.0 gpd/ft ² (forward flow)
Media	
Material	Washed durable granular material (less than 1 percent organic matter by weight)
Effective size	0.3 to 1.5 mm
Unif. Coeff.	<4.0 (<3.5 preferable)
Depth	24 to 36 inches
Underdrains	
Material	Open joint or perforated pipe
Slope	0.5 to 1.0 percent
Bedding	Washed durable gravel or crushed stone (1/4 to 1-1/2 in.)
Venting	Upstream end
Distribution	Troughs on surface; splash plates at center or corners; sprinkler distribution
Recirculation Ratio	3:1 to 5:1 (5:1 preferable).
Dosing	Flood filter to approx. 2 inches; pump 5 to 10 min per 30 min; empty recirculation tank in less than 20 min
Recirculation Tank	Volume equivalent to at least one day's raw wastewater flow

FIGURE 6-5

TYPICAL BURIED INTERMITTENT FILTER INSTALLATION

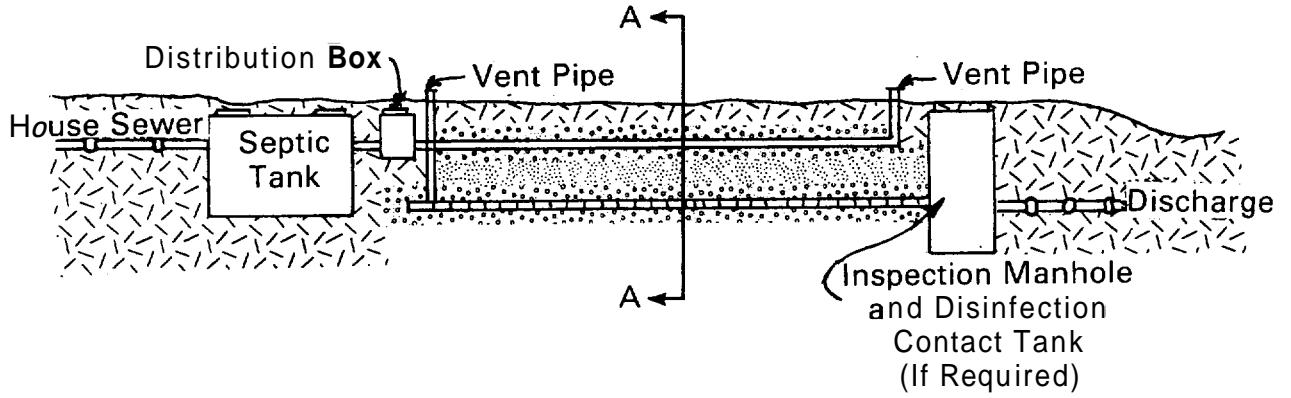

Profile

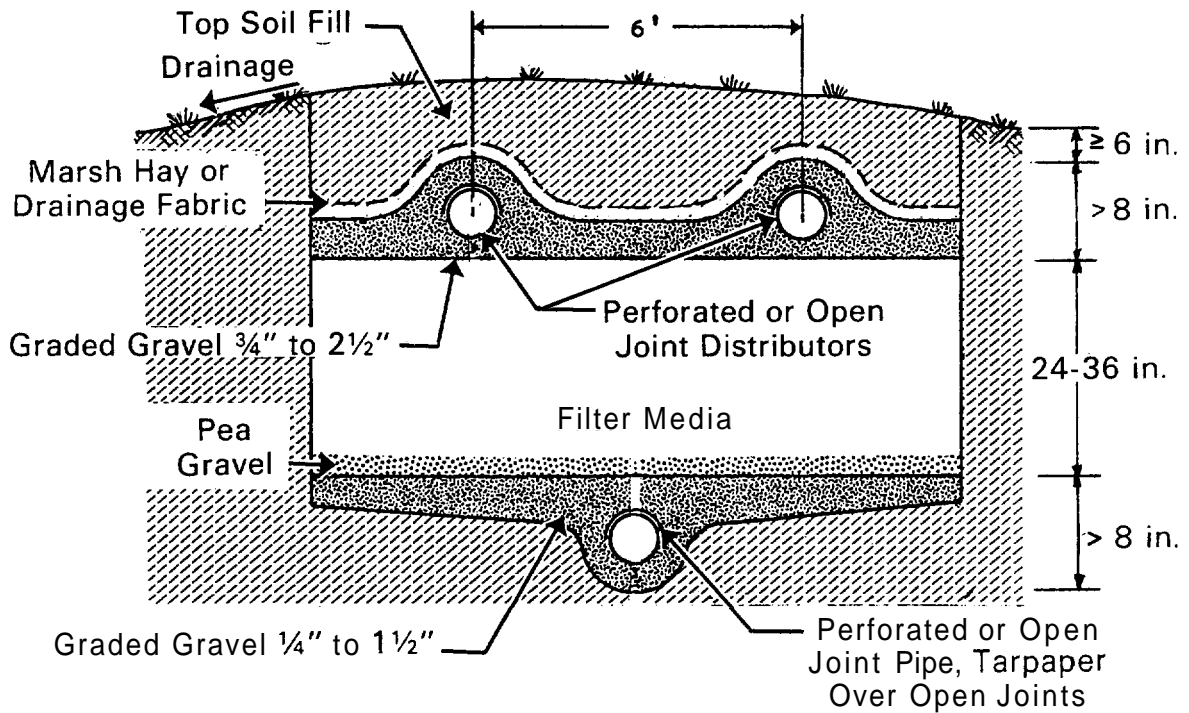

Section A-A

joints with sections spaced not less than 1/4 in. (0.6 cm) or greater than 1/2 in. (1.3 cm) apart. If continuous pipeline is used, conventional perforated pipe will provide adequate distribution and collection of wastewater within the filter.

The underdrain lines are laid to grade (0.5 to 1%) and one line is provided for each 12 ft (3.6 m) of trench width. Underdrains are provided with a vent pipe at the upstream end extending to the ground surface. The bedding material for underdrain lines is usually a minimum of 10 in. (25 cm) washed graded gravel or stone with sizes ranging from 1/4 to 1-1/2 in. (0.6 to 3.8 cm). The gravel or stone may be overlain with a minimum of 3 in. (8 cm) of washed pea gravel (1/4- to 3/8-in. [0.6 to 1.0 cm] stone) interfacing with the filter media.

The distribution lines should be level and are normally spaced at 3-ft (0.9 m) centers. Distribution lines should be vented at the downstream end with vertical risers to the ground surface. Approximately 10 in. (25 cm) of graded gravel (3/4- to 2-1/2-in. [1.9- to 6.3-cm] size) is usually employed for bedding of distribution lines. Marsh hay, washed pea gravel, or drainage fabric should be placed between the bedding material and the natural topsoil.

The finished grade over the filter should be mounded so as to provide drainage of rainfall away from the filter bed. A grade of approximately 3 to 5%, depending upon topsoil characteristics, would be sufficient.

Any washed, durable granular material that is low in organic matter may be used for filter medium. Mixtures of sand, slag, coal, or other materials have been used to enhance the removal of selected pollutants and to extend filter life. Care must be taken, however, to insure that the media does not stratify with fine layers over coarse.

Design and construction of the dosing chamber and pump or siphon employed for proper application of wastewater to the filter are described in Chapter 8 of this manual.

6.3.7.2 Free Access Filters

The plan and profile of a typical free access filter appear in Figure 6-6. These filters are often built within the natural soil, but may also be constructed completely above the ground surface. They are usually surrounded by sidewalls, often of masonry construction, to prevent earth from washing into the filter media and to confine the flow of wastewater. Where severe climates are encountered, filter walls should

FIGURE 6-6

TYPICAL FREE ACCESS INTERMITTENT FILTER

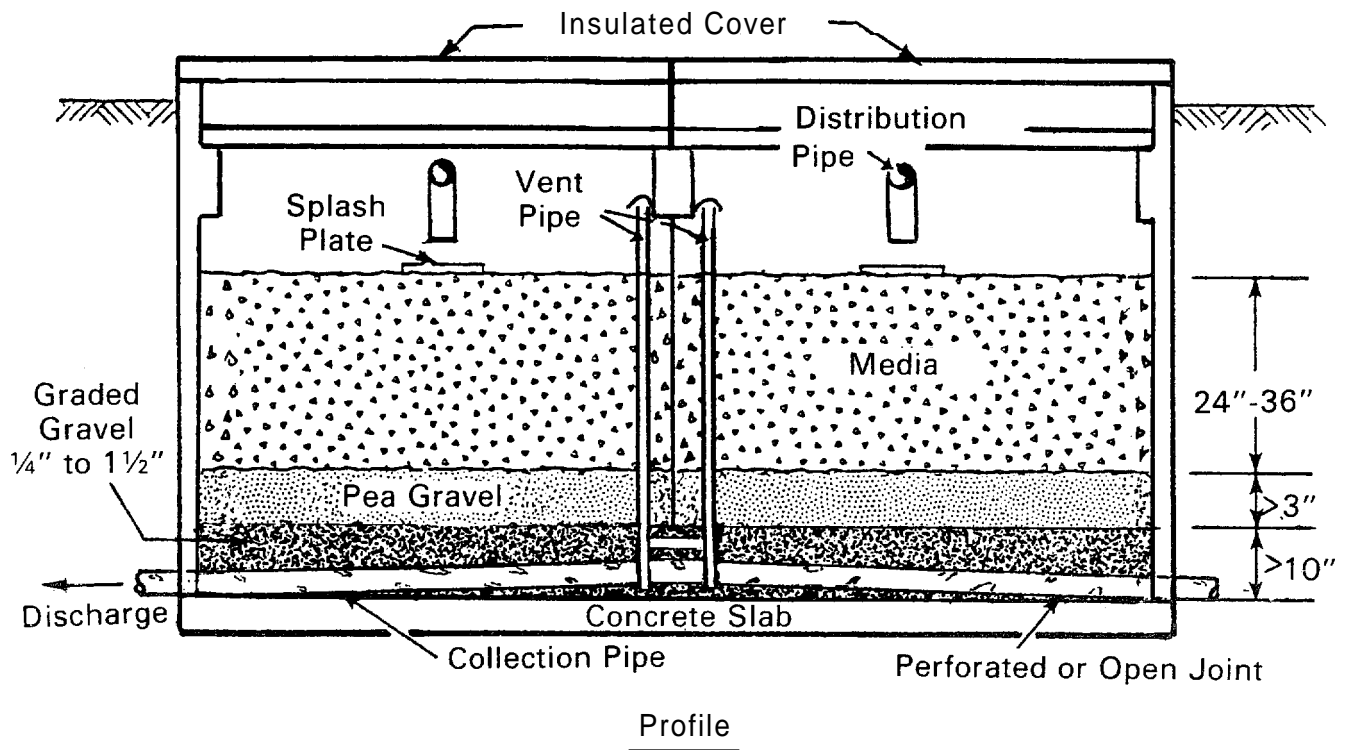
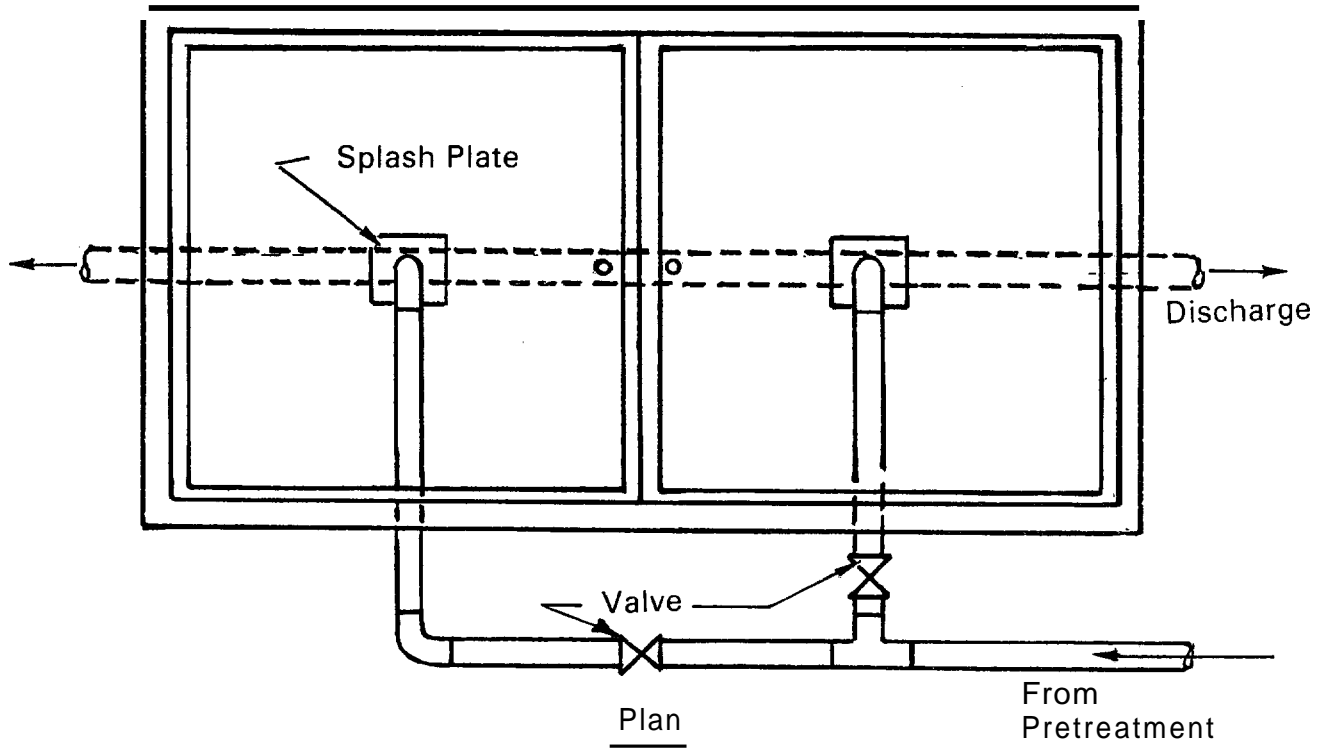

be insulated if exposed directly to the air. The floor of the filter is often constructed of poured concrete or other masonry, but may consist of the natural compacted soil. It is usually sloped to a slight grade so that effluent can be collected into open joint or perforated underdrains.

Free access filters may be covered to protect against severe weather conditions, and to avoid encroachment of weeds or animals. The cover also serves to reduce odor conditions. Covers may be constructed of treated wooden planks, galvanized metal, or other suitable material. Screens or hardware cloth mounted on wooden frames may also serve to protect filter surfaces. Where weather conditions dictate, covers should be insulated. A space of 12 to 24 in. (30 to 61 cm) should be allowed between the insulated cover and sand surface.

The underdrain lines should be constructed of an acceptable material with a minimum diameter of 4 in. (10 cm). The tile is normally laid so that joints are spaced not less than 1/4 in. (0.6 cm) or greater than 1/2 in. (1.3 cm) apart. Conventional perforated pipe may also be employed for distribution and collection. The underdrain lines may be laid directly on the filter floor, which should be slightly pitched to carry filtered effluent to the drain line. In shallow filters, the drain line may be laid within a shallow trench within the filter floor. Drain lines are normally spaced at 12-ft (3.6-m) centers and sloped at approximately 0.5 to 1% grade to discharge. The upstream end of each drain line should be vented with a vertical vent pipe above the filter surface, but within the covered space.

The bedding material for underdrain lines should be a minimum of 10 in. (25 cm) of washed graded gravel or stone with sizes ranging from 1/4 to 1-1/2 in. (0.6 to 3.8 cm). The gravel or stone may be overlain with a minimum of 3 in. (8 cm) of washed pea gravel interfacing with the filter media.

Distribution to the filter may be by means of troughs laid on the surface, pipelines discharging to splash plates located at the center or corners of the filter, or spray distributors. Care must be taken to insure that lines discharging directly to the filter surface do not erode the sand surface. The use of curbs around the splash plates or large stones placed around the periphery of the plates will reduce scour. A layer of washed pea gravel placed over the filter media may also be employed to avoid surface erosion. This practice will create maintenance difficulties; however, when it is time to rake or remove a portion of the media surface.

Filter media employed in free access filters may be any washed, durable granular material free of organic matter. As indicated previously for buried filters, mixtures of sand, slag, coal, or other materials may be employed, but with caution.

The design and construction features of the dosing chamber and pumps, or siphon systems for these filters, are described in Chapter 8.

6.3.7.3 Recirculating Filters

A profile of a typical recirculating intermittent sand filter is presented in Figure 6-7. Recirculating filters are normally constructed with free access to the filter surface. The elements of filter construction are identical to those for the free access filter (Section 6.3.6.3 above). A schematic of a recirculation tank is presented in Figure 6-8.

The basic difference between the recirculating filter and the free access filter is the recirculation chamber (dosing chamber) which incorporates a pump to recycle filter effluent. The recirculation tank receives the overflow from a septic tank, as well as a portion of sand filter effluent. A pump, controlled by a time clock mechanism, pumps the wastewater mixture to the filter surface. The recirculation tank is of equivalent strength and material to the septic tank. It is normally 1/4 to 1/2 the size of the septic tank (or a volume equivalent to at least one day's volume of raw wastewater flow). The tank must be accessible for maintenance of pumps, timers, and control valves. Covers should be provided and insulated as required by climatic conditions.

Recirculation ratios may be controlled by a variety of methods. These include splitter boxes, moveable gates, check valves, and a unique "float valve" arrangement (Figure 6-9). The "float valve" incorporates a simple tee and a rubber ball suspended in a wire basket. The ball will float up and close off the inverted tee when the water level rises. Recirculation ratios are normally established between 3:1 to 5:1 (26).

Recirculation pumps are normally submersible pumps rated for 1/3 horsepower. They should be sized to empty the recirculation tank in less than 20 min. The recirculation pump should be controlled by a time clock to operate between 5 to 10 min every 30 min (26), and should be equipped with a float shut-off and high water override. Details on pump and control specifications may be found in Chapter 8.

FIGURE 6-7
 TYPICAL RECIRCULATING INTERMITTENT FILTER SYSTEM

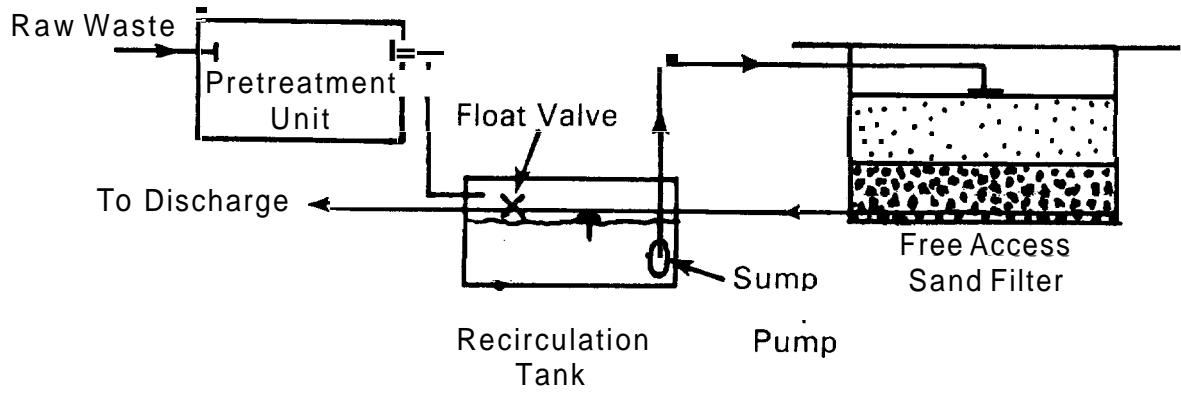

FIGURE 6-8
 RECIRCULATION TANK

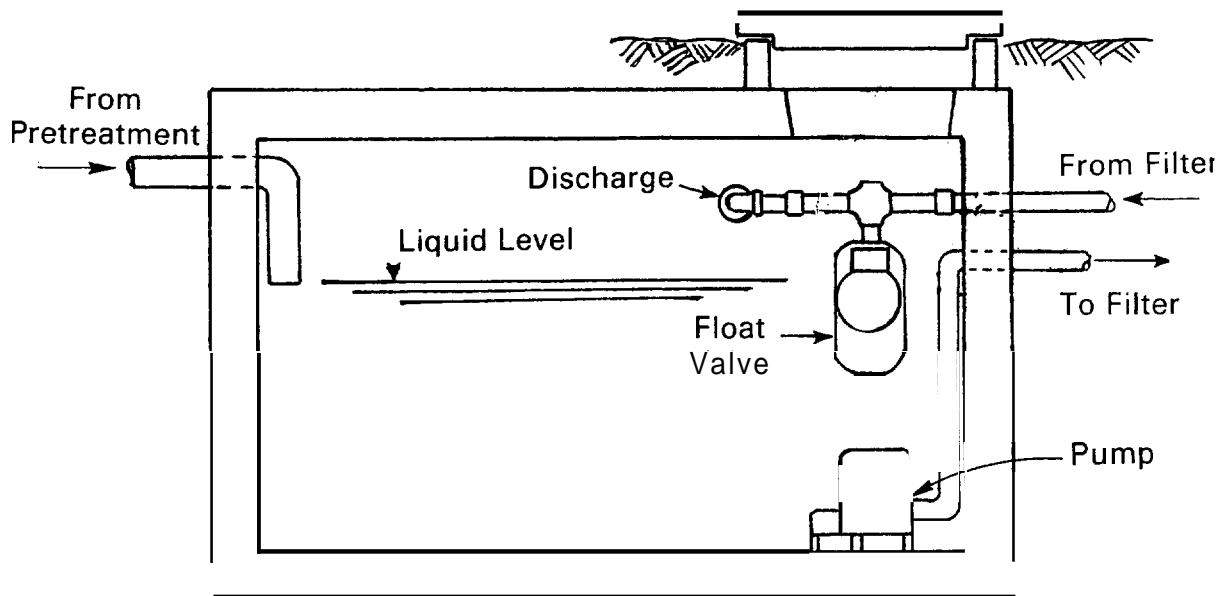
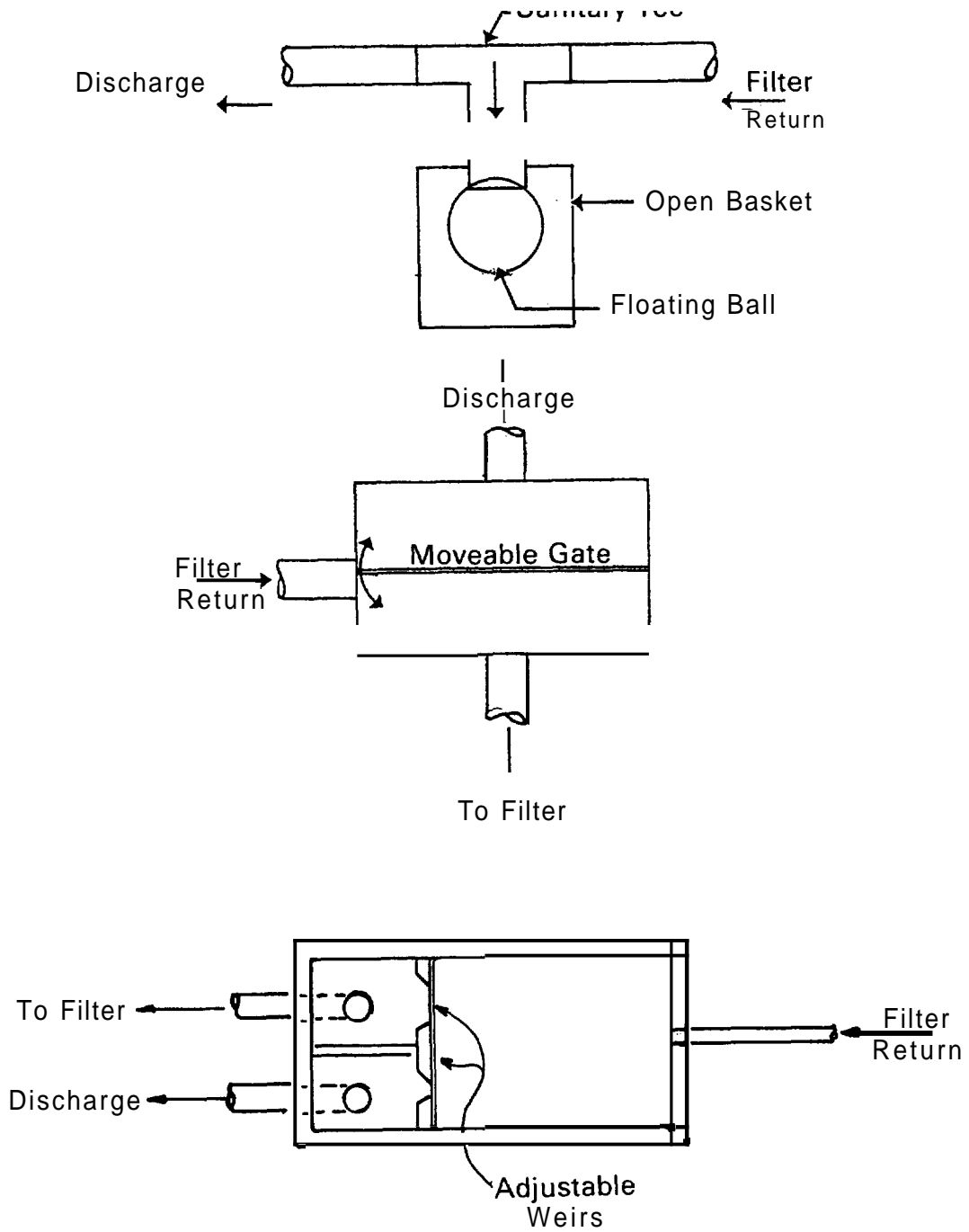

FIGURE 6-9

BY-PASS ALTERNATIVES FOR RECIRCULATING FILTERS



6.3.8 Operation and Maintenance

6.3.8.1 General

Intermittent sand filters require relatively little operational control or maintenance. Once wastewater is applied to the filter, it takes from a few days to two weeks before the sand has matured (2)(28). BOD and SS concentrations in the effluent will normally drop rapidly after maturation. Depending upon media size, rate of application, and ambient temperature, nitrification may take from 2 weeks up to 6 months to develop. Winter start-up should be avoided since the biological growth on the filter media may not properly develop (14).

As discussed above, clogging of the filter eventually occurs as the pore space between the media grains begins to fill with inert and biological materials. Once hydraulic conductivity falls below the average hydraulic loading, permanent ponding occurs. Although effluent quality may not initially suffer, anaerobic conditions within the filter result in further rapid clogging and a cessation of nitrification. Application of wastewater to the filter should be discontinued when continuous ponding occurs at levels in excess of 12 in. (30 cm) above the sand surface. A high water alarm located 12 in. (30 cm) above the sand surface serves to notify the owner of a ponded condition.

Since buried filters cannot be easily serviced, the media size is normally large and hydraulic application rates are low (usually less than 2 in./d [5 cm/d]). Proper pretreatment maintenance is of paramount importance. Free access filters, on the other hand, may be designed with finer media and at higher application rates. Experience indicates that intermittent sand filters receiving septic tank influent will clog in approximately 30 and 150 days for effective sizes of 0.2 mm and 0.6 mm, respectively (2). Aerobically treated effluent can be applied at the same rates for up to 12 months if suspended solids are under 50 mg/l (2)(23). Results with recirculated filters using coarse media (1.0 - 1.5 mm) indicate filter runs in excess of one year (27).

6.3.8.2 Maintenance of Media

Maintenance of the media includes both routine maintenance procedures and media regeneration upon clogging. These procedures apply to free access filters only. The effectiveness of routine raking of the media surface has not been clearly established, although employed in several studies (2)(14)(21)(24). Filters open to the air require weed removal as well. Cold weather maintenance of media may require different methods of wastewater application, including ridge and furrow and continuous

flooding. These methods are designed to eliminate ice sheet development. Use of insulated covers permits trouble-free winter operation in areas with ambient temperatures as low as -40° F (2).

Eventually, filter clogging requires media regeneration. Raking of the surface will not in itself eliminate the need for more extensive rehabilitation (2)(14). The removal of the top layer of sand, as well as replacement with clean sand when sand depths are depleted to less than 24 to 30 in. (61 to 76 cm), appears to be very effective for filters clogged primarily by a surface mat. This includes filters receiving aerobically treated effluent (2). In-depth clogging, however, often prevails in many intermittent filters requiring oxidation of the clogging materials. Resting of the media for a period of time has proven to be very effective in restoring filter hydraulic conductivity (2). Hydrogen peroxide treatment may also prove to be effective, although insufficient data are available on long-term application of this oxidizing agent.

6.3.8.3 Other Maintenance Requirements

The successful operation of filters is dependent on proper maintenance of the pretreatment processes. The accumulation of scum, grease, and solid materials on the filter surface due to inadequate pretreatment results in premature filter failure. This is especially critical for buried filters. Grease traps, septic tanks, and other pretreatment processes should be routinely maintained in accordance with requirements listed in other sections of this manual.

Dosing chambers, pumps, and siphons should receive periodic maintenance checks as recommended in Chapter 8. If electronic sensing devices are employed to warn owners of filter ponding, these devices should also be periodically checked as well.

6.3.8.4 Summary

The maintenance and operational requirements for buried, free access and recirculating filters are summarized in Tables 6-10, 6-11, and 6-12. Routine maintenance requirements have not been well documented for intermittent filtration onsite, but visits should be made four times per year to check filters and their appurtenances. Based on a meager data base, unskilled manpower requirements for buried filter systems would be less than 2 man days per year for examination of dosing chamber and appurtenances and septic tank. Free access filters may require from 2 to 4 man days per year for media maintenance and replacement and examination of dosing chamber, septic tank, and appurtenances. Additional

TABLE 6-10
OPERATION AND MAINTENANCE REQUIREMENTS
FOR BURIED INTERMITTENT FILTERS

<u>Item</u>	<u>O/M Requirement</u>
Pretreatment	Depends upon process
Dosing Chamber	
Pumps and controls	Check every 3 months
Timer sequence	Check and adjust every 3 months
Appurtenances	Check every 3 months
Filter Media	None

TABLE 6-11
OPERATION AND MAINTENANCE REQUIREMENTS
FOR FREE ACCESS INTERMITTENT FILTERS

<u>Item</u>	<u>O/M Requirement</u>
Pretreatment	Depends upon process
Dosing Chamber	
Pumps and controls	Check every 3 months
Timer sequence	Check and adjust every 3 months
Appurtenances	Check every 3 months
Filter Media	
Raking	Every 3 months, 3 in. deep
Replacement	
Septic tank feed	Replace when ponded more than 12 in. deep; replace top 2 to 3 in. sand; rest while alternate unit in operation (60 days)
Aerobic feed	Replace when ponded more than 12 in. deep; replace top 2 to 3 in. sand; return to service
Other	Weed as required Maintain distribution device as required Protect against ice sheeting Check high water alarm

time would be required by analytical technicians for effluent quality analysis as required. Power requirements would be variable, depending upon the dosing method employed, but should be less than 0.1 kWh/day. The volume of waste media from intermittent filters may amount to approximately 0.25 ft³/ft² (0.08 m³/m²) of surface area each time media must be removed.

TABLE 6-12
OPERATION AND MAINTENANCE REQUIREMENTS
FOR RECIRCULATING INTERMITTENT FILTERS

<u>Item</u>	<u>O/M Requirement</u>
Pretreatment	Depends upon process
Dosing Chamber	
Pumps and controls	Check every 3 months
Timer sequence	Check and adjust every 3 months
Appurtenances	Check every 3 months
Filter Media	
Raking	Every 3 months, 3 in. deep
Replacement	Skim sand when heavy incrustations occur; add new sand when sand depth falls below 24 in.
Other	Weed as required Maintain distribution device as required Protect against ice sheeting

6.3.9 Considerations for Multi-Home and Commercial Wastewaters

6.3.9.1 Applicability

Intermittent filtration processes have been successfully employed in larger scale installations to achieve high levels of treatment of wastewater .

6.3.9.2 Design Criteria

Intermittent filters for larger installations may be designed in accordance with similar criteria used for onsite systems (20). Submerged filters should be avoided. The biggest difficulty with larger flow units is adequate wastewater distribution. Troughs, ridge and furrow spray distributors, and multiple pipe apron systems may be used. Siphons or pumps should be employed to achieve from 2 to 4 doses per day. Filter flooding to approximately 2 in. (5 cm) should be achieved per dose.

Multiple beds are desirable instead of one large filter unit. Allowance should be made for 60-day resting periods for filters receiving septic tank effluent.

6.3.9.3 Construction Features

Construction features for large intermittent sand filters are similar to those of smaller units. Distribution and collection systems are normally more elaborate. Covering is desirable in very cold climates.

6.3.9.4 Operation and Maintenance

Day-to-day operation and maintenance of larger filter systems are minimal. Sand surfaces should be raked and leveled on a weekly basis. Distribution troughs should be kept level; pumps or siphons and controls must be periodically maintained. Unskilled manpower requirements of 10 to 15 man-hours per week may be expected for larger installations. Power requirements depend on dosing systems employed.

6.4 Aerobic Treatment Units

6.4.1 Introduction

Biological wastewater treatment processes are employed to transform dissolved and colloidal pollutants into gases, cell material, and metabolic end products. These processes may occur in the presence or absence of oxygen. In the absence of oxygen (anaerobic process), wastewater materials may be hydrolyzed and the resultant products fermented to produce a variety of alcohols, organic acids, other reduced end products, synthesized cell mass, and gases including carbon dioxide, hydrogen, and methane. Further treatment of the effluents from anaerobic processes is

normally required in order to achieve an acceptable quality for surface discharge. On the other hand, aerobic processes will generate high-quality effluents containing a variety of oxidized end products, carbon dioxide, and metabolized biomass. Figure 6-10 summarizes the basic differences in these processes.

Biological wastewater treatment is normally carried out in an open culture whereby a great variety of microorganisms exist symbiotically. The system is, therefore, very versatile in carrying out a variety of biochemical reactions in response to variations in input pollutants as well as other environmental factors.

An important feature of biological processes is the synthesis and subsequent separation of microbial cells from the treated liquid. In conventional aerobic processes, new biological growth may be expected to range from 30 to 60% of the dry weight of organic matter added to the system. As the residence time of microbial cells in the system increases, the net cell synthesis decreases, but never reaches zero due to the presence of a certain amount of inert material in the influent wastewater as well as nondegradable solids synthesized by the microbes. It is necessary, therefore, to waste these solids as they build up within the system. Yet, it is equally as important to maintain within the system an active population of microbes to carry out the desired biochemical reactions.

Aerobic biological treatment processes can be employed onsite to remove substantial amounts of BOD and suspended solids that are not removed by simple sedimentation. A secondary feature of the process is nitrification of ammonia in the waste (under appropriate conditions) and the significant reduction of pathogenic organisms.

Despite their advantageous treatment capabilities, aerobic units for onsite treatment are susceptible to upsets. Without regular supervision and maintenance, the aerobic unit may produce low-quality effluents. To avoid the problems associated with operation and maintenance, some manufacturers have incorporated various features into the design of these package units in order to reduce the need for frequent surveillance.

At least two process schemes are commercially available today for onsite application. These are: (1) suspended growth and (2) fixed growth. Each system has its own unique operational characteristics and design features, but all provide oxygen transfer to the wastewater, intimate contact between the microbes and the waste, and solids separation and removal.

FIGURE 6-10

AEROBIC AND ANAEROBIC DECOMPOSITION PRODUCTS

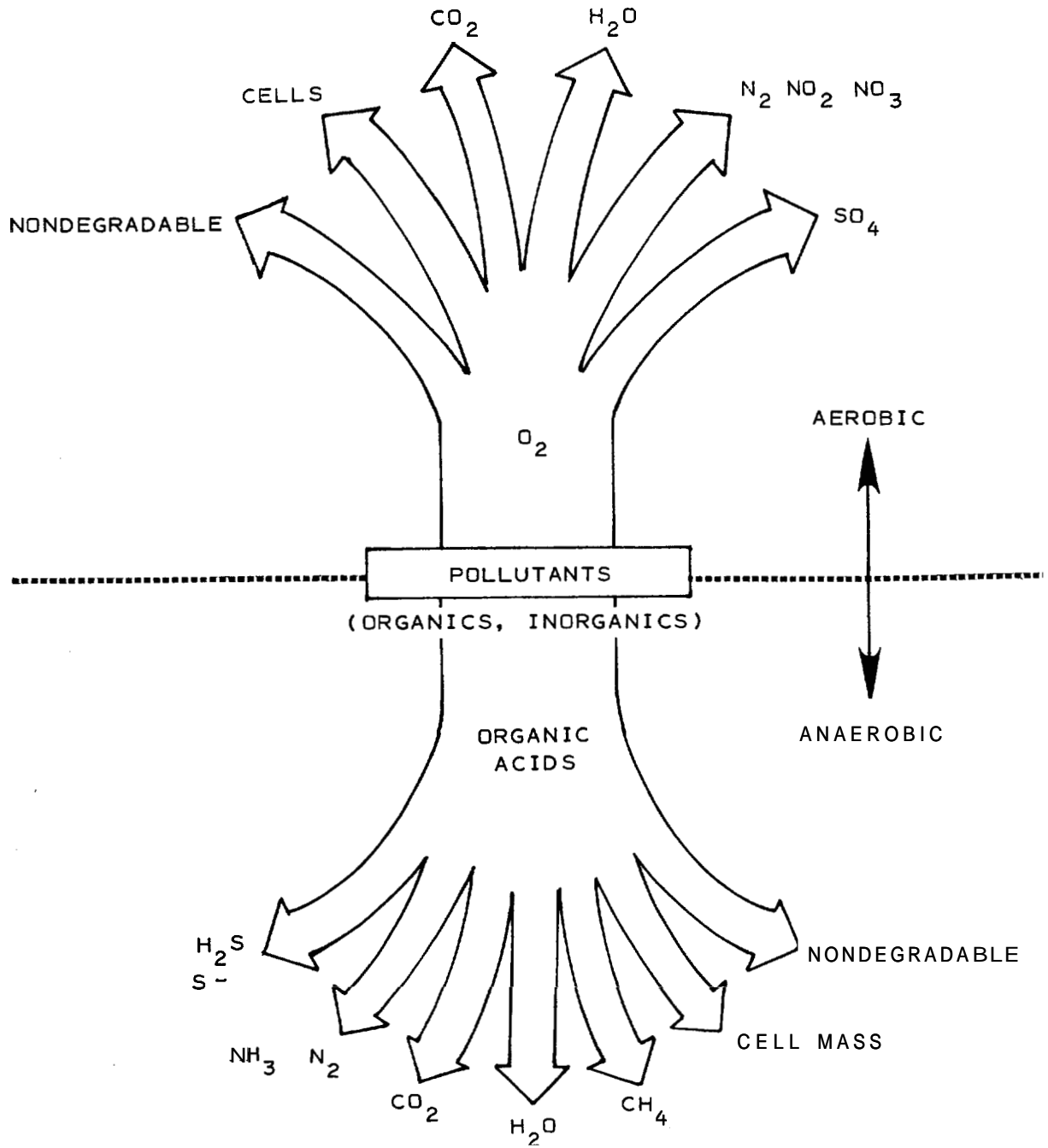

Anaerobic biological treatment processes may also be employed for onsite wastewater treatment. Septic tanks provide anaerobic treatment as discussed more fully in Section 6.2. Septic tank designs, however, do not normally incorporate considerations to optimize anaerobic decomposition. Anoxic denitrification of nitrified wastewaters may also be practiced onsite. Details of this process are described in Section 6.6. Anaerobic packed beds have been proposed for onsite treatment of wastewaters (29), but there has been no long-term field experience with these processes.

6.4.2 Suspended Growth Systems - Extended Aeration

6.4.2.1 Description

Extended aeration is a modification of the activated sludge process whereby a high concentration of microorganisms are maintained in an aeration tank, followed by separation and recycle of all or a portion of the biomass back to the aeration tank. There are a variety of proprietary extended aeration package plants available on the market today for onsite application. Figure 6-11 depicts two typical package extended aeration systems. The process may be operated in a batch or continuous flow mode, and oxygen is supplied by either diffused or mechanical aeration. Positive biomass return to the aeration tank is normally employed, but wasting of excess solids varies widely between manufactured units.

6.4.2.2 Applicability

Extended aeration processes are necessarily more complex than septic tanks, and require regular operation and maintenance. The plants may be buried or housed onsite, but must be readily accessible. The aeration system requires power, and some noise and odor may be associated with it. There are no significant physical site conditions that limit its application, although local codes may require certain set-back distances. The process is temperature-dependent^y and should be insulated and covered as climate dictates.

6.4.2.3 Factors Affecting Performance

In extended aeration package plants, long hydraulic and solids retention times (SRT) are maintained to ensure a high degree of treatment at minimum operational control, to hedge against hydraulic or organic overload to the system, and to reduce net sludge production (20). Since wasting of accumulated solids is often not routinely practiced in many of these

FIGURE 6-11

EXAMPLES OF EXTENDED AERATION PACKAGE PLANT CONFIGURATIONS

Batch - Extended Aeration

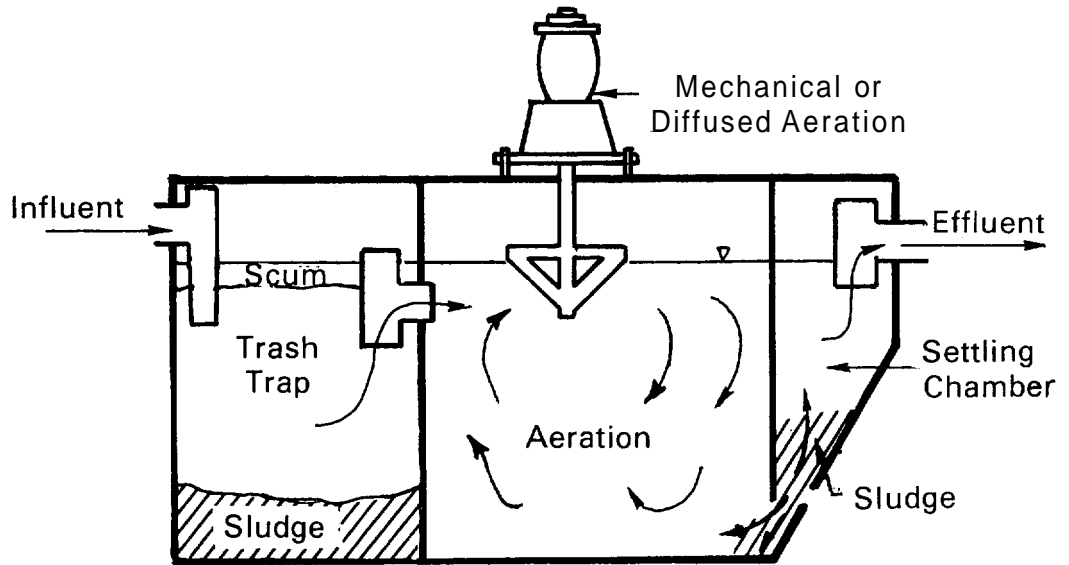
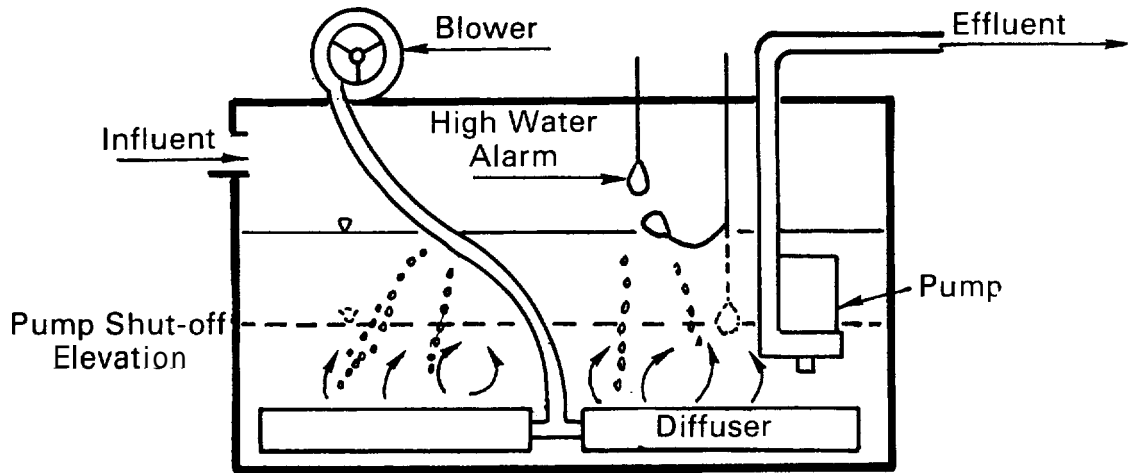

Flow-Through Extended Aeration

units, SRT increases to a point where the clarifier can no longer handle the solids, which will be uncontrollably wasted in the effluent. Treatment performance (including nitrification) normally improves with increasing hydraulic retention time and SRT to a point where excessive solids build-up will result in high suspended solids washout. This is one of the biggest operational problems with extended aeration units, and is often the reason for reports of poor performance.

Dissolved oxygen concentrations in the aeration tank should exceed 2 mg/l in order to insure a high degree of treatment and a good settling sludge. Normally, onsite extended aeration plants supply an excess of dissolved oxygen due to minimum size restrictions on blower motors or mechanical drives. An important element of most aeration systems is the mixing provided by the aeration process. Most package units provide sufficient mixing to ensure good suspension of solids and mass transfer of nutrients and oxygen to the microbes.

Wastewater characteristics may also influence performance of the process. Excess amounts of certain cleaning agents, greases, floating matter, and other detritus can cause process upsets and equipment malfunctions. Process efficiency may be affected by temperature, generally improving with increasing temperature.

The clarifier is an important part of the process. If the biomass cannot be properly separated from the treated effluent, the process has failed. Clarifier performance depends upon the settleability of the biomass, the hydraulic overflow rate, and the solids loading rate. Hydraulic surges can result in serious clarifier malfunctions. As mentioned previously, high solids loadings caused by accumulation of mixed liquor solids result in eventual solids carryover. Excessively long retention times for settled sludges in the clarifier may result in gasification and flotation of these sludges. Scum and floatable material not properly removed from the clarifier surface will greatly impair effluent quality as well.

The field performance of onsite extended aeration package systems is summarized in Table 6-13. Results presented in this summary indicate that performance is variable due to the wide diversity of factors that can adversely affect extended aeration systems. Shock loads, sludge bulking, homeowner abuse or neglect, and mechanical malfunctions are among the most common reasons for poor performance. In general, the uncontrolled loss of solids from the system is the major cause of effluent deterioration.

Generally, extended aeration plants produce a high degree of nitrification since hydraulic and solids retention times are high. Reductions of

TABLE 6-13

SUMMARY OF EFFLUENT DATA FROM VARIOUS AEROBIC UNIT FIELD STUDIES

<u>Parameter</u>	<u>Source</u>						
	<u>Ref. (2)</u>	<u>Ref. (30)</u>	<u>Ref. (31)</u>	<u>Ref. (32)</u>	<u>Ref. (33)</u>	<u>Ref. (34)</u>	<u>Ref. (35)</u>
BOD₅							
Mean, mg/l	37	37	47	92	144	31	36
Range, mg/l	<1-208	1-235	10-280	-	10-824	9-80	3-170
No. of Samples	112	167	86	146	393	10	124
Suspended Solids							
Mean, mg/l	39	62	94	94	122	49	57
Range, mg/l	3-252	1-510	18-692	-	17-768	5-164	4-366
No. of Samples	117	167	74	146	251	10	132

phosphorus are normally less than 25%. The removal of indicator bacteria in onsite extended aeration processes is highly variable and not well documented. Reported values of fecal coliforms appear to be about 2 orders of magnitude lower in extended aeration effluents than in septic tank effluents (2).

6.4.2.4 Design

A discussion of some of the important features of onsite extended aeration package plants in light of current operational experience is presented below.

a. Configuration

Most extended aeration package plants designed for individual home application range in capacity from 600 to 1,500 gal (2,270 to 5,680 l), which includes the aeration compartment, settling chamber, and in some units, a pretreatment compartment. Based upon average flows from households, this volume will provide total hydraulic retention times of several days.

b. Pretreatment

Some aerobic units provide a pretreatment step to remove gross solids (grease, trash, garbage grindings, etc.). Pretreatment devices include trash traps, septic tanks, comminutors, and aerated surge chambers. The use of a trash trap or septic tank preceding the extended aeration process reduces problems with floating debris in the final clarifier, clogging of flow lines, and plugging of pumps.

c. Flow Mode

Aerobic package plants may be designed as continuous flow or batch flow systems. The simplest continuous flow units provide no flow equalization and depend upon aeration tank volume and/or baffles to reduce the impact of hydraulic surges. Some units employ more sophisticated flow dampening devices, including air lift or float-controlled mechanical pumps to transfer the wastewater from aeration tank to clarifier. Still other units provide multiple-chambered tanks to attenuate flow. The batch (fill and draw) flow system eliminates the problem of hydraulic variation. This unit collects and treats the wastewater over a period of time (usually one day), then discharges the settled effluent by pumping at the end of the cycle.

d. Method of Aeration

Oxygen is transferred to the mixed liquor by means of diffused air, sparged turbine, or surface entrainment devices. When diffused air systems are employed, low head, blowers or compressors are used to force the air through the diffusers placed on the bottom of the tank. The sparged turbine employs both a diffused air source and external mixing, usually by means of a submerged flat-bladed turbine. The sparged turbine is more complex than the simple diffused air system. There are a variety of mechanical aeration devices employed in package plants to aerate and mix the wastewater. Air is entrained and circulated within the mixed liquor through violent agitation from mixing or pumping action.

Oxygen transfer efficiencies for these small package plants are normally low (0.2 to 1.0 lb O₂/hp hr) (3.4 to 16.9 kg O₂/MJ) as compared with large-scale systems due primarily to the high power inputs to the smaller units (constrained by minimum motor sizes for these relatively small aeration tanks) (2). Normally, there is sufficient oxygen transferred to produce high oxygen levels. In an attempt to reduce power requirements or to enhance nitrogen removal, some units employ cycled aeration periods. Care must be taken to avoid the development of poor settling biomass when cycled aeration is used.

Mixing of the aeration tank contents is also an important consideration in the design of oxygen transfer devices. Rule of thumb requirements for mixing in aeration tanks range from 0.5 to 1 hp/1,000 ft³ (13 to 26 kw/1,000 m³) depending upon reactor geometry. Commercially available package units are reported to deliver mixing inputs ranging from 0.2 to 3 hp/1,000 ft³ (5 to 79 kw/1,000 m³) (2). Deposition problems may develop in those units with the lower mixing intensities.

e. Biomass Separation

The clarifier is critical to the successful performance of the extended aeration process. A majority of the commercially available package plants provide simple gravity separation. Weir and baffle designs have not been given much attention in package units. Weir lengths of at least 12 in. (30 cm) are preferred (10,000 gpd/ft at 7 gpm) (127 m³/d/m at 0.4 l/sec) and sludge deflection baffles should be included as a part of the outlet design. The use of gas deflection barriers is a simple way to keep floating solids away from the weir area.

Upflow clarifier devices have also been employed to improve separation. Hydraulic surges must be avoided in these systems. Filtration devices

have also been employed in some units. While filters may produce high-quality effluent, they are very susceptible to both internal and external clogging. The behavior of clarifiers is dependent upon biomass settling properties, solids loading rate, and hydraulic overflow rates. Design peak hydraulic overflow rates should be less than 800 gpd/ft² (32 m³/d/m²); and at average flow design values normally range from 200 to 400 gpd/ft² (8 to 16 m³/d/m²). Solids loading rates are usually less than 30 lb/ft²/d (145 kg/m²/d) based upon average flow and less than 50 lb/ft²/d (242 kg/m²/d) based upon peak flows.

f. Biomass Return

Once separated from the treated wastewater, the biomass must be returned to the aeration tank or be wasted. Air lift pumps, draft tubes working off the aerator, and gravity return methods are normally used. Batch units and plants that employ filters do not require sludge return. Rapid removal of solids from the clarifier is desirable to avoid denitrification and subsequent floatation of solids. Positive sludge return should be employed in package plants since the use of gravity return systems has generally proved ineffective (2)(20).

Removal of floating solids from clarifiers has normally been ignored in most onsite package plant designs. Since this material results in serious deterioration of the effluent, efforts should be made to provide for positive removal of this residue. Reliance on the owner to remove floating scum is unrealistic.

g. Biomass Wasting

Most onsite package plants do not provide for routine wasting of solids from the unit. Some systems, however, do employ an additional chamber for aerobic digestion of wasted sludge. Wasting is normally a manual operation whereby the operator checks mixed liquor solids and wasted sludge when mixed liquor concentrations exceed a selected value. In general, wasting should be provided once every 8 to 12 months (2)(35).

h. Controls and Alarms

Most aerobic units are supplied with some type of alarm and control system to detect mechanical breakdown and to control the operation of electrical components. They do not normally include devices to detect effluent quality or biomass deterioration. Since the control systems

contain electrical components, they are subject to corrosion. All electrical components should be waterproofed and regularly serviced to ensure their continued operation.

6.4.2.5 Additional Construction Features

Typical onsite extended aeration package plants are constructed of noncorrosive materials, including reinforced plastics and fiberglass, coated steel, and reinforced concrete. The unit may be buried provided that there is easy access to all mechanical parts and electrical control systems, as well as appurtenances requiring maintenance such as weirs, air lift pump lines, etc. Units may also be installed above ground, but should be properly housed to protect against severe climatic conditions. Installation of the units should be in accordance with specifications of the manufacturers.

Appurtenances for the plant should be constructed of corrosion-free materials including polyethylene plastics. Air diffuser support legs are normally constructed from galvanized iron or equivalent. Large-diameter air lift units should be employed to avoid clogging problems. Mechanical units should be properly waterproofed and/or housed from the elements.

Since blowers, pumps, and other prime movers are abused by severe environment, receive little attention, and are often subject to continuous operation, they should be designed for heavy duty use. They should be easily accessible for routine maintenance and tied into an effective alarm system.

6.4.2.6 Operation and Maintenance

a. General Plant Operation

Typical operating parameters for onsite extended aeration systems are presented in Table 6-14. The activated sludge process can be operated by controlling only a few parameters - the aeration tank dissolved oxygen, the return sludge rate, and the sludge wasting rate. For onsite package plants, these control techniques are normally fixed by mechanical limitations so that very little operational control is required. Dissolved oxygen is normally high and cannot be practically controlled except by "on or off" operation. Experimentation with the process may dictate a desirable cycling arrangement employing a simple time clock

TABLE 6-14

TYPICAL OPERATING PARAMETERS FOR ONSITE EXTENDED AERATION SYSTEMS

<u>Parameter^a</u>	<u>Average</u>	<u>Maximum</u>
MLSS, mg/l	2,000-6,000	8,000
F/M, lb BOD/d/lb MLSS	0.05-0.1	-
Solids Retention Time, days	20-100	-
Hydraulic Retention Time, days	2-5	-
Dissolved Oxygen, mg/l	>2.0	-
Mixing, hp/1,000 ft ³	0.5-1.0	-
Clarifier Overflow Rate, gpd/ft ²	200-400	800
Clarifier Solids Loading, lb/d/ft ²	20-30	50
Clarifier Weir Loading, gpd/ft ²	10,000-30,000	30,000
Sludge Wasting, months	8-12	-

^a Pretreatment: Trash trap or septic tank.
Sludge Return and Scum Removal: Positive.

control that results in power savings and may also achieve some nitrogen removal (Section 6.6).

The return sludge rate is normally fixed by pumping capacity and pipe arrangements. Return sludge pumping rates often range from 50 to 200% of forward flow. They should be high enough to reduce sludge retention times in the clarifier to a minimum (less than 1 hr), yet low enough to discourage pumping of excessive amounts of water with the sludge. Time clock controls may be used to regulate return pumping.

Sludge wasting is manually accomplished in most package plants. Through experience, the operator knows when mixed liquor solids concentrations become excessive, resulting in excessive clarifier loading. Usually 8- to 12-month intervals between wasting is satisfactory, but this varies with plant design and wastewater characteristic. Wasting is normally accomplished by pumping mixed liquor directly from the aeration tank. Wasting of approximately 75% of the aeration tank volume is usually satisfactory. Wasted sludge must be handled properly (see Chapter 9).

b. Start-up

Prior to actual start-up, a dry checkout should be performed to insure proper installation. Seeding of the plant with bacterial cultures is not required as they will develop within a 6- to 12-week period. Initially, large amounts of white foam may develop, but will subside as mixed liquor solids increase. During start-up, it is advisable to return sludge at a high rate. Intensive surveillance by qualified maintenance personnel is desirable during the first month of start-up.

c. Routine Operation and Maintenance

Table 6-15 itemizes suggested routine maintenance performance for onsite extended aeration package plants. The process is labor-intensive and requires semi-skilled personnel. Based upon field experience with these units, 12 to 48 man-hr per yr plus analytical services are required to insure reasonable performance. Power requirements are variable, but range between 2.5 to 10 kWh/day.

d. Operational Problems

Table 6-16 outlines an abbreviated listing of operational problems and suggested remedies for them. A detailed discussion of these problems

TABLE 6-15

SUGGESTED MAINTENANCE FOR ONSITE
EXTENDED AERATION PACKAGE PLANTS^a

<u>Item</u>	<u>Suggested Maintenance</u>
Aeration Tank	Check for foaming and uneven air distribution.
Aeration System	
Diffused air	Check air filters, seals, oil level, back pressure; perform manufacturer's required maintenance.
Mechanical	Check for vibration and overheating; check oil level, seals; perform manufacturer's required maintenance.
Clarifier	Check for floating scum; check effluent appearance; clean weirs; hose down sidewalls and appurtenance; check sludge return flow rate and adjust time sequence if required; locate sludge blanket; service mechanical equipment as required by manufacturer.
Trash Trap	Check for accumulated solids; hose down sidewalls.
Controls	Check out functions of all controls and alarms; check electrical control box.
Sludge Wasting	Pump waste solids as required.
Analytical	Measure aeration tank grab sample for DO, MLSS, pH, settleability, temperature; measure final effluent composite sample for BOD, SS, pH (N and P if required).

^a Maintenance activities should be performed about once per month.

TABLE 6-16

OPERATIONAL PROBLEMS—EXTENDED AERATION PACKAGE PLANTS

<u>Observation</u>	<u>Cause</u>	<u>Remedy</u>
Excessive local turbulence in aeration tank	Diffuser plugging Pipe breakage Excessive aeration	Remove and clean Replace as required Throttle blower
White thick billowy foam on aeration tank	Insufficient MLSS	Avoid wasting solids
Thick scummy dark tan foam on aeration tank	High MLSS	Waste solids
Dark brown/black foam and mixed liquor in aeration tank	Anaerobic conditions Aerator failure	Check aeration system, aeration tank D.O.
Billowing sludge washout in clarifier	Hydraulic or solids overload	Waste sludge; check flow to unit
	Bulking sludge	See reference (137)
Clumps of rising sludge in clarifier	Denitrification	Increase sludge return rate to decrease sludge retention time in clarifier
	Septic conditions in clarifier	Increase return rate
Fine dispersed floc over weir, turbid effluent	Turbulence in aeration tank	Reduce power input
	Sludge age too high	Waste sludge

for larger, centralized systems can be found in the "Manual of Practice - Operation of Wastewater Treatment Plants" (36) and "Process Control Manual for Aerobic Biological Wastewater Treatment Facilities" (37). Major mechanical maintenance problems for onsite treatment units are with blower or mechanical aerator failure, pump and pipe clogging, electrical motor failure, corrosion and/or failure of controls, and electrical malfunctions (35). Careful attention to a maintenance schedule will reduce these problems to a minimum, and will also alleviate operational problems due to the biological process upset. Emphasis should be placed on adequate maintenance checks during the first 2 or 3 months of operation.

6.4.2.7 Considerations for Multi-Home Application

The extended aeration process may be well suited for multiple-home or commercial applications. The same requirements listed for single onsite systems generally apply to the larger scale systems (20) (36)(37)(38). However, larger package plant systems may be more complex and require a greater degree of operator attention.

6.4.3 Fixed Film Systems

6.4.3.1 Description

Fixed film systems employ an inert media to which microorganisms may become attached. The wastewater comes in contact with this fixed film of microorganisms either by pumping the water past the media or by moving the media past the wastewater to be treated. Oxygen may be supplied by natural ventilation or by mechanical or diffused aeration within the wastewater. Fixed film reactors are normally constructed as packed towers or as rotating plates. Figure 6-12 depicts three types of onsite fixed film systems - the trickling filter (gravity flow of wastewater downward), the upflow filter (wastewater pumped upward through the media), and the rotating biological contractor.

The trickling filter has been used to treat wastewater for many years. Modern filters today consist of towers of media constructed from a variety of plastics, stone, or redwood laths into a number of shapes (honeycomb blocks, rings, cylinders, etc.). Wastewater is distributed over the surface of the media and collected at the bottom through an underdrain system. Oxygen is normally transferred by natural drafting, although some units employ blowers. Treated effluent is settled prior to being discharged or partially recycled back through the filter.

FIGURE 6-12

EXAMPLES OF FIXED FILM PACKAGE PLANT CONFIGURATIONS

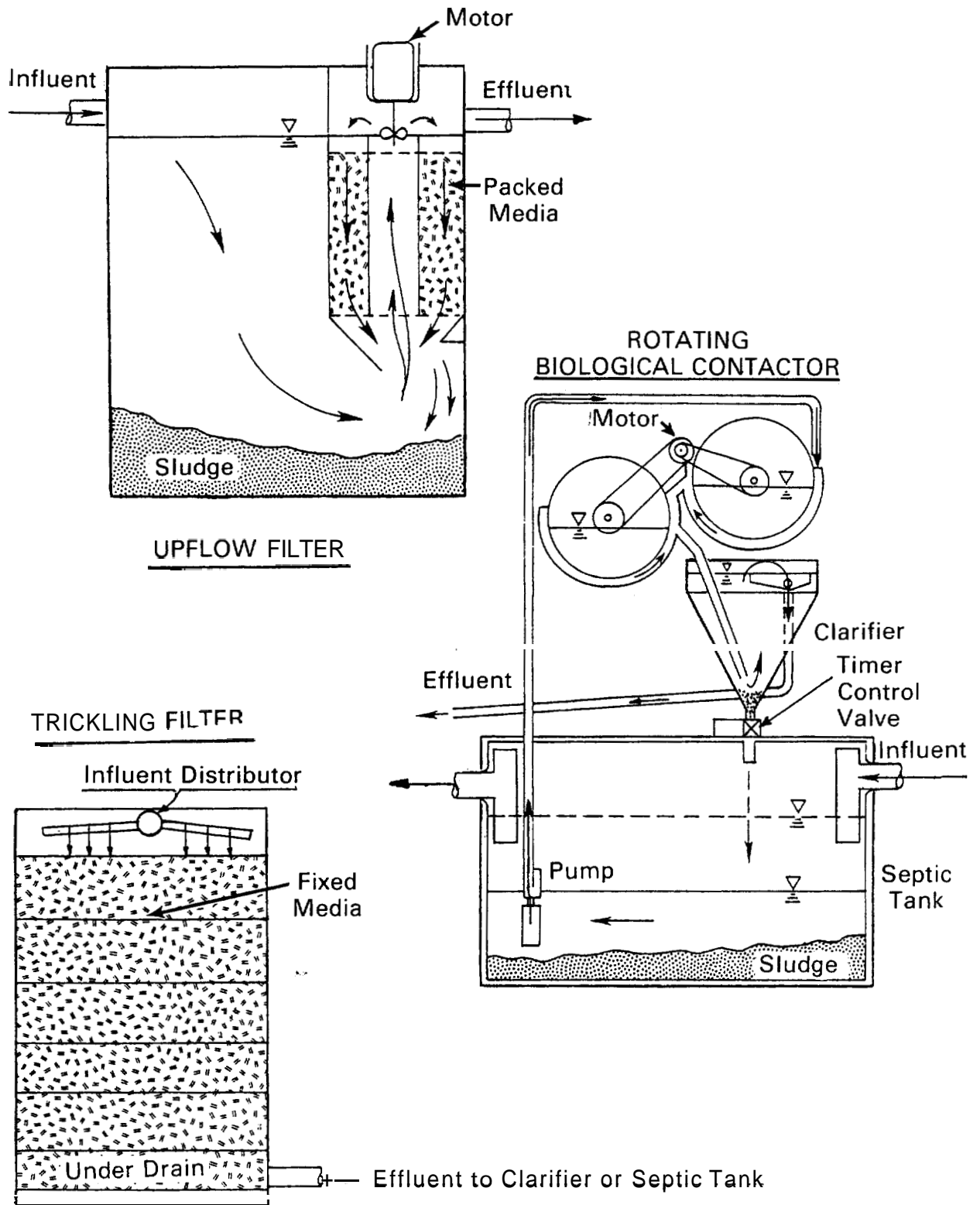

In an upflow filter, wastewater flows through the media and is subsequently collected at an overflow weir. Oxygen may be transferred to the biomass by means of diffusers located at the bottom of the tower or by surface entrainment devices at the top. One of the commercially available units of this type (built primarily for shipboard use) does not require effluent sedimentation prior to discharge (Figure 6-12). Circulation of wastewater through this particular unit promotes the shear of biomass from the media and subsequent carriage to the tank bottom.

The rotating biological contactor (RBC) employs a series of rotating discs mounted on a horizontal shaft. The partially submerged discs rotate at rates of 1 to 2 rpm through the wastewater. Oxygen is transferred to the biomass as the disc rotates from the air to the water phase. Recirculation of effluent is not normally practiced.

6.4.3.2 Applicability

There has been little long-term field experience with onsite fixed film systems. Generally, they are less complex than extended aeration systems and should require less attention; if designed properly they should produce an effluent of equivalent quality.

There are no significant physical site constraints that should limit their application, although local codes may require certain set-back distances. The process is more temperature sensitive than extended aeration and should be insulated as required. Rotating biological contactors should also be protected from sunlight to avoid excessive growth of algae which may overgrow the plate surfaces.

6.4.3.3 Factors Affecting Performance

Limited data are currently available on long-term performance of onsite fixed film systems. Detailed description of process variables that affect fixed film process performance appear in the "Manual of Practice for Wastewater Treatment Plant Design" (20). Low loaded filters should also achieve substantial nitrification, as well as good BOD and SS reductions.

6.4.3.4 Design

Onsite fixed film systems include a variety of proprietary devices. Design guidelines are, therefore, difficult to prescribe. Table 6-17

presents suggested design ranges for two generic fixed film systems, the RBC and the fixed media processes.

TABLE 6-17
TYPICAL OPERATING PARAMETERS FOR ONSITE FIXED FILM SYSTEMS

<u>Parameter^a</u>	<u>Fixed Media</u>	<u>RBC</u>
Hydraulic Loading, gpd/ft ²	25-100	0.75-1.0
Organic Loading, lb BOD/d/1000 ft ³	5-20	1.0-1.5
Dissolved Oxygen, mg/l	>2.0	>2.0
Overflow Rate, gpd/ft ²	600-800	600-800
Weir Loading, gpd/ft ²	10,000-20,000	10,000-20,000
Sludge Wasting, months	8-12	8-12

^a Pretreatment: Settling or screening.
Recirculation: Not required.

All fixed film systems should be preceded by settling and/or screening to remove materials that will otherwise cause process malfunction. Hydraulic loadings are normally constrained by biological reaction rates and mass transfer.

Organic loading is primarily dictated by oxygen transfer within the biological film. Excessive organic loads may cause anaerobic conditions resulting in odor and poor performance. Dissolved oxygen in the liquid should be at least 2 mg/l. Recirculation is not normally practiced in package fixed film systems since it adds to the degree of complexity and is energy and maintenance intensive. However, recirculation may be desirable in certain applications where minimum wetting rates are required for optimal performance.

The production of biomass on fixed film systems is similar to that for extended aeration. Very often, accumulated sludge is directed back to the septic tank for storage and partial digestion.

6.4.3.5 Construction Features

Very few commercially produced fixed film systems are currently available for onsite application. Figure 6-12 illustrates several flow arrangements that have been employed. Specific construction details are dependent on system characteristics. In general, synthetic packing or attachment media are preferred over naturally occurring materials because they are lighter, more durable, and provide better void volume - surface area characteristics. All fixed film systems should be covered and insulated as required against severe weather. Units may be installed at or below grade depending upon site topography and other adjacent treatment processes. Access to all moving parts and controls is required, and proper venting of the unit is paramount, especially if natural ventilation is being used to supply oxygen. Underdrains, where required, should be accessible and designed to provide sufficient air space during maximum hydraulic loads. Clarification equipment should include positive sludge and scum handling. All pumps, blowers, and aeration devices, if required, should be rugged, corrosion-resistant, and built for continuous duty.

6.4.3.6 Operation and Maintenance

a. General Process Operation

Fixed film systems for onsite application normally require very minimal operation. Rotating biological contactors are installed at fixed rotational speed and submergence. Flow to these units is normally fixed through the use of an integrated pumping system. Sludge wasting is normally controlled by a timer setting. Through experience, the operator may determine when clarifier sludge should be discharged in order to avoid sludge flotation (denitrification) or excessive build-up.

Where aeration is provided, it is normally designed for continuous duty. On-off cycling of aeration equipment may be practiced for energy conservation if shown not to cause a deterioration of effluent quality.

b. Routine Operation and Maintenance

Table 6-18 itemizes suggested routine maintenance performance for onsite fixed film systems. The process is less labor-intensive than extended aeration systems and requires semi-skilled personnel. Based upon very limited field experience with these units, 8 to 12 man-hr per yr plus

TABLE 6-18
 SUGGESTED MAINTENANCE FOR ONSITE
 FIXED FILM PACKAGE PLANTS^a

<u>Item</u>	<u>Suggested Maintenance</u>
Media Tank	Check media for debris accumulation, ponding, and excessive biomass - clean as required; check underdrains - clean as required; hose down sidewalls and appurtenances; check effluent distribution and pumping - clean as required.
Aeration System	See Table 6-15
RBC Unit	Lubricate motors and bearings; replace seals as required by manufacturer.
Clarifier	See Table 6-15
Trash Trap	See Table 6-15
Controls	See Table 6-15
Analytical	Measure final effluent composite sample for BOD, SS, pH (N and P if required).

^a Maintenance activities should be performed about once per month.

analytical services are required to ensure adequate performance. Power requirements depend upon the device employed, but may range from 1 to 4 kWh/day.

c. Operational Problems

Table 6-19 outlines an abbreviated list of potential operational problems and suggested remedies for onsite fixed film systems. A detailed discussion of these may be found in the "Manual of Practice - Operation of Wastewater Treatment Plants" (36) and "Process Control Manual for Aerobic Biological Wastewater Treatment Facilities" (37).

6.4.3.7 Considerations for Multi-Home Applications

Fixed film systems may be well suited for multiple-home or commercial applications. The same requirements for single-home onsite systems apply to the large-scale systems (20)(29)(37)(38). However, larger systems may be more complex and require a greater degree of operator attention.

6.5 Disinfection

6.5.1 Introduction

Disinfection of wastewaters is employed to destroy pathogenic organisms in the wastewater stream. Since disposal of wastewater to surface water may result in potential contacts between individuals and the wastewater, disinfection processes to reduce the risk of infection should be considered.

There are a number of important waterborne pathogens found in the United States (39)(40)(41)(42). Within this group of pathogens, the protozoan cyst is generally most resistant to disinfection processes, followed by the virus and, the vegetative bacteria (43). The design of the disinfection process must necessarily provide effective control of the most resistant pathogen likely to be present in the wastewater treated. Upstream processes may effectively reduce some of these pathogens, but data are scant on the magnitude of this reduction for most pathogens. Currently, the effectiveness of disinfection is measured by the use of indicator bacteria (total or fecal coliform) or disinfectant residual where applicable. Unfortunately, neither method guarantees complete destruction of the pathogen, and conservative values are often selected to hedge against this risk.

TABLE 6-19

OPERATIONAL PROBLEMS—FIXED FILM PACKAGE PLANTS

<u>Observation</u>	<u>Cause</u>	<u>Remedy</u>
Filter Ponding	Media too fine	Replace media
	Organic overload	Flush surface with high pressure stream; increase recycle rate; dose with chlorine (10-20 mg/l for 4 hours)
	Debris	Remove debris; provide pretreatment
Filter Flies	Poor wastewater distribution	Provide complete wetting of media; increase recycle rate; chlorinate (5 mg/l for 6 hours at 1 to 2 week intervals)
Odors	Poor ventilation/aeration	Check underdrains; maintain aeration equipment, if employed; insure adequate ventilation; increase recycle
Freezing	Improper insulation	Check and provide sufficient insulation
Excessive Biomass Accumulation	Organic overload	Increase recycle; flush surface with high pressure stream; dose with chlorine; increase surface area (RBC)
	Low pH; anaerobic conditions	Check venting; preaerate wastewater
Poor Clarification	Denitrification in clarifier	Remove sludge more often
	Hydraulic overload	Reduce recycle; provide flow buffering

Table 6-20 presents a listing of potential disinfectants for onsite application. Selection of the best disinfectant is dependent upon the characteristics of the disinfectant, the characteristics of the wastewater and the treatment processes preceding disinfection. The most important disinfectants for onsite application are chlorine, iodine, ozone, and ultraviolet light, since more is known about these disinfectants and equipment is available for their application.

TABLE 6-20
SELECTED POTENTIAL DISINFECTANTS FOR ONSITE APPLICATION

<u>Disinfectant</u>	<u>Formula</u>	<u>Form Used</u>	<u>Equipment</u>
Sodium Hypochlorite	NaOCl	Liquid	Metering Pump
Calcium Hypochlorite	Ca(OCl) ₂	Tablet	Tablet Contactor
Elemental Iodine	I ₂	Crystals	Crystal/Liquid Contactor
Ozone	O ₃	Gas	Generator, Gas/Liquid Contactor
Ultraviolet Light	-	Electromagnetic Radiation	Thin Film Radiation Contactor

Disinfection processes for onsite disposal must necessarily be simple and safe to operate, reliable, and economical. They normally are the terminal process in the treatment flow sheet.

6.5.2 The Halogens - Chlorine and Iodine

6.5.2.1 Description

Chlorine and iodine are powerful oxidizing agents capable of oxidizing organic matter, including organisms, at rapid rates in relatively low concentrations. Some of the characteristics of these halogens appear in Table 6-21 (20)(44)(45).

TABLE 6-21
HALOGEN PROPERTIES (27)

<u>Halogen</u>	<u>Form</u>	<u>Commercial Strength Available</u> %	<u>Specific Gravity</u>	<u>Handling Materials</u>	<u>Characteristics</u>
Sodium Hypochlorite	Liquid	12 - 15	1.14 - 1.17	Ceramic, Glass, Plastic, Rubber	Deteriorates rapidly at high temperatures, in sunlight, and at high concentrations.
Calcium Hypochlorite	Tablet (115 gm)	70		Glass, Wood, Fiberglass, Rubber	Deteriorates at 3-5%/year
Iodine	Crystals	100	4.93	Fiberglass, Some Plastics	Stable in water; solubility: 10° - 200 mg/l 20° - 290 mg/l 30° - 400 mg/l

Chlorine may be added to wastewater as a gas, Cl_2 . However, because the gas can represent a safety hazard and is highly corrosive, chlorine would normally be administered as a solid or liquid for onsite applications. Addition of either sodium or calcium hypochlorite to wastewater results in an increase in pH and produces the chlorine compounds hypochlorous acid, $HOCl$, and hypochlorite ion, OCl^- , which are designated as "free" chlorine. In wastewaters containing reduced compounds such as sulfide, ferrous iron, organic matter, and ammonia, the free chlorine rapidly reacts in nonspecific side reactions with the reduced compounds, producing chloramines, a variety of chloro-organics, and chloride. Free chlorine is the most powerful disinfectant, while chloride has virtually no disinfectant capabilities. The other chloro-compounds, often called combined chlorine, demonstrate disinfectant properties that range from moderate to weak. Measurement of "chlorine residual" detects all of these forms except chloride. The difference between the chlorine dose and the residual, called "chlorine demand," represents the consumption of chlorine by reduced materials in the wastewater (Table 6-22). Thus, in disinfection system design, it is the chlorine residual (free and combined) that is of importance in destroying pathogens.

TABLE 6-22
CHLORINE DEMAND OF SELECTED DOMESTIC WASTEWATERS^a

<u>Wastewater</u>	Chlorine Demand mg/l
Raw fresh wastewater	8 - 15
Septic tank effluent	30 - 45
Package biological treatment plant effluent	10 - 25
Sand-filtered effluent	1 - 5

^a Estimated concentration of chlorine consumed in nonspecific side reactions with 15-minute contact time.

Iodine is normally used in the elemental crystalline form, I_2 , for water and wastewater disinfection. Iodine hydrolyzes in water to form the hypiodous forms, HIO and IO^- , and iodate, IO_3^- . Normally, the predominant disinfectant species in water are I_2 , HIO , and IO^- , as little IO_3^- will be found at normal wastewater pH values (less than pH 8.0). Iodine does not appear to react very rapidly with organic compounds or ammonia in wastewaters. As with chlorine, however, most wastewaters will exhibit an iodine demand due to nonspecific side reactions. The reduced form of iodine, iodide, which is not an effective disinfectant, is not detected by iodine residual analyses.

6.5.2.2 Applicability

The halogens are probably the most practical disinfectants for use in onsite wastewater treatment applications. They are effective against waterborne pathogens, reliable, easy to apply, and are readily available.

The use of chlorine as a disinfectant may result in the production of chlorinated by-products which may be toxic to aquatic life. No toxic by-products have been identified for iodine at this time,

6.5.2.3 Performance

The performance of halogen disinfectants is dependent upon halogen residual concentration and contact time, wastewater characteristics, nature of the specific pathogen, and wastewater temperature (20). Wastewater characteristics may effect the selection of the halogen as well as the required dosage due to the nonspecific side reactions that occur (halogen demand). Chlorine demands for various wastewaters are presented in Table 6-22. The demand of wastewaters for iodine is less clear. Some investigators have reported iodine demands 7 to 10 times higher than those for chlorine in wastewaters (46)(47) while others indicate that iodine should be relatively inert to reduced compounds when compared to chlorine (48). Design of halogen systems is normally based upon dose-contact relationships since the goal of disinfection is to achieve a desired level of pathogen destruction in a reasonable length of time with the least amount of disinfectant. Because of the nonspecific side reactions that occur, it is important to distinguish between halogen dose and halogen residual after a given contact period in evaluating the disinfection process.

Table 6-23 provides a summary of halogen residual-contact time information for a variety of organisms (43). These are average values taken from a number of studies and should be used with caution. Relationships developed between disinfectant residual, contact time, and efficiency are empirical. They may be linear for certain organisms, but are often more complex. Thus, it is not necessarily true that doubling the contact time will halve the halogens residual requirements for destruction of certain pathogens. In the absence of sufficient data to make these judgements, conservative values are normally employed for residual-dose requirements.

The enteric bacteria are more sensitive to the halogens than cysts or virus. Thus, the use of indicator organisms to judge effective disinfection must be cautiously employed.

Temperature effects also vary with pathogen and halogen, and the general rule of thumb indicates that there should be a two to threefold decrease in rate of kill for every 10° C decrease in temperature within the limits of 5 to 30° C.

TABLE 6-23

PERFORMANCE OF HALOGENS AND OZONE AT 25°C [After (43)]

<u>Halogen</u>	<u>Necessary Residual After 10 Min. to Achieve 99.999% Destruction (mg/l)</u>		
	<u>Amoebic cysts</u>	<u>Enteric Bacteria</u>	<u>Enteric Virus</u>
HOC1 (Predominates @ pH,7.5)	3.5	0.02	0.4
OCL- (Predominates @ pH >7.5)	40	1.5	100
NH ₂ C1 ^a	20	4	20
I ₂ (Predominates @ pH <7.0)	3.5	0.2	15
HOI/OI ⁻ (Predominates @ 8.0 > pH > 7.0)	7	0.05	0.5
O ₃	0.3->1.8	0.2-0.3	0.2-0.3

^a NHC1₂:NH₂C1 Efficiency = 3.5:1

6.5.2.4 Design Criteria

The design of disinfection processes requires the determination of the wastewater characteristics, wastewater temperature, pathogen to be destroyed, and disinfectant to be employed (20). From this information, the required residual-concentration relationship may be developed and disinfectant dose may be calculated.

Wastewater characteristics dictate both halogen demand and the species of the disinfectant that predominates. In effluents from sand filters, chlorine demands would be low and, depending upon pH, hypochlorous acid or hypochlorite would prevail if chlorine is used. (The effluent would be almost completely nitrified, leaving little ammonia available for reaction). At pH values below 7.5, the more potent free chlorine form,

HOC1, would predominate. It is clear from Table 6-23 that pH plays an important role in the effectiveness of chlorine disinfection against virus and cysts (10 to 300 fold differences).

The effect of temperature is often ignored except to ensure that conservatively long contact times are selected for disinfection. Temperature corrections are necessary for estimating iodine doses if a saturator is employed, since the solubility of iodine in water decreases dramatically with decreased temperature.

Design of onsite wastewater disinfection systems must result in conservative dose-contact time values, since careful control of the process is not feasible. Guidelines for chlorine and iodine disinfection for on-site applications are presented in Table 6-24. These values are guidelines only, and more definitive analysis may be warranted in specific cases.

TABLE 6-24
HALOGEN DOSAGE DESIGN GUIDELINES

<u>Disinfectant</u>	<u>Dose^a</u>		
	<u>Septic Tank Effluent</u> mg/l	<u>Package Biological Process Effluent</u> mg/l	<u>Sand Filter Effluent</u> mg/l
Chlorine			
pH 6	35-50	15-30	2-10
pH 7	40-55	20-35	10-20
pH 8	50-65	30-45	20-35
Iodine ^b			
pH 6-8	300-400	90-150	10-50

a Contact time = 1 hour at average flow and 20°C; increase contact time to 2 hours at 10°C and 8 hours at 5°C for similar efficiency.

b Based upon very small data base, assuming iodine demand from 3 to 7 times that of chlorine.

The sizing of halogen feed systems is dependent upon the form of the halogen used and the method of distribution. Sample calculations are presented below.

Sample calculations:

Estimate of sodium hypochlorite dose - liquid feed

Halogen: NaOCl - trade strength 15% (150 g/l)
Dose required: 20 mg/l available chlorine
Wastewater flow: 200 gpd average

1. Available chlorine =

$$(150 \text{ g/l}) \times (3.785 \text{ l/gal}) \times (1.0 \text{ lb}/453.6 \text{ g}) = 1.25 \text{ lb/gal}$$

2. Dose required =

$$(20 \text{ mg/l}) \times (3.785 \text{ l/gal}) \times (1 \text{ lb}/453.6 \text{ g}) \times (10^{-3} \text{ g/mg}) \\ = 1.67 \times 10^{-4} \text{ lb/gal}$$

3. Dose required =

$$(1.67 \times 10^{-4} \text{ lb/gal}) \times (200 \text{ gal/d}) = 3.34 \times 10^{-2} \text{ lb/d}$$

4. NaOCl dose =

$$(3.34 \times 10^{-2} \text{ lb/d}) \div (1.25 \text{ lb/gal}) = 0.027 \text{ gal/day}$$

Estimate of halogen design - tablet feed

Halogen: Ca(OCl)_2 tablet - 115 g; commercial strength 70%
Dose Required: 20 mg/l available chlorine
Wastewater Flow: 200 gpd (750 l/d)

1. Available chlorine in tablet = $0.7 \times 115(\text{g}) = 80.5 \text{ g/tablet}$

2. Dose required = $20 \text{ (mg/l)} \times 750 \text{ (l/d)} = 15 \text{ g/d}$

3. Tablet consumption = $\frac{15 \text{ (g/d)}}{80.5 \text{ (g/tablet)}} = 0.19 \text{ tablets/day}$

or: 5.4 days/tablet

6.5.2.5 Construction Features

a. Feed Systems

There are basically three types of halogen feed systems commercially available for onsite application: stack or tablet feed systems, liquid feed systems, and saturators. Tablet feed devices for $\text{Ca}(\text{OCl})_2$ tablets (Figure 6-13) are constructed of durable, corrosion-free plastic or fiberglass, and are designed for in-line installation. Wastewater flows past the tablets of $\text{Ca}(\text{OCl})_2$, dissolving them in proportion to flow rate (depth of immersion). Tablets are added as required upon manual inspection of the unit. One commercial device provides 29-115 g/tablet per tube which would require refilling in approximately 155 days (5.4 days/tablet x 29).

Halogens may also be fed to the wastewater by an aspirator feeder or a suction feeder. The aspirator feeder operates on a simple hydraulic principle that employs the use of the vacuum created when water flows either through a venturi tube or perpendicular to a nozzle. The vacuum created draws the disinfection solution from a container into the disinfection unit, where it is mixed with wastewater passing through the unit. The mixture is then injected into the main wastewater stream. Suction feeders operate by pulling the disinfection solution from a container by suction into the disinfection unit. The suction may be created by either a pump or a siphon.

The storage reservoir containing the halogen should provide ample volume for several weeks of operation. A 1-gal (4-1) storage tank would hold sufficient 15% sodium hypochlorite solution for approximately 37 days before refill (see sample computation). A 2-gal (8-1) holding tank would supply 50 days of 10% sodium hypochlorite. A 15% sodium hypochlorite solution would deteriorate to one-half its original strength in 100 days at 25°C (49). The deterioration rate of sodium hypochlorite decreases with decreased strength; therefore, a 10% solution would decrease to one-half strength in about 220 days.

If liquid halogen is dispersed in this fashion, care must be taken to select materials of construction that are corrosion-resistant. This includes storage tanks, piping, and appurtenances as well as the pump.

Iodine is best applied to wastewater by means of a saturator whereby crystals of iodine are dissolved in carriage water subsequent to being pumped to a contact chamber (Figure 6-14). Saturators may be constructed or purchased commercially. The saturator consists of a tank of fiberglass or other durable plastic containing a supporting base medium

FIGURE 6-13

STACK FEED CHLORINATOR

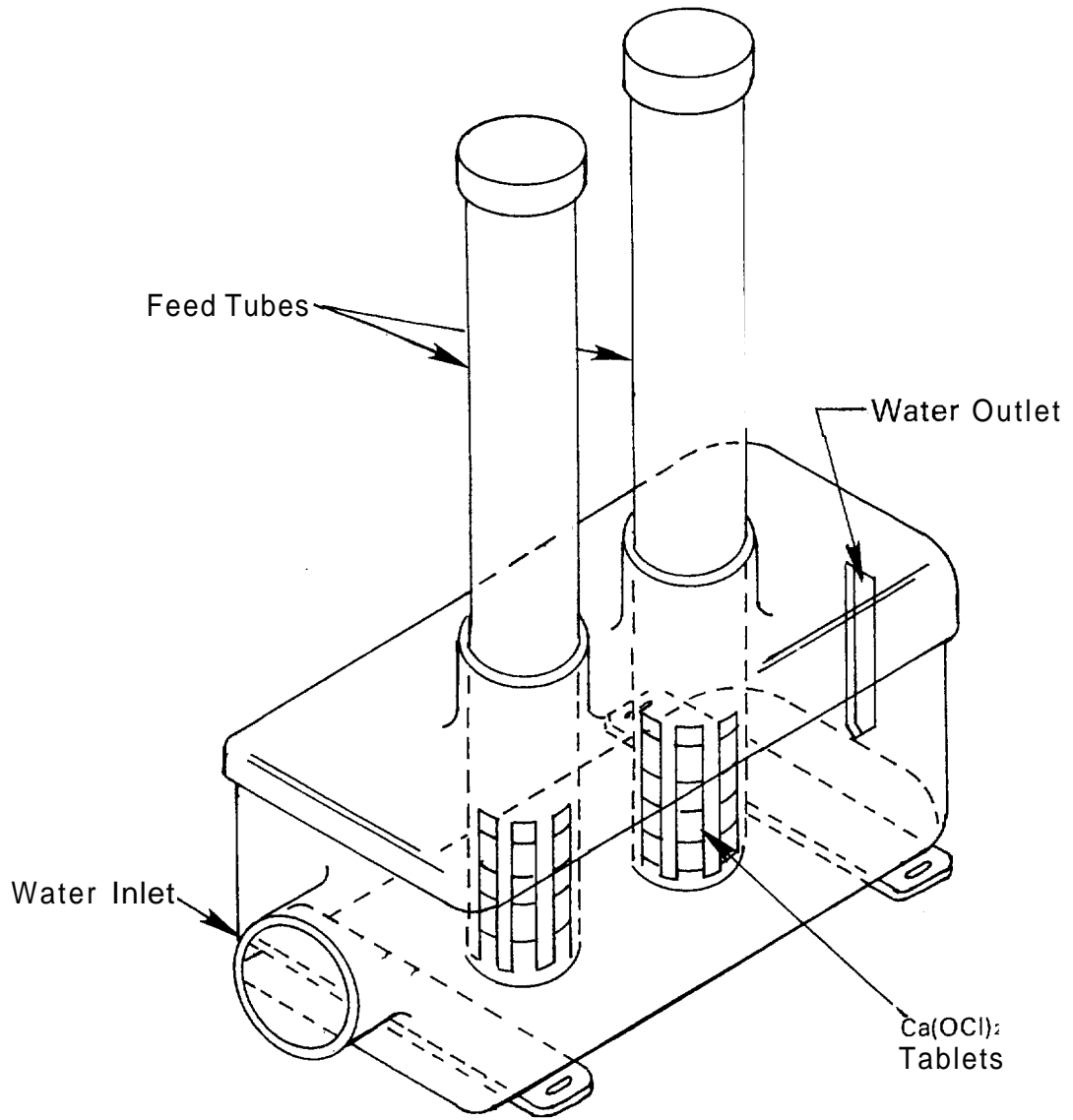
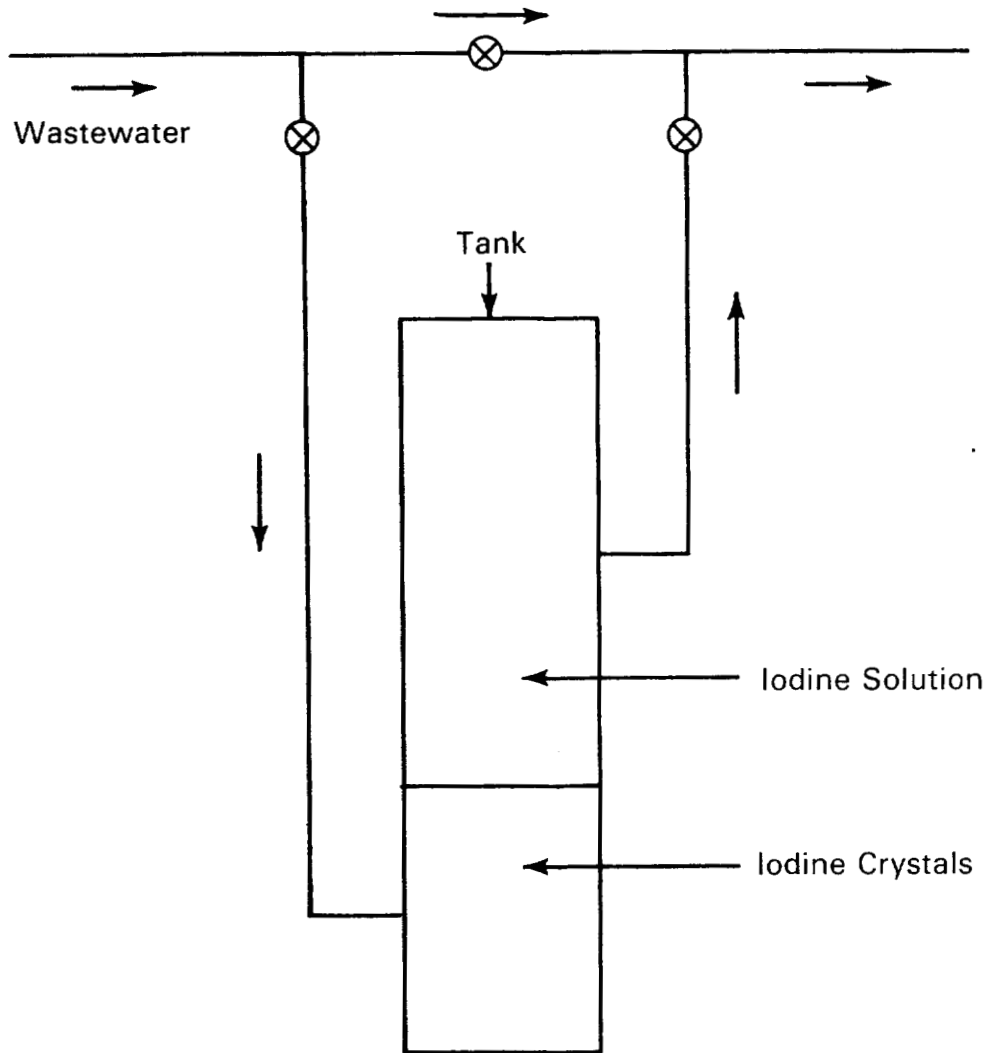

FIGURE 6-14
IODINE SATURATOR



and iodine crystals. Pretreated wastewater is split, and one stream is fed to the saturator. The dissolution of iodine is dependent upon water temperature, ranging from 200 to 400 mg/l (Table 6-21). The iodine solution from the saturator is subsequently blended with the wastewater stream, which is discharged to a contact chamber. Depending upon saturator size and dosage requirements, replenishment of iodine every 1 to 2 yr may be required (assumes a dosage of 50 mg/l for 750 l/day using a 0.2-cu-ft saturator).

b. Contact Basin

Successful disinfection depends upon the proper mixing and contact of the disinfectant with the wastewater. If good mixing is achieved, a contact time of 1 hour should be sufficient to achieve most onsite disinfection objectives when using doses presented in Table 6-24. Where flows are low (e.g., under 1,000 gal per day) (3,785 l per day), contact basins may be plastic, fiberglass, or a length of concrete pipe placed vertically and outfitted with a concrete base (Figure 6-15). A 48-in. (122-cm) diameter concrete section would theoretically provide 6 hr of wastewater detention for an average flow of 200 gal per day (757 l per day) if the water depth were only approximately 6 in. (15 cm). A 36-in. (91-cm) diameter pipe section provides 6 hr detention at approximately 12 in. (30 cm) of water depth for the same flow. Therefore, substantially longer theoretical detention times than necessary for ideal mixing conditions are provided using 36- or 48-in. (91- or 122-cm) diameter pipe. This oversizing may be practically justified for onsite applications, with low flows, since good mixing may be difficult to achieve.

Contact basins should be baffled in order to prevent serious short-circuiting within the basin. One sample baffling arrangement is illustrated in Figure 6-15.

6.5.2.6 Operation and Maintenance

The disinfection system should be designed to minimize operation and maintenance requirements, yet insure reliable treatment. Routine operation and maintenance of premixed liquid solution feed equipment consists of replacing chemicals, adjusting feed rates, and maintaining the mechanical components. Tablet feed chlorination devices should require less frequent attention, although recent experience indicates that caking of hypochlorite tablets occurs due to the moisture in the chamber. Caking may result in insufficient dosing of chlorine, but may also produce excessive dosage due to cake deterioration and subsequent spillage into the wastewater stream. Dissolution of chlorine may also be erratic, requiring routine adjustment of tablet and liquid elevation

(experience with some units indicates that dissolution rates actually increase with decreased flow rates). Routine maintenance of iodine saturators includes replacing chemicals, occasionally adjusting feed rates, redistributing iodine crystals within the saturator, and maintaining mechanical components.

FIGURE 6-15
SAMPLE CONTACT CHAMBER

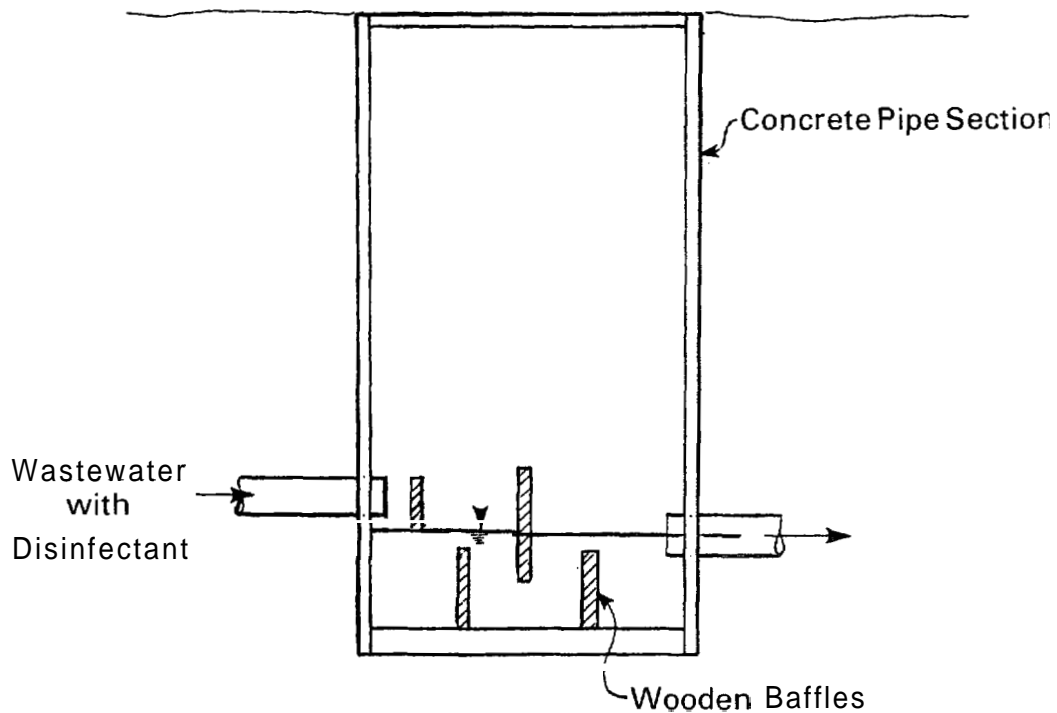

Process control is best achieved by periodic analysis of halogen residuals in the contact chamber. The halogen residuals can be measured by unskilled persons using a color comparator. Periodic bacteriological analyses of treated effluents provide actual proof of efficiency. Skilled technicians are required to sample and analyze for indicator organisms or pathogens.

It is estimated that tablet feed chlorinators could be operated with approximately 6 unskilled man-hr per yr including monthly chlorine residual analyses. Iodine saturator systems and halogen liquid feed systems may require 6 to 10 semi-skilled man-hr per yr. Electrical power consumption would be highly variable depending upon other process pumping requirements, as well as the use of metering pumps and controls. Chemical requirements will vary, but are estimated to be about 5 to 25 lb (2 to 11 kg) of iodine and 5 to 15 lb (2 to 7 kg) of available chlorine per yr for a family of four.

6.5.2.7 Other Considerations

In making a final decision on halogen disinfection, other considerations must be included in addition to cost, system effectiveness, and reliability. Without a dechlorination step, chlorine disinfection may be ruled out administratively. Currently, there is no evidence that iodine or its compounds are toxic to aquatic life.

6.5.3 Ultraviolet Irradiation

6.5.3.1 Description

The germicidal properties of ultraviolet (UV) irradiation have been recognized for many years (50)(51). UV irradiation has been used for the disinfection of water supplies here and abroad, and currently finds widest application for small water systems for homes, commercial establishments, aboard ship, and in some industrial water purification systems. The use of UV irradiation for wastewater disinfection has only recently been seriously studied (52)(53).

Ultraviolet is germicidal in the wave length range of 2,300 to 3,000 Å, its greatest efficiency being at 2,540 Å. Currently, high-intensity, low-pressure mercury vapor lamps emit a major percentage of their energy at this wave length, making them most efficient for use. The primary mode of action of UV is the denaturation of nucleic acids, making it especially effective against virus.

In order to be effective, UV energy must reach the organism to be destroyed. Unfortunately, UV energy is rapidly absorbed in water and by a variety of organic and inorganic molecules in water. Thus, the transmittance or absorbance properties of the water to be treated are critical to successful UV disinfection. To achieve disinfection, the water to be treated is normally exposed in a thin film to the UV source. This may be accomplished by enclosing the UV lamps within a chamber, and

directing flow through and around the lamps. It may also be accomplished by exposing a thin film of water flowing over a surface or weir to a bank of lamps suspended above and/or below the water surface.

The lamps are encased within a clear, high transmittance, fused quartz glass sleeve in order to protect them. This also insulates the lamps so as to maintain an optimum lamp temperature (usually about 105° F or 41° C). To ensure maintenance of a very high transmittance through the quartz glass enclosure, wipers are usually provided with this equipment. Figures 6-16 and 6-17 depict a typical UV disinfection lamp arrangement currently being used. There are a number of commercially available units that may be applicable to onsite wastewater applications.

6.5.3.2 Applicability

Site conditions should not restrict the use of UV irradiation processes for onsite application, although a power source is required. The unit must be housed to protect it from excessive heat, freezing, and dust. Wastewater characteristics limit the applicability of UV equipment since energy transmission is dependent upon the absorbance of the water to be treated. Therefore, only well-treated wastewater can be disinfected with UV.

6.5.3.3 Factors Affecting Performance

The effectiveness of UV disinfection is dependent upon UV power, contact time, liquid film thickness, wastewater absorbance, process configuration, input voltage, and temperature (50)(51)(52).

The UV power output for a lamp is dependent upon the input voltage, lamp temperature, and lamp characteristics. Typically, UV output may vary from as low as 68% of rated capacity at 90 volts to 102% at 120 volts. Lamp temperatures below and above about 104° F (40° C) also results in decreased output. The use of quartz glass enclosures normally ensures maintenance of optimum temperature within the lamp.

Since disinfection by UV requires that the UV energy reaches the organisms, a measure of wastewater absorbance is crucial to proper design. Transmissibility is calculated as an exponential function of depth of penetration and the absorption coefficient of the wastewater:

$$\tau = e^{-ad}$$

FIGURE 6-16
TYPICAL UV DISINFECTION UNIT

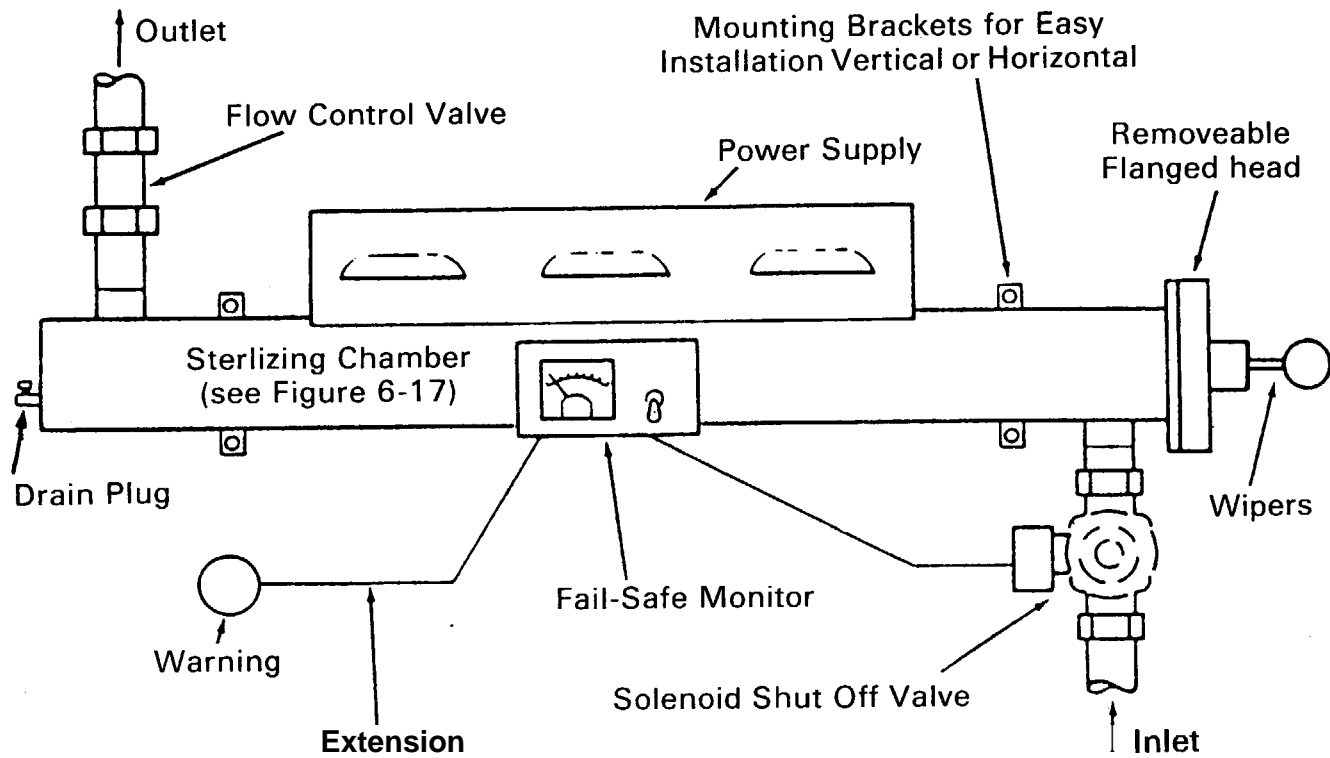
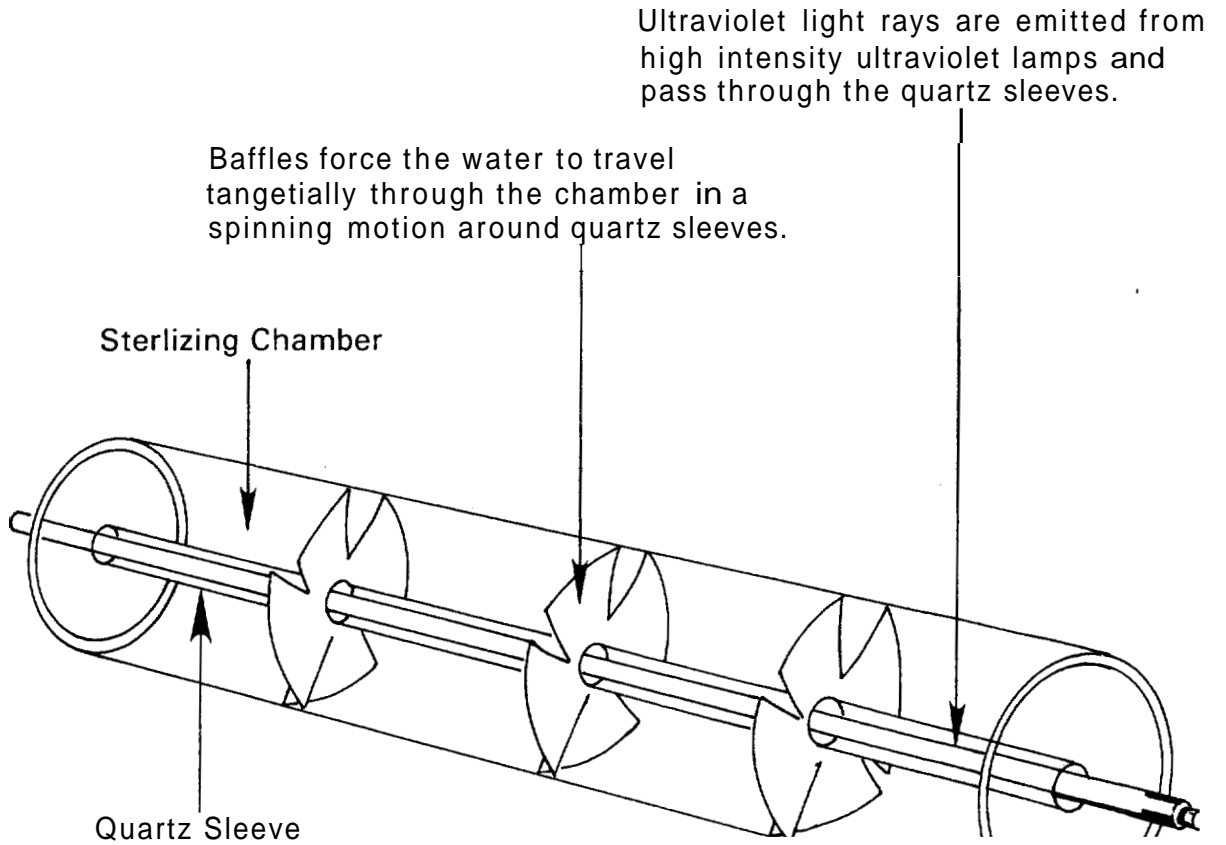

FIGURE 6-17

TYPICAL UV STERILIZING CHAMBER



Typical sterilizers employ one to twelve lamps per sterilizing chamber.

where T is the fraction transmitted, a is the absorption coefficient in cm^{-1} at 2,537 Å, and d is the depth in cm. Typically, a very high-quality distilled water will have an absorption coefficient of 0.008, where tap water would normally vary from 0.18 to 0.20. Wastewaters polished with sand filtration should produce absorption coefficients of from 0.13 to 0.20, whereas septic tank effluents may be as high as 0.5. Currently, rule of thumb requirements for UV application indicate that turbidities should be less than 10 JTU and color less than 15 mg/l. (1 Jackson Turbidity Unit [JTU] is about equivalent to 1 Formazin Turbidity Unit [FTU]).

The relationship between UV power and contact time is still uncertain. Empirical relationships have been used to express the performance of UV equipment. Currently the empirical term, microwatt seconds per square centimeter (mw sec/cm^2), is used (50)(51).

The required contact time for a given exposure is dictated by the wastewater absorbance, film thickness, and the pathogen to be destroyed. Typical values of UV dosage for selected organisms appear in Table 6-25.

This tabulation indicates that a wide spectrum of organisms are about equally sensitive to UV irradiation. There are exceptions to this, however; *Bacillus* spores require dosages in excess of 220,000 mw sec/cm^2 , and protozoan as high as 300,000 mw sec/cm^2 .

One characteristic trait of UV disinfection of water has been the photo-reevaluation of treated organisms within the wastewater. Exposure of the wastewater to sunlight following UV disinfection has produced as much as 1.5 log increase in organisms concentration. This phenomena does not always occur, however, and recent field tests indicate that photoreactivation may not be of significant concern (52).

6.5.3.4 Design

There has been little long-term experience with wastewater UV disinfection (2)(52)(53). Therefore, firm design criteria are not available. One may draw upon water supply disinfection criteria, however, for conservative design (50)(51).

TABLE 6-25

UV DOSAGE FOR SELECTED ORGANISMS

<u>Organism</u>	<u>Dosage for 99% Kill at a = 0.0</u> mw sec/cm ²
Shigella	4,000
Salmonella	6,000
Poliovirus	6,000
IH Viral Form	8,000
E. Coli	7,000
Protozoan	180-300,000 ^a
Fecal Coliform	23,000 ^b

^a For 99.9% inactivation.

^b Field studies corrected to a = 0; 99.96% inactivation.

Wastewater should be pretreated to a quality such that turbidity is less than 10 JTU and color is less than 15 mg/l. Intermittent sand filtered effluent quality will generally not exceed these limits when properly managed. It would be desirable to provide measurement of UV transmittance in the wastewater on a continuous basis to ensure that sufficient UV power reaches the organism to be treated. Dosage values should be conservative until more data are available. Therefore, a desired minimum UV dose of 16,000 mw sec/cm² or kw sec/m³ should be applied at all points throughout the disinfection chamber. A maximum depth of penetration should be limited to about 2 in. (5 cm) to allow for variation in wastewater absorption. The UV lamps should be enclosed in a quartz glass sleeve and appropriate-automatic cleaning devices should be provided. A UV intensity meter should be installed at a point of greatest water depth from the UV tubes, and an alarm provided to alert the owner when values fall below on acceptable level.

6.5.3.5 Construction Features

Commercially available UV units sold primarily for water supply disinfection are applicable for onsite wastewater disinfection. Most of these units are self-contained and employ high-intensity UV irradiation over a thin film of water for short contact times.

The self-contained unit should be installed following the last treatment process in the treatment sequence, and should be protected from dust, excessive heat, and freezing. It should be accessible for maintenance and control. As described in the previous section, the unit should be equipped with a cleaning device (manual or automatic) and an intensity meter that is properly calibrated. Flow to the unit should be maintained relatively constant. This is often achieved by means of a pressure compensated flow control valve.

Some larger UV modules are available that consist of a series of lamps encased within quartz glass enclosures. The module may be placed within the flow stream such that all water passes through the module. UV lamps positioned over discharge weirs, and therefore out of the water, are also available. These systems are not as efficient as flow through units since only a fraction of the lamp arc intercepts the water. Control of the water film over the weir plate (V-notch or sharp crested) is difficult to maintain unless upstream flows are carefully regulated. Cleaning and metering devices are required for both of these systems.

Depending on upstream processes and the UV unit employed, the UV system may be operated on a continuous flow or intermittent basis. For small flows, self-contained tubular units and intermittent flow would be employed. Influent to the unit could be pumped to the UV system from a holding tank. In order to obtain full-life expectancy of the UV lamps, they should be operated continuously regardless of flow arrangement. Where UV modules are employed, continuous flow through the contact chamber may be more practical.

6.5.3.6 Operation and Maintenance

Routine operational requirements include quartz glass enclosure cleaning, lamp replacement, and UV intensity meter reading. Since UV disinfection does not produce a residual, the only monitoring required would be periodic bacterial analyses by skilled technicians. Periodic maintenance of pumping equipment and controls, and cleaning of quartz jackets during lamp replacement, would also be required.

Cleaning of quartz glass enclosures is of paramount importance since UV transmittance is severely impaired by the accumulation of slimes on the enclosures. Cleaning is required at least 3 to 4 times per year at a minimum, and more often for systems employing intermittent flow. If automatic wipers are employed, the frequency of manual cleaning may be reduced to twice per year. Expected lives of lamps are variable, normally ranging from 7,000 to 12,500 hours. It is good practice, however, to replace lamps every 10 months, or when metered UV intensity falls below acceptable values. A complete cleaning of quartz glass enclosures with alcohol is required during lamp replacement. Based on limited operational experience, it is estimated that 10 to 12 man-hr per yr are required to maintain the UV system. Power requirements for the UV system for design flow rates up to 4 gpm (0.25 l/sec) are approximately 1.5 kWh/day.

6.5.4 Ozonation

6.5.4.1 Description

Ozone, O_3 , a pale blue gas with pungent odor, is a powerful oxidizing agent. It is only slightly soluble in water, depending upon temperature, and is highly unstable. Because of its instability, ozone must be generated on site.

Ozone is produced by the dissociation of molecular oxygen into atomic oxygen with subsequent formation of O_3 . It is produced commercially by passing an oxygen-containing feed gas between electrodes separated by an insulating material (54)(55). In the presence of a high-voltage, high-frequency discharge, ozone is generated from oxygen in the electrode gap.

Ozone is a powerful disinfectant against virus, protozoan cysts, and vegetative bacteria (54)(55)(56)(57). It is normally sparged into the water to be treated by means of a variety of mixing and contact devices. Because of its great reactivity, ozone will interact with a variety of materials in the water, resulting in an ozone demand. The short half-life of ozone also results in the rapid disappearance of an ozone residual in the treated water.

6.5.4.2 Applicability

Ozone is currently used to disinfect water supplies in the United States and Europe, and is considered an excellent candidate as an alternate wastewater disinfectant (54)(55)(56)(57). The major drawback to its

widespread use to date has been the expense of generation. There is no documented long-term field experience with ozone disinfection onsite.

Since ozone is a highly corrosive and toxic gas, its generation and use onsite must be carefully monitored and controlled. The generator requires an appropriate power source, and must be properly housed to protect it from the elements. Wastewater characteristics will have an impact on ozone disinfectant efficiency and must be considered in the evaluation of this process.

Data on the effectiveness of ozone residuals against pathogens are scant. Employing the same criteria as used for halogens, ozone appears to be more effective against virus and amoebic cysts than the halogens (Table 6-23).

The literature indicates that ozone action is not appreciably affected by pH variations between 5.0 and 8.0 (58). Turbidity above values of 5 JTU has a pronounced effect upon ozone dosage requirements, however (45)(58). Limited field experience indicates that ozone requirements may approximately double with a doubling of turbidity to achieve comparable destruction of organisms (47).

Currently, with very limited operating data, prescribed ozone applied dosages recommended for wastewater disinfection vary from 5 to 15 mg/l depending upon contactor efficiencies and pathogen to be destroyed.

6.5.4.3 Construction Features

The ozone disinfection system consists of the ozone gas generation equipment, a contactor, appropriate pumping capacity to the contactor and controls. There are two basic types of generating equipment. The tube-type unit is an air-cooled system whereby ozone is generated between steel electrode plates faced with ceramic. Oxygen-containing feed gas may be pure oxygen, oxygen-enriched air, or air. The gas is cleaned, usually through cartridge-type impingement filters, and compressed to about 10 psi. The compressed gas is subsequently cooled and then dried prior to being reacted in the ozone contacting chamber. Drying is essential to prevent serious corrosion problems within the generator.

The generated ozone-enriched air is intimately mixed with wastewater in a contacting device. Ozone contactors include simple bubble diffusers in an open tank, packed columns, and positive pressure injection (PPI) devices. Detention times within these systems range from 8-15 min in

the bubble diffuser units to 10-30 sec in packed columns and PPI systems (59)(60). Limited data are currently available on long-term use of these contactor devices for onsite systems. There are relatively few field-tested, small-capacity systems commercially available.

6.5.4.4 Operation and Maintenance

The ozone disinfection system is a complex series of mechanical and electrical units, requiring substantial maintenance, and is susceptible to a variety of malfunctions. Since data on long-term experience are relatively unavailable, it is not possible to assess maintenance requirements on air cleaning equipment, compressors, cooling and drying equipment, and contactors. It is estimated that 8 to 10 kWh/lb of ozone generated will be required (54). Monitoring requirements are similar to those for UV disinfection, including occasional bacterial analyses and routine ozone monitoring.

6.6 Nutrient Removal

6.6.1 Introduction

6.6.1.1 Objectives

Nitrogen and phosphorus may have to be removed from wastewaters under certain circumstances. Both are plant nutrients and may cause undesirable growths of plants in lakes and impoundments. Nitrogen may also create problems as a toxicant to fish (free ammonia), as well as to animals and humans (nitrates). In addition, the presence of reduced nitrogen may create a significant oxygen demand in surface waters.

Nitrogen may be found in domestic wastewaters as organic nitrogen, as ammonium, or in the oxidized form as nitrite and nitrate. The usual forms of phosphorus in domestic wastewater include orthophosphate, polyphosphate, pyrophosphate, and organic phosphate. Sources of wastewater nitrogen and phosphorus from the home are presented in Table 4-4.

The removal or transformation of nitrogen and phosphorus in wastewaters has been the subject of intensive research and demonstration over the past 15 to 20 yr. Excellent reviews of the status of these treatment processes can be found in the literature (61)(62). As discussed in Chapter 7, the soil may also serve to remove and/or transform the nitrogen and phosphorus in wastewaters percolating through them.

The treatment objective for nitrogen and phosphorus in wastewater is dependent upon the ultimate means of disposal. Surface water quality objectives may require limitations of total phosphate, organic and ammonia nitrogen, and/or total nitrogen. Subsurface water quality objectives are less well developed, but may restrict nitrate-nitrogen and/or total phosphate.

6.6.1.2 Application of Nutrient Removal Processes to Onsite Treatment

There are a number of nutrient removal processes applicable to onsite wastewater treatment, but there are very little data on long-term field applications of these systems. In-house wastewater management through segregation and household product selection appears to be the most practical and cost-effective method for nitrogen and phosphorus control onsite. Septic tanks may remove a portion of these nutrients as floatable and settleable solids. Other applicable chemical, physical, or biological processes may also be employed to achieve a given level of nutrient removal. Although these supplemental processes may be very effective in removing nutrients, they are normally complex and energy and labor intensive.

Since the state-of-the-art application of onsite nutrient removal is limited, the discussion that follows is brief. Processes that may be successful for onsite application are described. Acceptable design, construction, and operation data are presented where they are available.

6.6.2 Nitrogen Removal

6.6.2.1 Description

Table 6-26 outlines the potential onsite nitrogen control options. In many instances, these options also achieve other treatment objectives as well, and should be evaluated as to their overall performance. The removal or transformation of nitrogen within the soil absorption system is described fully in Chapter 7.

6.6.2.2 In-House Segregation

Chapter 4 provides a detailed description of the household wastewater characteristics and sources of these wastewaters. Between 78 and 90% of the nitrogen in the wastewater discharged from the home is from toilets. Separation of toilet wastewaters would result in average nitrogen levels

TABLE 6-26

POTENTIAL ONSITE NITROGEN CONTROL OPTIONS^a

<u>Option</u>	<u>Description</u>	<u>Effectiveness</u>	<u>Comments</u>	<u>Onsite Technology Status</u>
In-House Segregation	Separate toilet wastes from other wastewater	78-90% removal of N in blackwater	Management of residue required	Good
Biological Nitrification	Granular Filters	>90% conversion to nitrate	Achieves high level of BOD and solids removal	Good
	Aerobic package plants	85-95% conversion to nitrate	May achieve good levels of BOD and solids removal; labor/energy intensive; residue management	Good
Biological Denitrification	Anaerobic processes following nitrification	80-95% removal of N	Requires carbon source; labor intensive; high capital cost	Tentative
Ion Exchange	Cationic exchange-NH ₄ ⁺	>99% removal of NH ₄ ⁺ or NO ₃ ⁻	Very high operation costs	Tentative
	Anionic exchange-NO ₃			

^a Not including the soil absorption system--see Chapter 7.

of about 0.004 lb/cap/day (1.9 mg/cap/day) or 17 mg/l as N in the remaining graywater (Tables 4-4 and 4-5). Chapter 5 describes the process features, the performance, and the operation and maintenance of low-water carriage and waterless toilet systems. The resultant residuals from toilet segregation, whether they be ash, compost, chemical sludge, or blackwater,, must be considered in this treatment strategy. A discussion of residuals disposal is presented in Chapter 9.

The success of this method of nitrogen removal is dependent upon appropriate management of the in-house segregation fixtures and the disposal of the residues from them. These devices must be considered a part of the treatment system when developing appropriate authority for institutional control.

6.6.2.3 Biological Processes

Nitrogen undergoes a variety of biochemical transformations depending upon its form and the environmental conditions (61). Organic nitrogen in domestic wastewaters readily undergoes decomposition to ammonia in either aerobic or anaerobic conditions. In an aerobic environment, a select group of bacteria oxidize ammonia to nitrite and ultimately nitrate. Nitrates may be reduced by a variety of organisms to various nitrogen gas under anaerobic conditions. Depending upon the treatment objectives, one or several of these processes may be employed to achieve the desired end product.

a. Applicability

A number of biological processes for nitrogen conversion are applicable to onsite treatment. Domestic wastewater characteristics should not limit application of these processes, provided the nitrogen is in the appropriate form for conversion. Since biological processes are temperature-sensitive, such systems should be covered and insulated in cold climates. Covering also contains odors, should problems occur.

b. Process Performance

Although data are sketchy, about 2 to 10% of the total nitrogen from the home may be removed in the septic tank with septage (63)(64). Approximately 65 to 75% of the total nitrogen in septic tank effluents is in the ammonia-nitrogen form, indicating a significant level of decomposition of organic nitrogen (2).

Nitrification of septic tank effluents occurs readily within intermittent sand filters (see Section 6.3). Field experience indicates that intermittent sand filters loaded up to 5 gpd/ft² (0.02 cm³/m²/d), and properly maintained to avoid excessive ponding (and concomitant anaerobic conditions), converts up to 99% of the influent ammonia to nitrate-nitrogen (2). Aerobic biological package plants also provide a high degree of nitrification, provided solids retention times are long and sufficient oxygen is available (see Section 6.6).

The biological denitrification (nitrates to nitrogen gases) of wastewater follows a nitrification step (61). There has been little experience with long-term field performance of onsite denitrification processes. Ideally, total nitrogen removal in excess of 90% should be achievable, if the system is properly operated and maintained (61).

c. Design and Construction Features

Septic Tanks: There are no septic tank design requirements specifically established to enhance high levels of nitrogen removal. Designs that provide excellent solid-liquid separation ensure lower concentrations of nitrogen associated with suspended solids.

Nitrification: Biological nitrification is achieved by a select group of aerobic microorganisms referred to as nitrifiers (61). These organisms are relatively slow-growing and more sensitive to environmental conditions than the broad range of microorganisms found in biological wastewater treatment processes. The rate of growth of nitrifiers (and thus the rate of nitrification) is dependent upon a number of parameters, including temperature, dissolved oxygen, pH, and certain toxicants. The design and operating parameter used to reflect the growth rates of nitrifiers is the solids retention time (SRT). Details of the impact of temperature, dissolved oxygen, pH, and toxicants on design SRT values for nitrification systems are outlined in reference (61). In brief, biological nitrification systems are designed with SRT values in excess of 10 days; dissolved oxygen concentrations should be in excess of 2.0 mg/l; and pH values should range between 6.5 and 8.5. Toxicants known to be troublesome are discussed in reference (61).

Details of the design and construction of intermittent sand filters and aerobic package plants are found in Sections 6.3 and 6.4. In general, designs normally employed for onsite application of these processes to remove BOD and solids are sufficient to encourage nitrification as well.

Denitrification: Biological denitrification is carried out under anoxic conditions in the presence of facultative, heterotrophic microorganisms

which convert nitrate to nitrogen gases (61). Numerous microorganisms are capable of carrying out this process, provided there is an organic carbon source available. These organisms are less sensitive to environmental conditions than the nitrifiers, but the process is temperature-dependent. Process design and operational details for conventional denitrification processes are discussed in reference (61).

Design and operational experience with onsite biological denitrification systems is limited at this time (2)(65)(66). Several systems have been suggested for onsite application, two of which are shown in Figure 6-18. One employs a packed bed containing approximately 3/8-in. (1-cm) stone that receives, on a batch basis, effluent from a nitrification process. The nitrified wastewater flows to a dosing tank, where it is held until a predetermined volume is obtained. Methanol (or other organic carbon source) is then added to provide a C:N ratio of approximately 3:1. After approximately 15 min, the wastewater is pumped up through the anoxic packed stone bed. Effluent flows from the top of the bed. Liquid retention times in the packed bed (based on void volume) varying from 12 to 24 hours have been employed with good results (2). Pumping may be provided by a 1/3-hp submersible pump actuated by a switch float within the sump. A small chemical feed pump controlled by a timer switch may be used to feed the organic carbon source to the sump. A 30% methanol solution may be used as the carbon source. Other organic carbon sources include septic tank effluent, graywater, and molasses. Metering of organic carbon source to the nitrified wastewater requires substantial control to ensure a proper C:N ratio. Insufficient carbon results in decreased denitrification rates, whereas excess carbon contributes to the final effluent BOD (61). The use of an easily obtainable, slowly decomposable, solid carbon source could also be considered. Peat, forest litter, straw, and paper mill sludges, for example, could be incorporated as a portion of the upflow filter. Control of the denitrification process using these solid carbon sources would be difficult.

Another onsite nitrification-denitrification system that has been field tested employs a soil leach field (66) (Figure 6-18). Septic tank effluent is distributed to a standard soil absorption field. An impermeable shield of fiberglass is placed approximately 5 ft (1.5 m) below the distribution line. The location of this collector should be deep enough to ensure complete nitrification within the overlying unsaturated soil. The nitrified wastewater is collected on the sloped fiberglass shield, and directed to a 24-in. (61-cm) deep bed of pea gravel contained within a plastic liner (denitrifying reactor). The gravel bed is sized deep enough to provide a hydraulic detention time of approximately 10 days (based on void volume). Methanol or other energy source is metered to the gravel bed through a series of distributors. The gravel bed is vented with vertical pipes to allow escape of nitrogen gas evolved in the process. Short-term experience with this system has been good. Total nitrogen concentrations of less than 1 mg/l-N were achievable in

FIGURE 6-18

ONSITE DENITRIFICATION SYSTEMS

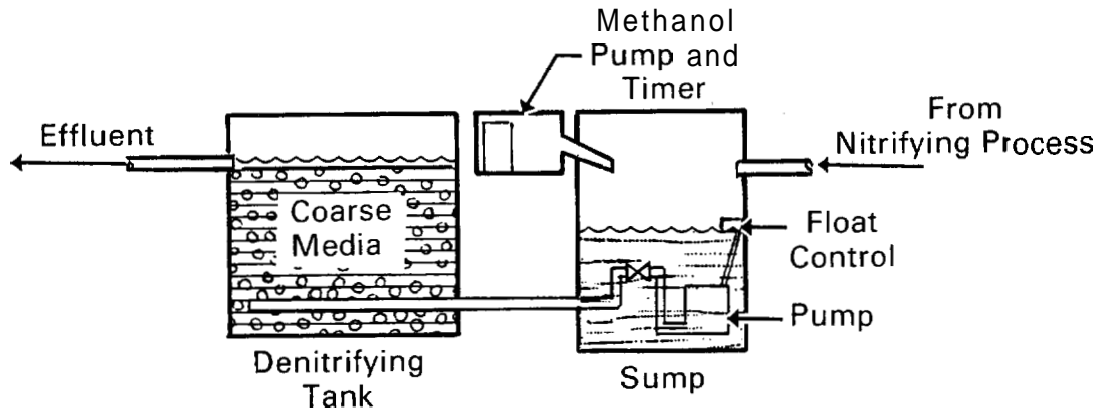

Batch Denitrification

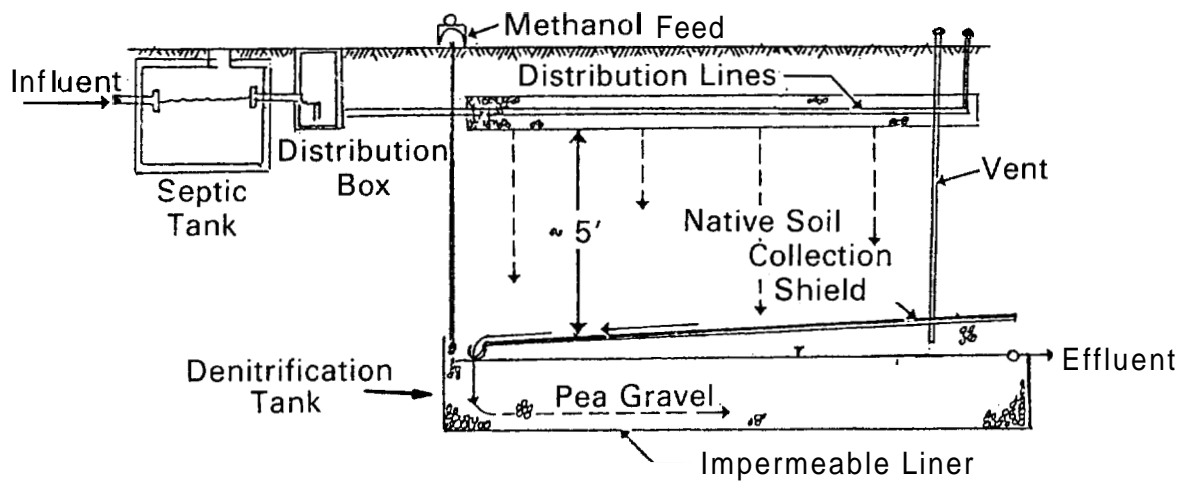

Nitrification-Denitrification in Soil

effluent samples during summer months. Higher values (5-10 mg/l-N) were observed during the colder winter months.

Although no studies have been reported in the literature for onsite applications, intermittent or cycled extended aeration processes are potentially promising (61)(67) for the nitrification-denitrification of wastewater. This process makes use of existing proprietary extended aeration package plants where aeration is cycled to provide both aerobic and anoxic environments. In this mode of operation, sufficient solids retention time (SRT) is provided to insure nitrification, and a sufficient period of anoxic holding is provided to insure denitrification. The biomass serves as the energy source for denitrification. The cycle times vary dependent on temperature and wastewater characteristics. A typical cycle, using a SRT of 20 days, aerates 180 min and holds anoxic for 90 min (67). Nitrogen removals in excess of 50% are attainable with this system (2)(67). Operation of the cyclic aeration system requires substantial supervision for a period of time until proper sequences have been selected.

d. Operation and Maintenance

Nitrification Systems: Operation and maintenance requirements to achieve nitrification in either intermittent sand filters or aerobic package units are not significantly different from those discussed in Sections 6.3 and 6.4. In both systems, the process must be maintained in an aerobic condition at all times to ensure effective nitrification.

Denitrification Systems: Operation and maintenance requirements for denitrification systems are normally complex and require semi-skilled labor for proper performance. In addition to routine maintenance of pumping systems, mixers, and timer controls, the addition and balance of a carbon source is required.

Routine analyses of nitrogen compounds and biological solids is also important. Rough estimates for semi-skilled labor for maintenance of an onsite denitrification system varies from 15 to 30 man-hr per yr. If methanol is used as a carbon source, it is estimated that from 33 to 55 lb/yr (15 to 25 kg/yr) are required for a family of four. Power requirements for methanol feed and pumping are about 15 to 25 kWh/yr.

6.6.2.4 Ion Exchange

Ion exchange is a process whereby ions of a given species are displaced from an insoluble exchange material by ions of a different species in

solution. It can be used to remove either ammonium or nitrate nitrogen from wastewaters. This process has been employed in full-scale water and wastewater treatment plants for several years (61)(67)(68), but there is no long-term experience with the process for nitrogen removal in onsite applications.

Nitrogen removal by ion exchange has potential for onsite application, since it is very effective and is simple to operate. Unfortunately, periodic replacement of the exchange media is expensive and regeneration of the media onsite does not appear to be practical at this time. Site conditions and climatological factors should not limit its application.

a. Ammonia Removal

Ammonia removal may be achieved by employing the naturally occurring exchange media, clinoptilolite, which has a high affinity for the ammonium ion (61). Laboratory experience has shown that packed columns of clinoptilolite resin (20 x 40 mesh) will effectively remove ammonium ion from septic tank effluent without serious clogging problems (2). Regeneration with 5% NaCl was successful over numerous trials. Breakthrough exchange capacity of this resin was found to be about 0.4 meq NH_4^+ /gram in hard water at application rates of 10 bed volumes per hr. (This value will vary, increasing with decreased hardness.) Very large quantities of resin are required to treat household wastewaters (approximately 10 lb per day). Treatment of segregated graywaters substantially lower in ammonium concentration decreases the amount of resin needed.

This process employs a packed column or bed of the exchange resin following a septic tank. The waste is pumped from a sump to the column in an upflow or downflow mode on a periodic basis. Once the resin has been exhausted, it is removed and replaced by fresh material. Regeneration occurs offsite.

Operation and maintenance of this process requires routine maintenance of the pump and occasional monitoring of ammonium levels from the process. Replacement of exhausted resin is dictated by wastewater characteristics and bed volume. There are insufficient data at this time to delineate labor, power, and resin requirements.

b. Nitrate Removal

Nitrate removal from water may be achieved by the use of strong and weak base ion exchange resins (68)(69). There are very little data available

on long-term performance of these nitrate removal systems for wastewater. Numerous anions in water compete with nitrate for sites on these resins; therefore, tests on the specific wastewater to be treated need to be performed.

This process has potential for onsite application, where it would follow a nitrification process such as intermittent sand filters. As with ammonia resins, regeneration is performed off site.

There is insufficient information on nitrate exchange to provide design, construction, operation, and maintenance data at this time.

6.6.3 Phosphorus Removal

6.6.3.1 Description

Table 6-27 outlines the most likely treatment processes available for onsite removal of phosphorus in wastewater. In many instances, these processes will also achieve other treatment objectives as well, and must be evaluated as to their overall performance.

6.6.3.2 In-House Processes

Review of Chapter 4 indicates that the major sources of phosphorus in the home are laundry, dishwashing, and toilet wastewaters. Contributions of phosphorus in the home could be reduced from approximately 4 to 2 gm/cap/day through the use of 0.5% phosphate detergents.

Segregation of toilet wastewaters (blackwater) from household wastewaters reduces phosphorus levels to approximately 2.8 gm/cap/day in the graywater stream. Chapter 4 describes the process features, performance, and operation and maintenance of low-water carriage and waterless toilet systems that would be employed for this segregation. Note that the resultant residues from these toilet systems must be considered in this treatment strategy. A discussion of residuals disposal appears in Chapter 9.

As with any in-house measure to reduce pollutional loads, the success of the process is dependent upon owner commitment and appropriate management of the alternative plumbing equipment.

TABLE 6-27

POTENTIAL ONSITE PHOSPHORUS REMOVAL OPTIONS

<u>Option</u>	<u>Description</u>	<u>Effectiveness</u>	<u>Comments</u>	<u>Onsite Technology Status</u>
In-House Segregation	Laundry detergent substitution	50% P removal	0.5% P detergents available	Excellent
	Separate toilet wastes from other wastewaters	20-40% P removal	Management of residues required; achieves significant BOD, SS reduction	Good
194	Chemical Precipitation: Iron, Calcium and Aluminum salts	up to 90% P removal	Increases quantity of sludge; labor intensive	Fair
	Sorption Processes: Calcite or Iron	up to 90% P removal	Replacement required	Tentative
	Alumina	90-99% P removal	High cost for material, labor intensive	Tentative

6.6.3.3 Chemical Precipitation

Phosphorus in wastewater may be rendered insoluble by a selected number of metal salts, including aluminum, calcium, and iron (62). Although the reactions are complex, the net result is the precipitation of an insoluble complex that contains phosphate. Phosphorus precipitation methods normally include the addition of the chemical, high-speed mixing, and slow agitation followed by sedimentation.

There has been little long-term experience with phosphorus removal of wastewaters onsite (2)(70). Precipitation of phosphates is less easily accomplished for polyphosphates and organic phosphorus than for orthophosphate. Therefore, precipitation within the septic tanks, although simpler to manage, may not remove a significant portion of the phosphate, which is in the poly and organic form. Substantial hydrolysis of these forms may occur in the septic tank, however, producing the orthoform. Thus, precipitation following the septic tank may achieve higher overall removals of total phosphorus.

Performance is dependent on the point of chemical addition, chemical dosage, wastewater characteristics, and coagulation and sedimentation facilities. Dose-performance relationships must be obtained through experimentation, but one should expect phosphorus removals between 75 and 90%. Improvement in this performance may be achieved if intermittent sand filters follow the precipitation/sedimentation process. Side benefits are achieved with the addition of the precipitating chemicals. Suspended and colloidal BOD and solids will be carried down with the precipitate, producing a higher quality effluent than would otherwise be expected.

Chemical precipitation of wastewaters generates more sludge than do conventional systems due to both the insoluble end product of the added chemical and the excess suspended and colloidal matter carried down with it. Estimates of this increased quantity are very crude at this time, but may range from 200 to 300% by weight in excess of the sludge normally produced from a septic tank system.

a. Process Features

The chemicals most often used for phosphate precipitation are aluminum and iron compounds. Calcium salts may also be used, but require pH adjustment prior to final discharge to the environment. Aluminum is generally added as alum ($\text{Al}_2\text{SO}_4 \cdot n \text{H}_2\text{O}$). Ferric chloride and ferric sulfate are the most commonly used iron salts.

Anionic polyelectrolytes can be used in combination with the aluminum and iron salts to improve settling, but may overly complicate the onsite treatment system.

The required dosages of aluminum and iron compounds are generally reported as molar ratios of trivalent metal salt to phosphate phosphorus. Molar ratios currently used in practice today range from 1.5:1 to 4:1, depending upon wastewater characteristics, point of addition, and desired phosphorus removal (20)(62).

Adding aluminum or iron salts to the raw wastewater prior to the septic tank has the advantage of using the existing septic tank for sedimentation (70). Aluminum or iron salts may be metered to the raw wastewater with a chemical feed pump activated by electrical or mechanical impulse. Mixing of the chemical with the wastewater is provided in the sewer line to the septic tank. The quantity of metal salt added to the wastewater is dependent upon wastewater characteristics. Since the impulse to the feed pump may come from any of a number of household events, it is not possible to precisely adjust metal dosage. An average dose of salt based on estimated phosphorus discharge is most practical.

Addition of iron or aluminum salts following the septic tank may also be considered. A batch feed system could be employed whereby a preset chemical dose is provided when the wastewater reaches a preset volume in a holding tank. Mixing may be provided by aeration or mechanical mixer, followed by a period of quiescence. Additional raw wastewater flow would be diverted to a holding tank until the precipitation-sedimentation cycle is completed. This system may be employed after the septic tank and preceding the intermittent sand filter.

The processes briefly described above represent a few of the many chemical treatment processes that might be considered for onsite treatment. They may be designed and constructed to fit the specific needs of the site, or purchased as a proprietary device. Storage and holding of chemicals must be considered in the design of these systems. Details on chemical storage, feeding, piping, and control systems may be found elsewhere (20)(62). Attention must be given to appropriate materials selection, since many of the metal salts employed are corrosive in liquid form.

b. Operation and Maintenance

Every effort should be made to select equipment that is easily operated and maintained. Nonetheless, chemical precipitation systems require semi-skilled labor to maintain chemical feed equipment, mixers, pumps,

and electronic or mechanical controls. More frequent pumping of wastewater sludge or septage is also required. A rough estimate for semi-skilled labor is 10 to 25 man-hr per yr depending upon the complexity of the equipment. Conservative estimates on sludge accumulation dictate sludge or septage pumping every 0.5 to 2 years for an average home. Chemical requirements would vary widely, but are estimated to range from 22 to 66 lb/yr Al (10 to 30 kg/yr) or 11 to 33 lb/yr Fe (5 to 15 kg/yr) for a family of four.

6.6.3.4 Surface Chemical Processes

Surface chemical processes, which include ion exchange, sorption, and crystal growth reactions, have received little application in treatment of municipal wastewaters, but hold promise for onsite application (62). These types of processes are easy to control and operate; the effluent quality is not influenced by fluctuations in influent concentration; and periods of disuse between applications should not affect subsequent performance. Phosphorus removal on selected anion exchange resins has been demonstrated, but control of the process due to sulfate competition for resin sites has discouraged its application (71). Phosphorus removal by sorption in columns or beds of calcite or other high-calcium, iron, or aluminum minerals is feasible; but long-term experience with these materials has been lacking (2)(25)(72). Many of these naturally occurring materials have limited capacity to remove phosphorus, and some investigations have demonstrated the development of biological slimes that reduce the capacity of the mineral to adsorb phosphorus. Table 6-28 lists a range of phosphorus adsorption capacities of several materials that may be considered. The use of locally available calcium, iron, or aluminum as naturally occurring materials, or as wastewater products from industrial processing, may prove to be cost-effective; but transport of these materials any distance normally rules out their widespread application. Incorporation of phosphate-sorbing materials within intermittent sand filters is discussed more fully in Section 6.3.5.

The use of alumina (Al_2O_3), a plentiful and naturally occurring material for sorption of phosphorus, has been demonstrated in laboratory studies, but has not yet been employed in long-term field tests (75). Alumina has a high affinity for phosphorus, and may be regenerated with sodium hydroxide. Application of an alumina sorption process is similar to ion exchange, whereby a column or bed would be serviced by replacement on a routine basis. Costs for this process are high.

6.7 Wastewater Segregation and Recycle Systems

Chapter 5 discusses in detail in-house methods that may be employed to modify the quality of the wastewater. These processes are an important

component of the onsite treatment system as they remove significant quantities of pollutants from the wastewater prior to further treatment and/or disposal.

TABLE 6-28
PHOSPHORUS ADSORPTION ESTIMATES FOR SELECTED
NATURAL MATERIALS (73)(74)(75)^a

<u>Media</u>	<u>Adsorption</u> (mg P/100 gm media)
Acid Soil Outwash	10 - 35
Calcereous Soil Outwash	5 - 30
Sandy Soils	2 - 20
F-1 Alumina (Al ₂ O ₃), 24-48 mesh	700 - 1500

^a Based on maximum Langmuir isotherm values.

6.7.1 Wastewater Segregation

Among the wastewater segregation components which significantly alter wastewater quality are the non-water carriage toilets (Table 5-31, and the very low water flush toilets (Table 5-2) with blackwater containment. Impacts of wastewater modification on onsite disposal practices are outlined in Table 5-9.

The graywater resulting from toilet segregation practices normally require some treatment prior to disposal (Tables 4-4 and 4-5 - "Basins, Sinks, and Appliances"). Treatment methods for graywater are similar to those employed for household wastewaters (Sections 6.2 to 6.6 and Figure 5-2), but performance data are lacking.

Residuals resulting from the treatment or holding of segregated waste streams must be considered when evaluating these alternatives. Details of the characterization and disposal of these residuals appear in Chapter 9.

6.7.2 Wastewater Recycle

In-house wastewater recycle systems are treatment systems employed to remove specific pollutants from one or more wastewater streams in order to meet a specific water use objective (for example, graywater may be treated to a quality that is acceptable for flushing toilets, watering lawns, etc.). These systems are summarized in Table 5-6.

The impact of recycle systems on the quality of wastewater to be ultimately disposed is difficult to assess at this time owing to the absence of long term experience with these systems. It is likely that substantial pollutant mass reduction will occur in addition to flow reduction. As with segregated systems, the disposal of residuals from these processes must be considered in system evaluation.

6.8 References

1. Jones, E. E. Septic Tank - Configuration versus Performance. Presented at the 2nd Pacific Northwest On-Site Wastewater Disposal Short Course, University of Washington, Seattle, March 1978.
2. Small Scale Waste Management Project, University of Wisconsin, Madison. Management of Small Waste Flows. EPA 600/2-78-173, NTIS Report No. PB 286 560, September 1978. 804 pp.
3. Weibel, S. R., C. P. Straub, and J. R. Thoman. Studies on Household Sewage Disposal Systems, Part I - NTIS Report No. PB 217 671, Environmental Health Center, Cincinnati, Ohio, 1949. 279 pp.
4. Salvato, J. A. Experience with Subsurface Sand Filters. Sewage and Industrial Wastes, 27(8):909, 1955.
5. Bernhart, A. P. Wastewater from Homes. University of Toronto, Toronto, Canada, 1967.
6. Laak, R. Wastewater Disposal Systems in Unsewered Areas. Final Report to Connecticut Research Commission, Civil Engineering Department, University of Connecticut, Storrs, 1973.

7. Brandes, M. Characteristics of Effluents from Separate Septic Tanks Treating Gray and Black Waters from the Same House. *J. Water Pollut. Control Fed.*, 50:2547-2559, 1978.
8. Weibel, S. R., T. W. Bendixen, and J. B. Coulter. Studies on Household Sewage Disposal Systems, Part III. NTIS Report No. PB 217 415, Environmental Health Center, Cincinnati, Ohio, 1954. 150 pp.
9. Plews, G. D. The Adequacy and Uniformity of Regulations for On-Site Wastewater Disposal - A State Viewpoint. In: National Conference on Less Costly Wastewater Treatment Systems for Small Communities. EPA 600/9-79-010, NTIS Report No. PB 293 254, April 1977. pp. 20-28.
10. Manual of Septic Tank Practices. NTIS Report No. PB 216 240, Public Health Service, Washington, D.C., 1967. 92 pp.
11. Baumann, E. R., E. E. Jones, W. M. Jakubowski, and M. C. Nottingham. Septic Tanks. In: Proceedings of the Second National Home Sewage Treatment Symposium, Chicago, Illinois, December 1977. American Society of Agricultural Engineers, St. Joseph, Michigan, 1978. pp. 38-53.
12. Weibel, S. R. Septic Tanks: Studies and Performance. *Agric. Eng.*, 36:188-191, 1955.
13. Harris, S. E., J. H. Reynolds, D. W. Hill, D. S. Filip, and E. J. Middlebrooks. Intermittent Sand Filtration for Upgrading Waste Stabilization Pond Effluents. *J. Water Pollut. Control Fed.* 49:83-102, 1977.
14. Schwartz, W. A., T. W. Bendixen, and R. E. Thomas. Project Report of Pilot Studies on the Use of Soils as Waste Treatment Media; In-house Report. Federal Water Pollution Control Agency, Cincinnati, Ohio, 1967.
15. Metcalf, L., and H. P. Eddy. *American Sewerage Practice*. 3rd ed., Volume III. McGraw-Hill, New York, 1935. 892 pp.
16. Boyce, E. Intermittent Sand Filters for Sewage. *Munic. Cty. Eng.*, 72:177-179, 1927.
17. Recommended Standards for Sewage Works. Great Lakes-Upper Mississippi River Board of State Sanitary Engineers, Albany, New York, 1960. 138 pp.
18. Filtering Materials for Sewage Treatment Plants. Manual of Engineering Practice No. 13, American Society of Civil Engineers, New York, 1937. 40 pp.

19. Salvato, J. A., Jr. Experience With Subsurface Sand Filters. *Sew. Ind. Wastes*, 27:909-916, 1955,
20. Wastewater Treatment Plant Design. Manual of Practice No. 8, Water Pollution Control Federation, Washington, D.C., 1977. 560 p.
21. Clark, H. W. and S. Gage. A Review of Twenty-one Years of Experiments upon the Purification of Sewage at the Lawrence Experimental Station. 40th Annual Report, State Board of Health of Massachusetts, Wright E. Potter, Boston, Massachusetts, 1909. 291 pp.
22. Brandes, M. Effect of Precipitation and Evapotranspiration on Filtering Efficiency of Wastewater Disposal Systems. Publication No. W70, Ontario Ministry of Environment, Toronto, Canada, May 1970.
23. Emerson, D. L., Jr. Studies on Intermittent Sand Filtration of Sewage. Florida Engineering and Industrial Experimental Station Bulletin No. 9, University of Florida College of Engineering, Gainesville, 1954.
24. Hines, J., and R. E. Favreau. Recirculating Sand Filter: An Alternative to Traditional Sewage Absorption Systems. In: Proceedings of the National Home Sewage Disposal Symposium, Chicago, Illinois, December 1974. American Society of Agricultural Engineers, St. Joseph, Michigan, 1975. pp. 130-136.
25. Brandes, M., N. A. Chowdhry, and W. W. Cheng. Experimental Study on Removal of Pollutants From Domestic Sewage by Underdrained Soil Filters. In: Proceedings of the National Home Sewage Disposal Symposium, Chicago, Illinois, December 1974. American Society of Agricultural Engineers, St. Joseph, Michigan, 1975. pp. 29-36.
26. Teske, M. G. Recirculation - An Old Established Concept Solves Same Old Established Problems. Presented at the 51st Annual Conference of the Water Pollution Control Federation, Anaheim, California, 1978.
27. Bowne, W. C. Experience in Oregon With the Hines-Favreau Recirculating Sand Filter. Presented at the Northwest States Conference on Onsite Sewage Disposal, 1977.
28. Chowdhry, N. A. Underdrained Filter Systems - Whitby Experiment Station. Ministry of the Environment Interim Report Part 2. Toronto, Canada, 1973.
29. Kennedy, J. C. Performance of Anaerobic Filters and Septic Tanks Applied to the Treatment of Residential Wastewater. M.S. Thesis, University of Washington, Seattle, 1979.

30. Bernhart, A. P. Wastewater From Homes. University of Toronto, Toronto, Canada, 1967.
31. Voell, A. T. and R. A. Vance. Home Aerobic Wastewater Treatment Systems - Experience in a Rural County. Presented at the Ohio Home Sewage Disposal Conference, Ohio State University, Columbus, 1974.
32. Tipton, D. W. Experiences of a County Health Department with Individual Aerobic Sewage Treatment Systems. Jefferson County Health Department, Lakewood, Colorado, 1975.
33. Brewer, W. S., J. Lucas, And G. Prascak. An Evaluation of the Performance of Household Aerobic Sewage Treatment Units. Journal of Environmental Health, 41:82-85, 1978.
34. Glasser, M. B. Garrett County Home Aeration Wastewater Treatment Project. Bureau of Sanitary Engineering, Maryland State Department of Health and Mental Hygiene, Baltimore, 1974.
35. Hutzler, N. J., L. E. Waldorf, and J. Fancy. Performance of Aerobic Treatment Units. In: Proceedings of the Second National Home Sewage Treatment Symposium, Chicago, Illinois, December 1977. American Society of Agricultural Engineers, St. Joseph, Michigan, 1978. pp. 149-163.
36. Operation of Wastewater Treatment Plants. Manual of Practice No. 11, Water Pollution Control Federation, Washington, D.C., 1976. 547 pp.
37. Tsugita, R. A., D. C. W. Decoite, and L. Russell. Process Control Manual for Aerobic Biological Wastewater Treatment Facilities. EPA 430/9-77-006, NTIS Report No. PB 279 474, James M. Montgomery Inc., 1977. 335 pp.
38. Process Design Manual, Wastewater Treatment Facilities for Sewered Small Communities. EPA-625/1-77-009, U.S. Environmental Protection Agency, Cincinnati, Ohio, 1977.
39. Craun, C. F. Waterborne Disease - A Status Report Emphasizing Outbreaks in Ground Water Systems. Ground Water, 17:183-191, 1979.
40. Craun, C. F. Disease Outbreaks Caused by Drinking Water. J. Water Pollut. Control Fed., 50:1362-1375, 1978.
41. Jakubowski, W., and J. C. Hoff, eds. Waterborne Transmission of Giardiasis. EPA 600/9-79-001, NTIS Report No. PB 299 265, U. S. Environmental Protection Agency, Health Effects Research Laboratory, Cincinnati, Ohio, June 1979. 306 pp.
42. Berg, G, ed. Transmission of Viruses by the Water Route. Wiley, New York, 1967. 502 pp.

43. Chang, S. L. Modern Concept of Disinfection. J. Sanit. Eng. Div., Am. Soc. Civil Eng., 97:689-707, 1971.
44. White, G. C. Handbook of Chlorination. Van Nostrand Reinhold, New York, 1972. 751 pp.
45. Morris, J. C. Chlorination and Disinfection: State of the Art. J. Am. Water Works Assoc., 63:769-774, 1971.
46. McKee, J. E. Report on the Disinfection of Seattle Sewerage. California Institute of Technology, Pasadena, California, April 1957.
47. Budde, P. E., P. Nehm, and W. C. Boyle. Alternatives to Wastewater Disinfection, J. Water Pollut. Control Fed., 49:2144-2156, 1977.
48. Black, A. P. Better Tools for Treatment. J. Am. Water Works Assoc., 58:137-146 1966.
49. Baker, R. J. Characteristics of Chlorine Compounds. J. Water Pollut. Control Fed., 41:482-485, 1969.
50. Jepson, J. D. Disinfection of Water Supplies by Ultraviolet Irradiation. Water Treat. Exam., 22:175-193, 1973.
51. Huff, C. B., H. F. Smith, W. D. Boring, and N. A. Clarke. Study of Ultraviolet Disinfection of Water and Factors in Treatment Efficiency. Pub. Health Rep., 80:695-705, 1965.
52. Scheible, O. K., G. Binkowski, and T. J. Mulligan. Full Scale Evaluation of Ultraviolet Disinfection of a Secondary Effluent. In: Progress in Wastewater Disinfection Technology, EPA 600/9-79-018, NTIS Report No. PB 299 338, Municipal Environmental Research Laboratory, Cincinnati, Ohio, 1979. pp. 117-125.
53. Kreissl, J. F., and J. M. Cohen. Treatment Capability of a Physical Chemical Package Plant. Water Res., 7:895-909, 1973.
54. Rosen, H. M. Ozone Generation and Its Economical Application in Wastewater Treatment. Water Sew. Works, 119:114-120, 1972.
55. Johansen, R. P., and D. W. Terry. Comparison of Air and Oxygen Recycle Ozonation Systems. Presented at the Symposium on Advanced Ozone Technology, Toronto, Canada, November 1977.
56. Majumdar, S. B., and O. J. Sproul. Technical and Economic Aspects of Water and Wastewater Ozonation: A Critical Review. Water Res., 8:253-260, 1974.
57. McCarthy, J. J., and C. H. Smith. A Review of Ozone and Its Application to Domestic Wastewater Treatment. J. Am. Water Works Assoc., 66:718-725, 1974.

58. Poynter, S. F., J. S. Slade, and H. H. Jones. The Disinfection of Water with Special Reference to Viruses. *Water Treat. Exam.*, 22:194-208, 1973.
59. Scaccia, C., and H. M. Rosen. Ozone Contacting: What is the Answer? Presented at the Symposium on Advanced Ozone Technology, International Ozone Institute, Toronto, Canada, November 1977.
60. Venosa, A. D., M. C. Meckes, E. J. Opatken, and J. W. Evans. Comparative Efficiencies of Ozone Utilization and Microorganism Reduction in Different Ozone Contactors. In: *Progress in Wastewater Disinfection Technology*, EPA 600/9-79-018, NTIS Report No. PB 299 338, MERL, Cincinnati, Ohio, 1979, pp. 141-161.
61. Process Design Manual for Nitrogen Control. EPA 625/1-75-007, United States Environmental Protection Agency, Center for Environmental Research Information, Cincinnati, Ohio, October 1975. 434 pp.
62. Process Design Manual for Phosphorus Removal. EPA 625/1-76-001, United States Environmental Protection Agency, Center for Environmental Research Information, Cincinnati, Ohio, April 1976.
63. Brandes, M. Accumulation Rate and Characteristics of Septic Tank Sludge and Septage. *J. Water Pollut. Control Fed.*, 50: 936-943, 1978.
64. Laak, R., and F. J. Crates. Sewage Treatment by Septic Tank. In: *Proceedings of the Second Home Sewage Treatment Symposium*, Chicago, Illinois, December 1977. American Society of Agricultural Engineers, St. Joseph, Michigan, 1978. pp. 54-60.
65. Sikora, L. J., and D. R. Keeney. Laboratory Studies on Stimulation of Biological Denitrification. In: *Proceedings of the National Home Sewage Disposal Symposium*, Chicago, Illinois, December 1975, American Society of Agricultural Engineers, St. Joseph, Michigan, 1975. pp. 64-73.
66. Andreoli, A., N. Bartilucci, R. Forgione, and R. Reynolds. Nitrogen Demand in a Subsurface Disposal System. *J. Water Pollut. Control Fed.*, 51:841-854, 1979.
67. Goronszy, M. C. Intermittent Operation of the Extended Aeration Process for Small Systems. *J. Water Pollut. Control Fed.*, 51:274, 1979.
68. Clifford, D. A., and W.J. Weber, Jr. Multicomponent Ion Exchange: Nitrate Removal Process with Land Disposal Regenerant. *Ind. Water Eng.*, 15:18-26, 1978.

69. Beulow, R. W., K. L. Kropp, J. Withered, and J. M. Symons. Nitrate Removal by Anion Exchange Resins. Water Supply Research Laboratory, National Environmental Research Center, Cincinnati, Ohio, 1974.
70. Brandes, M. Effective Phosphorus Removal by Adding Alum to Septic Tank. J. Water Pollut. Control Fed., 49:2285-2296, 1977.
71. Midkiff, W. S., and W. J. Weber, Jr. Operating Characteristics of Strong Based Anion Exchange Reactor. Proc. Ind. Waste Conf., 25:593-604, 1970.
72. Erickson, A. E., J. M. Tiedje, B. G. Ellis, and C. M. Hansen. A Barrired Landscape Water Renovation System for Removing Phosphate and Nitrogen from Liquid Feedlot Waste. In: Livestock Waste Management Pollution Abatement; Proceedings of the International Symposium on Livestock Wastes, St. Joseph, Michigan, 1971. pp. 232-234.
73. Ellis, B. G., and A. E. Erickson. Movement and Transformation of Various Phosphorus Compounds in Soils. Michigan Water Resources Commission, Lansing, 1969.
74. Tofflemire, T. J., M. Chen, F. E. Van Alstyne, L. J. Hetling, and D. B. Aulenbach. Phosphate Removal by Sands and Soils. Research Unit Technical Paper 31, New York State Department of Environmental Conservation, Albany, 1973. 92 pp.
75. Detweiler, J. C. Phosphorus Removal by Adsorption on Alumina as Applied to Small Scale Waste Treatment. MS. Report. University of Wisconsin, Madison, 1978.

CHAPTER 7

DISPOSAL METHODS

7.1 Introduction

Under the proper conditions, wastewater may be safely disposed of onto the land, into surface waters, or evaporated into the atmosphere by a variety of methods. The most commonly used methods for disposal of wastewater from single dwellings and small clusters of dwellings may be divided into three groups: (1) subsurface soil absorption systems, (2) evaporation systems, and (3) treatment systems that discharge to surface waters. Within each of these groups, there are various designs that may be selected based upon the site factors encountered and the characteristics of the wastewater. In some cases, a site limitation may be overcome by employing flow reduction or wastewater segregation devices (see Chapter 6). Because of the broad range of possible alternatives, the selection of the most appropriate design can be difficult. The site factor versus system design matrix presented in Chapter 2 should be consulted to aid in this selection.

Onsite disposal methods discussed in this chapter are:

1. Subsurface soil absorption systems
 - trenches and beds
 - seepage pits
 - mounds
 - fills
 - artificially drained systems
 - electro-osmosis
2. Evaporation systems
 - evapotranspiration and evapotranspiration-absorption
 - evaporation and evaporation-percolation ponds
3. Treatment systems that discharge to surface waters

Performance data and design, construction, operation, and maintenance information are provided for each of these methods.

7.2 Subsurface Soil Absorption

7.2.1 Introduction

Where site conditions are suitable, subsurface soil absorption is usually the best method of wastewater disposal for single dwellings because of its simplicity, stability, and low cost. Under the proper conditions, the soil is an excellent treatment medium and requires little wastewater pretreatment. Partially treated wastewater is discharged below ground surface where it is absorbed and treated by the soil as it percolates to the groundwater. Continuous application of wastewater causes a clogging mat to form at the infiltrative surface, which slows the movement of water into the soil. This can be beneficial because it helps to maintain unsaturated soil conditions below the clogging mat. Travel through two to four feet of unsaturated soil is necessary to provide adequate removals of pathogenic organisms and other pollutants from the wastewater before it reaches the groundwater. However, it can reduce the infiltration rate of soil substantially. Fortunately, the clogging mat seldom seals the soil completely. Therefore, if a subsurface soil absorption system is to have a long life, the design must be based on the infiltration rate through the clogging mat that ultimately forms. Formation of the clogging mat depends primarily on loading patterns, although other factors may impact its development.

7.2.1.1 Types of Subsurface Soil Absorption Systems

Several different designs of subsurface soil absorption systems may be used. They include trenches and beds, seepage pits, mounds, fills, and artificially drained systems. All are covered excavations filled with porous media with a means for introducing and distributing the wastewater throughout the system. The distribution system discharges the wastewater into the voids of the porous media. The voids maintain exposure of the soil's infiltrative surface and provide storage for the wastewater until it can seep away into the surrounding soil.

These systems are usually used to treat and dispose of septic tank effluent. While septic tank effluent rapidly forms a clogging mat in most soils, the clogging mat seems to reach an equilibrium condition through which the wastewater can flow at a reasonably constant rate, though it varies from soil to soil (1)(2)(3)(4). Improved pretreatment of the wastewater does not appear to reduce the intensity of clogging, except in coarse granular soils such as sands (4)(5)(6).

7.2.1.2 System Selection

The type of subsurface soil absorption system selected depends on the site characteristics encountered. Critical site factors include soil profile characteristics and permeability, soil depth over water tables or bedrock, slope, and the size of the acceptable area. Where the soil is at least moderately permeable and remains unsaturated several feet below the system throughout the year, trenches or beds may be used. Trenches and beds are excavations of relatively large areal extent that usually rely on the upper soil horizons to absorb the wastewater through the bottom and sidewalls of the excavation. Seepage pits are deep excavations designed primarily for lateral absorption of the wastewater through the sidewalls of the excavation; they are used only where the groundwater level is well below the bottom of the pit, and where beds and trenches are not feasible.

Where the soils are relatively impermeable or remain saturated near the surface, other designs can be used to overcome some limitations. Mounds may be suitable where shallow bedrock, high water table, or slowly permeable soil conditions exist. Mounds are beds constructed above the natural soil surface in a suitable fill material. Fill systems are trench or bed systems constructed in fill material brought in to replace unsuitable soils. Fills can be used to overcome some of the same limitations as mounds. Curtain or underdrain designs sometimes can be used to artificially lower groundwater tables beneath the absorption area so trenches or beds may be constructed. Table 2-1 presents the general site conditions under which the various designs discussed in this manual are best suited. For specific site criteria appropriate for each, refer to the individual design sections in this chapter.

7.2.2 Trench and Bed Systems

7.2.2.1 Description

Trench and bed systems are the most commonly used method for onsite wastewater treatment and disposal. Trenches are shallow, level excavations, usually 1 to 5 ft (0.3 to 1.5 m) deep and 1 to 3 ft (0.3 to 0.9 m) wide. The bottom is filled with 6 in. (15 cm) or more of washed crushed rock or gravel over which is laid a single line of perforated distribution piping. Additional rock is placed over the pipe and the rock covered with a suitable semipermeable barrier to prevent the backfill from penetrating the rock. Both the bottoms and sidewalls of the trenches are infiltrative surfaces. Beds differ from trenches in that they are wider than 3 ft (0.9 m) and may contain more than one line of distribution piping (see Figures 7-1 and 7-2). Thus, the bottoms of the beds are the principal infiltrative surfaces.

FIGURE 7-1
TYPICAL TRENCH SYSTEM

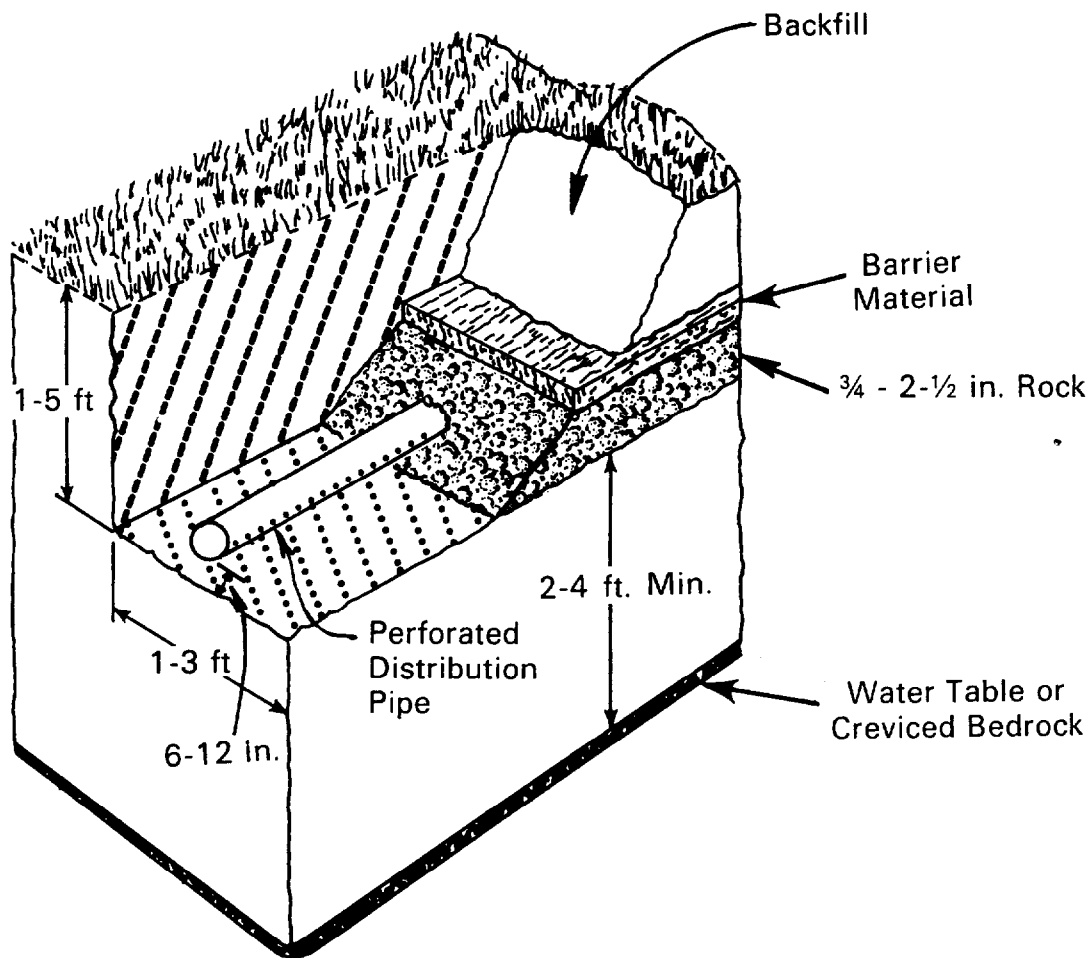
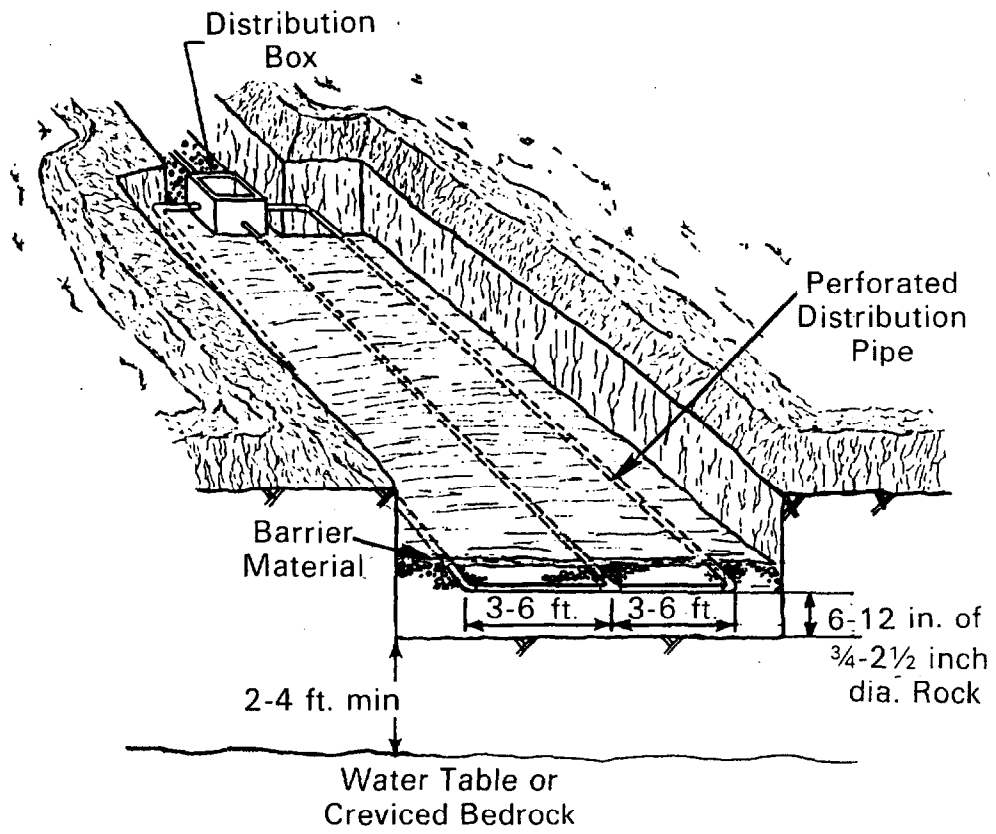

FIGURE 7-2
TYPICAL BED SYSTEM



7.2.2.2 Application

Site criteria for trench and bed systems are summarized in Table 7-1. They are based upon factors necessary to maintain reasonable infiltration rates and adequate treatment performance over many years of continuous service. Chapter 3 should be consulted for proper site evaluation procedures.

The wastewater entering the trench or bed should be nearly free from settleable solids, greases, and fats. Large quantities of these wastewater constituents hasten the clogging of the soil (9). The organic strength of the wastewater has not been well correlated with the clogging mat resistance except in granular soils (4)(5). Water softener wastes have not been found to be harmful to the system even when significant amounts of clay are present (9)(10). However, the use of water softeners can add a significant hydraulic load to the absorption system and should be taken into account. The normal use of other household chemicals and detergents have also been shown to have no ill effects on the system (9).

7.2.2.3 Design

a. Sizing the Infiltrative Surface

The design of soil absorption systems begins at the infiltrative surface where the wastewater enters the soil. With continued application of wastewater, this surface clogs and the rate of wastewater infiltration is reduced below the percolative capacity of the surrounding soil. Therefore, the infiltrative surface must be sized on the basis of the expected hydraulic conductivity of the clogging mat and the estimated daily wastewater flow (see Chapter 4).

Direct measurement of the expected wastewater infiltration rate through a mature clogging mat in a specific soil cannot be done prior to design. However, experience with operating subsurface soil absorption systems has shown that design loadings can sometimes be correlated with soil texture (3)(4)(11)(12). Recommended rates of application versus soil textures and percolation rates are presented in Table 7-2. This table is meant only as a guide. Soil texture and measured percolation rates will not always be correlated as indicated, due to differences in structure, clay mineral content, bulk densities, and other factors in various areas of the country (see Chapter 3).

TABLE 7-1

SITE CRITERIA FOR TRENCH AND BED SYSTEMS

<u>Item</u>	<u>Criteria</u>
Landscape Position ^a	Level, well drained areas, crests of slopes, convex slopes most desirable. Avoid depressions, bases of slopes and concave slopes unless suitable surface drainage is provided.
Slope ^a	0 to 25%. Slopes in excess of 25% can be utilized but the use of construction machinery may be limited (7). Bed systems are limited to 0 to 5%.
Typical Horizontal Separation Distances ^b	
Water Supply Wells	50 - 100 ft
Surface Waters, Springs	50 - 100 ft
Escarpments, Manmade Cuts	10 - 20 ft
Boundary of Property	5 - 10 ft
Building Foundations	10 - 20 ft
Soil	
Texture	Soils with sandy or loamy textures are best suited. Gravelly and cobbly soils with open pores and slowly permeable clay soils are less desirable.
Structure	Strong granular, blocky or prismatic structures are desirable. Platy or unstructured massive soils should be avoided.
Color	Bright uniform colors indicate well-drained, well-aerated soils. Dull, gray or mottled soils indicate continuous or seasonal saturation and are unsuitable.

TABLE 7-1 (continued)

<u>Item</u>	<u>Criteria</u>
Layering	Soils exhibiting layers with distinct textural or structural changes should be carefully evaluated to insure water movement will not be severely restricted.
Unsaturated Depth	2 to 4 ft of unsaturated soil should exist between the bottom of the system and the seasonally high water table or bedrock (3)(4)(8).
Percolation Rate	1-60 min/in. (average of at least 3 percolation tests). ^c Systems can be constructed in soils with slower percolation rates, but soil damage during construction must be avoided.

^a Landscape position and slope are more restrictive for beds because of the depths of cut on the upslope side.

^b Intended only as a guide. Safe distance varies from site to site, based upon topography, soil permeability, ground water gradients, geology, etc.

^c Soils with percolation rates <1 min/in. can be used for trenches and beds if the soil is replaced with a suitably thick (>2 ft) layer of loamy sand or sand.

TABLE 7-2

RECOMMENDED RATES OF WASTEWATER APPLICATION
FOR TRENCH AND BED BOTTOM AREAS (4)(11)(12)^a

<u>Soil Texture</u>	<u>Percolation Rate</u> min/in.	<u>Application Rate^b</u> gpd/ft ²
Gravel, coarse sand	<1	Not suitable ^c
Coarse to medium sand	1 - 5	1.2
Fine sand, loamy sand	6 - 15	0.8
Sandy loam, loam	16 - 30	0.6
Loam, porous silt loam	31 - 60	0.45
Silty clay loam, clay loam ^d	61 - 120	0.2 ^e

^a May be suitable estimates for sidewall infiltration rates.

^b Rates based on septic tank effluent from a domestic waste source. A factor of safety may be desirable for wastes of significantly different character.

^c Soils with percolation rates <1 min/in. can be used if the soil is replaced with a suitably thick (>2 ft) layer of loamy sand or sand.

^d Soils without expandable clays.

^e These soils may be easily damaged during construction.

Conventional trench or bed designs should not be used for rapidly permeable soils with percolation rates faster than 1 min/in. (0.4 min/cm) (11). The rapidly permeable soils may not provide the necessary treatment to protect the groundwater quality. This problem may be overcome by replacing the native soil with a suitably thick (greater than 2 feet) layer of loamy sand or sand textured soil. With the liner in place, the design of the system can follow the design of conventional trenches and beds using an assumed percolation rate of 6 to 15 min/in. (2.4 to 5.9 min/cm).

Conventional trench or bed designs should also be avoided in soils with percolation rates slower than 60 min/in. (24 min/cm). These soils can be easily smeared and compacted during construction, reducing the soil's infiltration rate to as little as half the expected rate (12). Trench systems may be used in soils with percolation rates as slow as 120 min/in (47 min/cm), but only if great care is exercised during construction. Construction should proceed only when the soil is sufficiently dry to resist compaction and smearing during excavation. This point is reached when it crumbles when trying to roll a sample into a wire between the palms of the hands. Trenches should be installed so that construction machinery need not drive over the infiltrative surface. A 4- to 6-in. (10- to 15-cm) sand liner in the bottom of the trench may be used to protect the soil from compaction during placement of the aggregate and to expose infiltrative surface that would otherwise be covered by the aggregate (11)(13).

b. Geometry of the Infiltrative Surface

Sidewalls as Infiltrative Surfaces: Both the horizontal bottom area and the vertical sidewalls of trenches and beds can act as infiltrative surfaces. When a gravity-fed system is first put into service, the bottom area is the only infiltrative surface. However, after a period of wastewater application, the bottom can become sufficiently clogged to pond liquid above it, at which time the sidewalls become infiltrative surfaces as well. Because the hydraulic gradients and resistances of the clogging mats on the bottom and sidewalls are not likely to be the same, the infiltration rates may be different. The objective in design is to maximize the area of the surface expected to have the highest infiltration rate while assuring adequate treatment of wastewater and protection of the groundwater.

Because the sidewall is a vertical surface, clogging may not be as severe as that which occurs at the bottom surface, due to several factors: (1) suspended solids in the wastewater may not be a significant factor in sidewall clogging; (2) the rising and falling liquid levels in the system allow alternative wetting and drying of the sidewall while the bottom may remain continuously inundated; and (3) the clogging mat

can slough off the sidewall. These factors tend to make the sidewall clogging less severe than the bottom surface. However, the hydraulic gradient across the sidewall mat is also less. At the bottom surface, gravity, the hydrostatic pressure of the ponded water above, and the matric potential of the soil below the mat contribute to the total hydraulic gradient. At the sidewall, the gravity potential is zero, and the hydrostatic potential diminishes to zero at the liquid surface. Because the matric potential varies with changing soil moisture conditions, it is difficult to predict which infiltrative surface will be more effective.

In humid regions where percolating rainwater reduces the matric potential along the sidewall, shallow trench systems are suggested (4). The bottom area is the principal infiltrative surface in these systems. Shallow trenches often are best because the upper soil horizons are usually more permeable and greater evapotranspiration can occur. In dry climates, the sidewall area may be used to a greater extent. The bottom area may be reduced as the sidewall area is increased. Common practice is not to give credit to the first 6 in. (15 cm) of sidewall area measured from the trench bottom, but any exposed sidewall above 6 in. (15 cm) may be used to reduce the bottom area (3)(11). The infiltration rates given in Table 7-2 may be used for sidewall areas.

Trench versus Bed Design: Because beds usually require less total land area and are less costly to construct, they are often installed instead of trenches. However, trenches are generally more desirable than beds (4)(11)(12)(13)(14). Trenches can provide up to five times more sidewall area than do beds for identical bottom areas. Less damage is likely to occur to the soil during construction because the excavation equipment can straddle the trenches so it is not necessary to drive on the infiltrative surface. On sloping sites, trenches can follow the contours to maintain the infiltrative surfaces in the same soil horizon and keep excavation to a minimum. Beds may be acceptable where the site is relatively level and the soils are sands and loamy sands.

Shallow versus Deep Absorption Systems: Shallow soil absorption systems offer several advantages over deep systems. Because of greater plant and animal activity and less clay due to eluviation, the upper soil horizons are usually more permeable than the deeper subsoil. Also, the plant activity helps reduce the loading on the system during the growing season by transpiring significant amounts of liquid and removing some nitrogen and phosphorus from the waterwater. Construction delays due to wet soils are also reduced because the upper horizons dry more quickly.

On the other hand, deep systems have advantages. Increased depths permit increased sidewall area exposure for the same amount of bottom area. They also permit a greater depth of liquid ponding which increases the

hydraulic gradient across the infiltrative surface. In some instances, deep systems can be used to reach more permeable soil horizons when the proximity of groundwater tables do not preclude their use.

Freezing of shallow absorption systems is not a problem if kept in continuous operation (4)(11). Carefully constructed systems with 6 to 12 in. (15 to 30 cm) of soil cover, which are in continuous operation, will not freeze even in areas where frost penetration may be as great as 5 ft (1.5 m) if the distribution pipe is gravel packed and header pipes insulated where it is necessary for them to pass under driveways or other areas usually cleared of snow.

Alternating Systems: Dividing the soil absorption system into more than one field to allow alternate use of the individual fields over extended periods of time can extend the life of the absorption system. Alternating operation of the fields permits part of the system to "rest" periodically so that the infiltrative surface can be rejuvenated naturally through biodegradation of the clogging mat (4)(11)(12)(13)(15)(16). The "resting" field also acts as a standby unit that can be put into immediate service if a failure occurs in the other part of the system. This provides a period of time during which the failed field can be rehabilitated or rebuilt without an unwanted discharge.

Alternating systems commonly consist of two fields. Each field contains 50 to 100% of the total required area for a single field. Common practice is to switch fields on a semiannual or annual schedule by means of a diversion valve (see Figure 7-3 and Chapter 8). Though it has not yet been proven, such operation may permit a reduction in the total system size. In sandy soils with a shallow water table, the use of alternating beds may increase the chance of groundwater contamination because of the loss of treatment efficiency when the clogging mat is decomposed after resting.

c. Layout of the System

Location: Locating the area for the soil absorption system should be done with care. On undeveloped lots, the site should be located prior to locating the house, well, drives, etc., to ensure the best area is reserved. The following recommendations should be considered when locating the soil absorption system:

1. Locate the system where the surface drainage is good. Avoid depressions and bases of slopes and areas in the path of runoff from roofs, patios, driveways, or other paved areas unless surface drainage is provided.

FIGURE 7-3

ALTERNATING TRENCH SYSTEM WITH DIVERSION VALVE

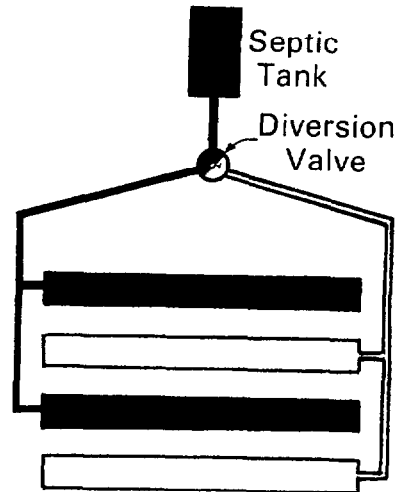

2. In areas with severe winters, avoid areas that are kept clear of snow. Automobiles, snowmobiles, and other vehicles should not be allowed on the area. Compacted or cleared snow will allow frost to penetrate the system, and compacted soil and loss of vegetation from traffic over the system will reduce evapotranspiration in the summer.
3. Preserve as many trees as possible. Trenches may be run between trees. Avoid damaging the trees during construction.

Configuration: Trenches should be used wherever possible. Not only do trenches perform better than beds, but they also conform to the site more easily. Trenches do not need to be straight, but should be curved to fit the contour of the lot or to avoid trees. A multi-trench system is preferable to a single trench because of the flexibility it offers in wastewater application.

On lots with insufficient area for trenches or on sites with granular soils, beds may be used. If only a sloping site exists, the bed should be constructed with long axes following the contour. However, beds should not be constructed on sites with slopes greater than 10% because the excavation becomes too deep on the upslope side. In such instances,

deep trenches with a greater depth of rock below the distribution pipe to increase the sidewall area is more suitable.

Reserve Area: When planning and locating the absorption system, consideration should be given to reserving a suitable area for construction of a second system. The second system would be added if the first were to fail or if the system required expansion due to increased wastewater flows. Care must be used in constructing the second system so that the original system is not damaged by the construction equipment.

The reserve area should be located to facilitate simultaneous or alternating loading of both systems. If the reserve area is used because the initial system has failed, the failing system should not be permanently abandoned. With time, the initial system will be naturally rejuvenated and can be used alternately with the reserve system. Reserve areas can be provided very easily with trench systems by reserving sufficient area between the initial trenches as shown in Figure 7-4.

Dimensions: The absorption system should be dimensioned to best fit the lot while maintaining separation distances and avoiding excessive depths of excavation. Commonly used dimensions are given in Table 7-3.

The depth of excavation is determined by the location of the most permeable soil horizon and flow restricting layers or the high water table elevation. Unless a deep, more permeable horizon exists, the trench or bed bottom elevation should be maintained at about 18 to 24 in. (46 to 61 cm) below the natural ground surface. To prevent freezing in cold climates, 6 to 12 in. (15 to 30 cm) of cover should be backfilled over the aggregate (11).

If the water table or a very slowly permeable layer is too near the ground surface to construct the system at this depth, the system can be raised. Very shallow trenches 6 to 12 in. (15 to 30 cm) deep can be installed and the area backfilled with additional soil (see Figure 7-5). Adequate separation distance must be provided between the trench bottom and the seasonally high groundwater level to prevent groundwater contamination.

The length of the trench or bed system depends on the site characteristics. The length of the distribution laterals is commonly restricted to 100 ft (30 m). This is based on the fears of root penetration, uneven settling, or pipe breakage which could disrupt the flow down the pipe to render the remaining downstream length useless. However, these fears are unwarranted because the aggregate transmits the wastewater (4)(13)(17). To assure adequate transmission and distribution of the

FIGURE 7-4

PROVISION OF A RESERVE AREA BETWEEN TRENCHES
OF THE INITIAL SYSTEM ON A SLOPING SITE

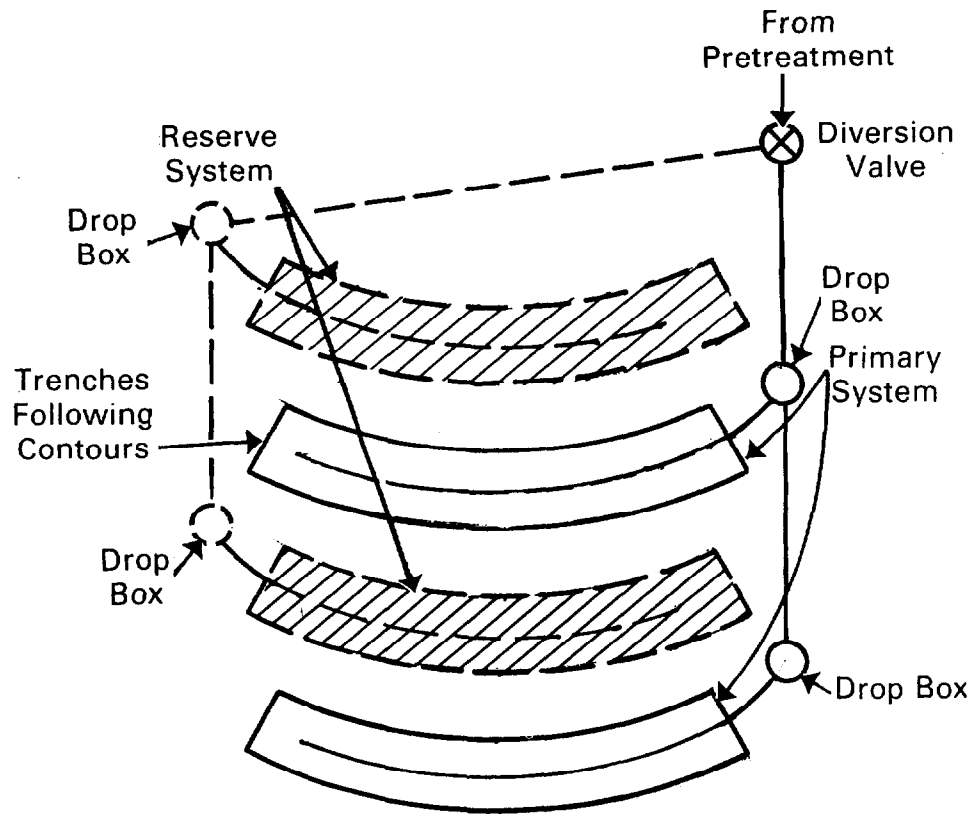

wastewater through the aggregate, extreme care must be taken to construct the trench bottom at the same elevation throughout its length. The overriding considerations for determining trench or bed lengths are the site characteristics.

Spacing between trench sidewalls could be as little as 18 in. (46 cm). A spacing of 6 ft (1.8 m) is suggested, however, to facilitate construction and to provide a reserve area between trenches.

TABLE 7-3
TYPICAL DIMENSIONS FOR TRENCHES AND BEDS

<u>System</u>	<u>Width</u> ft	<u>Length^b</u> ft	<u>Bottom</u> <u>Depth^c</u> ft	<u>Cover</u> <u>Thickness</u> in.	<u>Spacing^d</u> ft
Trenches	1-3 ^a	100	1.5-2.0	6 (min)	6
Beds	>3	100	1.5-2.0	6 (min)	6

^a Excavations generally should not be less than 1 ft wide because the sidewall may slough and infiltrate the aggregate(10)

^b Length of lateral from distribution inlet manifold. May be greater if site characteristics demand.

^c May be deeper if a more suitable horizon exists at greater depth and sufficient depth can be maintained between the bottom and seasonably high water table.

^d From sidewall to sidewall. Trench spacing may be decreased because of soil flow net patterns, specifically for shallow trenches in sandy soils.

FIGURE 7-5

TRENCH SYSTEM INSTALLED TO OVERCOME A SHALLOW WATER TABLE OR RESTRICTIVE LAYER [AFTER (11)]

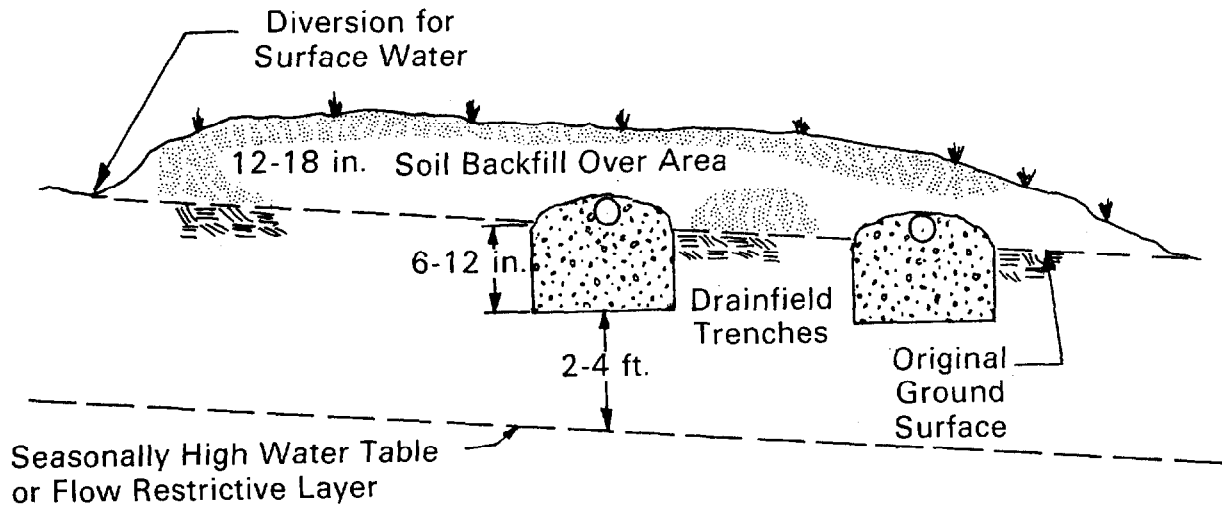

d. Effluent Distribution

Methods of Application: To ensure that the absorption system performs satisfactorily over a reasonably long lifetime, the method of wastewater application to the infiltrative surface must be compatible with the existing soil and site characteristics. Methods of wastewater application can be grouped into three categories: (1) gravity flow; (2) dosing; and (3) uniform application. For designs of distribution networks employing these methods, see Section 7.2.8)

1. Gravity flow is the simplest and most commonly employed of the distribution methods. Wastewater is allowed to flow into the absorption system directly from the treatment unit. With time, a clogging mat usually develops on the bottom surface of the absorption system and continuous ponding of the wastewater results. This may lead to more severe clogging of the soil, reducing the infiltration rate. However, this effect may be offset by the greater effective infiltrative area provided by submerging the sidewalls of the system, particularly in trench systems. The ponding also increases the hydraulic gradient

across the clogging mat, which can increase the infiltration rate (2)(18).

If adequate treatment is to be achieved in coarse granular soils such as sands, wastewater application by gravity flow requires that a clogging mat exist at the infiltrative surfaces to prevent saturated conditions in the underlying soil and to prevent groundwater contamination. The mat develops with continued application, but groundwater contamination by pathogenic organisms and viruses can be a danger at first.

2. Dosing can be employed to provide intermittent aeration of the infiltrative surface. In this method, periods of loading are followed by periods of resting, with cycle frequencies ranging from hours to days. The resting phase should be sufficiently long to allow the system to drain and expose the infiltrative surface to air, which encourages rapid degradation of the clogging materials by aerobic bacteria.

This method of operation may increase the rate of infiltration, as well as extend the life of the absorption system, because the clogging mat resistance is reduced (1)(4)(6)(15)(17). In sands or coarser textured materials, the rapid infiltration rates can lead to bacterial and viral contamination of shallow groundwater, especially when first put into use (4). Therefore, systems constructed in these soils should be dosed with small volumes of wastewater several times a day to prevent large saturated fronts moving through the soil. In finer textured soils, absorption, rather than treatment, is the concern. Large, less frequent doses are more suitable in these soils to provide longer aeration times between doses (4). See Table 7-4 for suggested dosing frequencies.

3. Uniform Application means applying the wastewater in doses uniformly over the entire bottom area of the system to minimize local overloading and the depth of ponding following each dose. This is usually achieved with a pressure distribution network. In this manner, the soil is more likely to remain unsaturated even during initial start-up when no clogging mat is present. The minimum depths of ponding during application permit rapid draining and maximum exposure of the bottom surface to air which reduces the clogging mat resistance. The sidewall is lost as an infiltrative surface, but this may be compensated for by the maintenance of higher infiltration rates through the bottom surface. See Table 7-4 for suggested dosing frequencies.

TABLE 7-4
DOSING FREQUENCIES FOR VARIOUS SOIL TEXTURES

<u>Soil Texture</u>	<u>Dosing Frequency</u>
Sand	4 Doses/Day
Sandy Loam	1 Dose/Day
Loam	Frequency Not Critical ^a
Silt Loam Silty Clay Loam	1 Dose/Day ^a
Clay	Frequency Not Critical ^a

^a Long-term resting provided by alternating fields may be desirable.

Selection of Application Method: The selection of an appropriate method of wastewater application depends on whether improved absorption or improved treatment is the objective. This is determined by the soil permeability and the geometry of the infiltrative surface. Under some conditions, the method of application is not critical, so selection is based on simplicity of design, operation, and cost. Methods of application for various soil and site conditions are summarized in Table 7-5. Where more than one may be appropriate, the methods are listed in order of preference.

e. Porous Media

The function of the porous media placed below and around the distribution pipe is four-fold. Its primary purposes are to support the distribution pipe and to provide a media through which the wastewater can flow from the distribution pipe to reach the bottom and sidewall infiltration areas. A second function is to provide storage of peak wastewater flows. Third, the media dissipates any energy that the incoming wastewater may have which could erode the infiltrative surface. Finally, the media supports the sidewall of the excavation to prevent its collapse.

TABLE 7-5
METHODS OF WASTEWATER APPLICATION FOR VARIOUS SYSTEM DESIGNS
AND SOIL PERMEABILITIES^a

<u>Soil Permeability (Percolation Rate)</u>	<u>Trenches or Beds (Fills, Drains) On Level Site</u>	<u>Trenches (Drains) On Sloping Site (>5%)</u>
Very Rapid (<1 min/in.)	Uniform Application ^b Dosing	Gravity Dosing
Rapid (1-10 min/in.)	Uniform Application Dosing Gravity	Gravity Dosing
Moderate (11-60 min/in.)	Dosing Gravity Uniform Application	Gravity Dosing
Slow (>60 min/in.)	Not Critical	Not Critical

^a Methods of application are listed in order of preference.

^b Should be used in alternating field systems to ensure adequate treatment.

The depth of the porous media may vary. A minimum of 6 in. (15 cm) below the distribution pipe invert and 2 in. (5 cm) above the crown of the pipe is suggested. Greater depths may be used to increase the sidewall area and to increase the hydraulic head on the infiltrative surface.

Gravel or crushed rock is usually used as the porous media, though other durable porous materials may be suitable. The suggested gravel or rock size is 3/4 to 2-1/2 in. (1.8 to 6.4 cm) in diameter. Smaller sizes are preferred because masking of the infiltrative surface by the rock is reduced (13). The rock should be durable and resistant to slaking and dissolution. A hardness of 3 or greater on the Moh's Scale of Hardness is suggested. Rock that can scratch a copper penny without leaving any residual rock meets this criterion. Crushed limestone is unsuitable unless dolomitic. The media should be washed to remove all fines that could clog the infiltrative surface.

To maintain the porous nature of the media, the media must be covered with a material to prevent backfilled soil from entering the media and filling the voids. Treated building paper was once used but has been abandoned in favor of untreated building paper, synthetic drainage fabric, marsh hay or straw. These materials do not create a vapor barrier and permit some moisture to pass through to the soil above where it can be removed through evapotranspiration. All these materials, except for the drainage fabric, will eventually decay. If they decay before the soil has stabilized, the value of the materials is lost. To ensure the barrier is not lost prematurely, heavy duty building paper of 40 to 60 lb (18 to 27 kg) weight or a 4 to 6 in. (10 to 15 cm) layer of marsh hay or straw should be used. In dry sandy soils, a 4 in. (10 cm) layer of hay or straw covered with untreated building paper is suggested to prevent the backfill from filtering down into the rock.

f. Inspection Pipes

Inspection pipes located in the subsurface soil absorption system provide limited access to observe the depth of ponding, a measure of the performance of the system, and a means of locating the subsurface field. If used, the inspection pipes should extend from the bottom infiltrative surface of the system up to or above final grade. The bottom should be open and the top capped. The portion of the pipe within the gravel should be perforated to permit a free flow of water (see Figure 7-6).

7.2.2.4 Construction

A frequent cause of early failure of soil absorption systems is the use of poor construction techniques. The following should be considered for construction of a soil absorption system:

a. Layout

The system should be laid out to facilitate the maneuvering of construction equipment so that damage to the soil is minimized.

1. Absorption system area should be staked out and roped off immediately after the site evaluation to keep construction equipment and other vehicles off the area until construction of the system begins.
2. Trenches rather than beds are preferable in soils with significant clay content (greater than 25% by weight) because equipment can straddle the trenches. This reduces the compaction and smearing at the exposed infiltrative surface.
3. Trenches should be spaced at least 6 ft (1.8 m) apart to facilitate the operation of the construction equipment if there is sufficient area.
4. To minimize sidewall compaction, trench widths should be made larger than the bucket used for excavation. Buckets are made to compact the sidewall to prevent caving during excavation. If the excavation is wider than the bucket, this effect is minimized. An alternative is to use modified buckets with side cutters or raker teeth (see Figure 7-7).
5. Trenches should follow the contour and be placed outside the drip lines of trees to avoid root damage.

b. Excavation

Absorption of waste effluent by soil requires that the soil pores remain open at the infiltrative surface. If these are sealed during construction by compaction, smearing, or puddling of the soil, the system may be rendered useless. The tendency toward compaction, smearing, and puddling depends upon the soil type, moisture content, and applied force.

FIGURE 7-6
TYPICAL INSPECTION PIPE

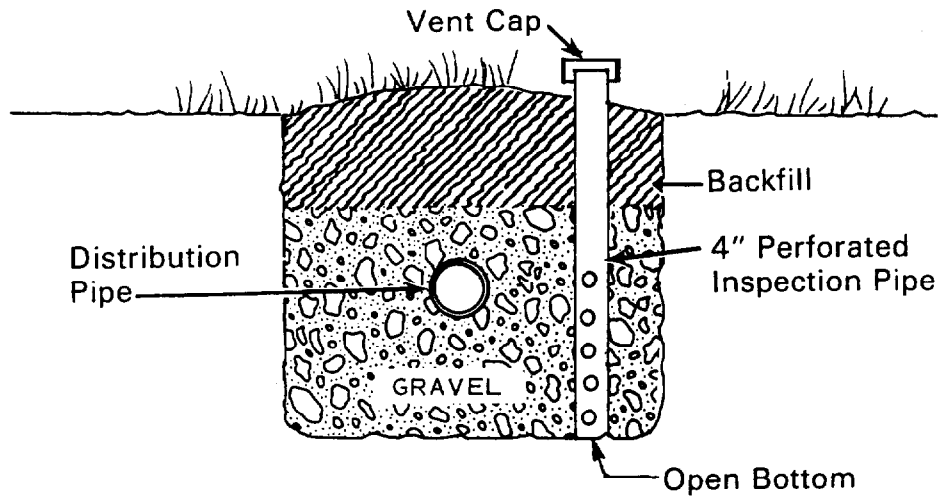
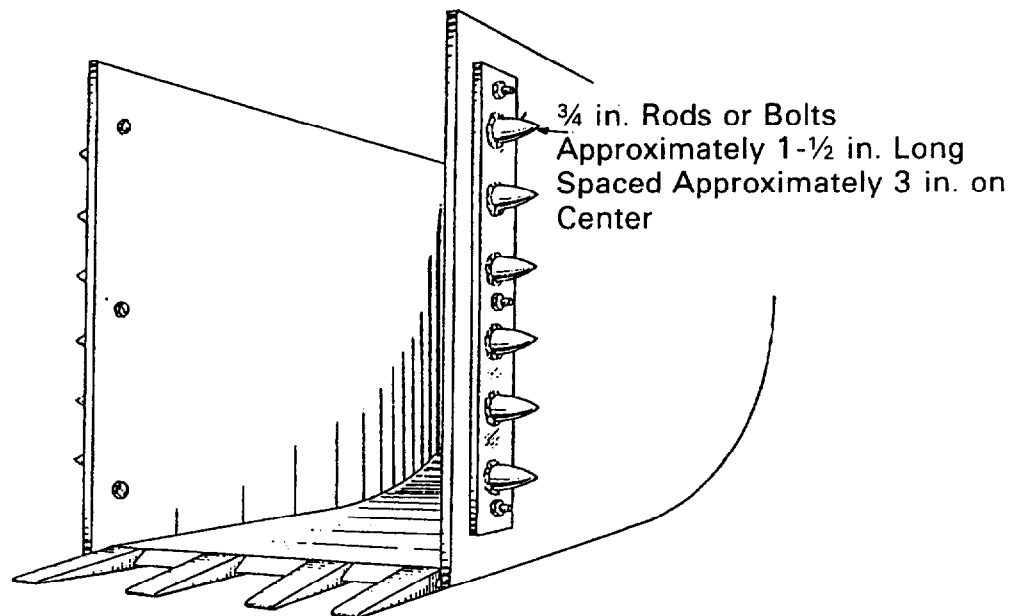

FIGURE 7-7
BACKHOE BUCKET WITH REMOVABLE RAKER TEETH (11)



Soils with high clay contents (greater than 25% by weight) are very susceptible to damage, while sands are rarely affected. Careful construction techniques minimize this soil damage. They include:

1. Excavation may proceed in clayey soils only when the moisture content is below the soil's plastic limit. If a sample of soil taken at the depth of the proposed bottom of the system forms a "wire" instead of crumbling when attempting to roll it between the hands, the soil is too wet.
2. A backhoe is usually used to excavate the system. Front-end loaders or bulldozer blades should not be used because the scraping action of the bucket or blade can smear the soil severely, and the wheels or tracks compact the exposed infiltrative surface.
3. Excavation equipment must not be driven on the bottom of the system. If trenches are used, the equipment can straddle the excavation. If a bed is used, the bed should be divided into segments so the machinery can always operate from undisturbed soil.
4. The bottom of each trench or bed must be level throughout to ensure more uniform distribution of effluent. A level and tripod are essential equipment.
5. The bottom and sidewalls of the excavation should be left with a rough open surface. Any smeared and compacted surfaces should be removed with care.
6. Work should be scheduled only when the infiltrative surface can be covered in one day, because wind-blown silt or raindrop impact can clog the soil.

c. Backfilling

Once the infiltrative surface is properly prepared, the backfilling operations must be done carefully to avoid any damage to the soil.

1. The gravel or crushed rock used as the porous media is laid in by a backhoe or front-end loader rather than dumped in by truck. This should be done from the sides of the system rather than driving out onto the exposed bottom. In large beds, the gravel or rock should be pushed out ahead of a small bulldozer.
2. The distribution pipes are covered with a minimum of 2 in. (5 cm) of gravel or rock to retard root growth, to insulate

against freezing and to stabilize the pipe before backfilling. Procedures for constructing the distribution network are discussed in Section 7.2.8.

3. The gravel or rock is covered with untreated building paper, synthetic drainage fabric, marsh hay or straw to prevent the unconsolidated soil cover from entering the media. The media should be covered completely. If untreated building paper is used, the seams should overlap at least 2 in. (5 cm) and any tears covered. If marsh hay or straw is used, it should be spread uniformly to a depth of 4 to 6 in. (10 to 15 cm). In bed construction, spreading a layer of hay or straw covered with untreated building paper is good practice.
4. The backfill material should be similar to the natural soil and no more permeable. It should be mounded above natural grade to allow for settling and to channel runoff away from the system.

7.2.2.5 Operation and Maintenance

a. Routine Maintenance

Once installed, a subsurface soil absorption system requires little or no attention as long as the wastewater discharged into it is nearly free of settleable solids, greases, fats, and oils. This requires that the pretreatment unit be maintained (see Chapter 6). To provide added insurance that the system will have a long, useful life, the following actions are suggested:

1. Resting of the system by taking it out of service for a period of time is an effective method of restoring the infiltration rate. Resting allows the absorption field to gradually drain, exposing the infiltrative surfaces to air. After several months, the clogging mat is degraded through biochemical and physical processes (1)(4)(6)(13)(15). This requires that a second absorption system exist to allow continued disposal, while the first is in the resting phase. The systems can be alternated on a yearly basis by means of a diversion valve (see Figure 7-3).
2. The plumbing fixtures in the home should be checked regularly to repair any leaks which can add substantial amounts of water to the system.
3. The use of special additives such as yeast, bacteria, chemicals, and enzyme preparations is not necessary and is of

little value for the proper function of the soil absorption system (3)(4).

4. Periodic application of oxidizing agents, particularly hydrogen peroxide, are being tried as a preventative maintenance procedure (19). If properly applied, the agents oxidize the clogging mat to restore much of the system's infiltration capacity within a day or two. Handling of these agents is very dangerous, and therefore the treatment should be done by trained individuals only. Experience with this treatment has been insufficient to determine its long-term effectiveness in a variety of soil types.

b. Rehabilitation

Occasionally, soil absorption systems fail, necessitating their rehabilitation. The causes of failure can be complex, resulting from poor siting, poor design, poor construction, poor maintenance, hydraulic overloading, or a combination of these. To determine the most appropriate method of rehabilitation, the cause of failure must be determined. Figure 7-8 suggests ways to determine the cause of failure and corresponding ways of rehabilitating the system.

The failure frequency should be determined before isolating the cause. Failure may occur occasionally or continuously. Occasional failure manifests itself with occasional seepage on the ground surface, sluggish drains, or plumbing backups. These usually coincide with periods of heavy rainfall or snowmelt. Continuous failure can have the same symptoms but on a continuous basis. However, some systems may seriously contaminate the groundwater with no surface manifestations of failure. These failures are detected by groundwater sampling.

Occasional Failure: The cause of occasional failure is much easier to determine, and rehabilitation can be more simple. Since the system functions between periods of failure, sizing and construction usually can be eliminated as the cause. In these instances, failure is the result of poor siting, poor maintenance, or hydraulic overloading. Excessive water use, plumbing leaks, or foundation drain discharges are common reasons for hydraulic overloading. These can be corrected by the appropriate action as indicated in Figure 7-8.

The next step is to investigate the site of the absorption system. Occasional failure usually is due to poor drainage or seasonally high water table conditions. The surface grading and landscape position should be checked for poor surface drainage conditions. Local soil conditions should also be investigated by borings for seasonally high

FIGURE 7-8

METHODS OF SOIL ABSORPTION FIELD REHABILITATION

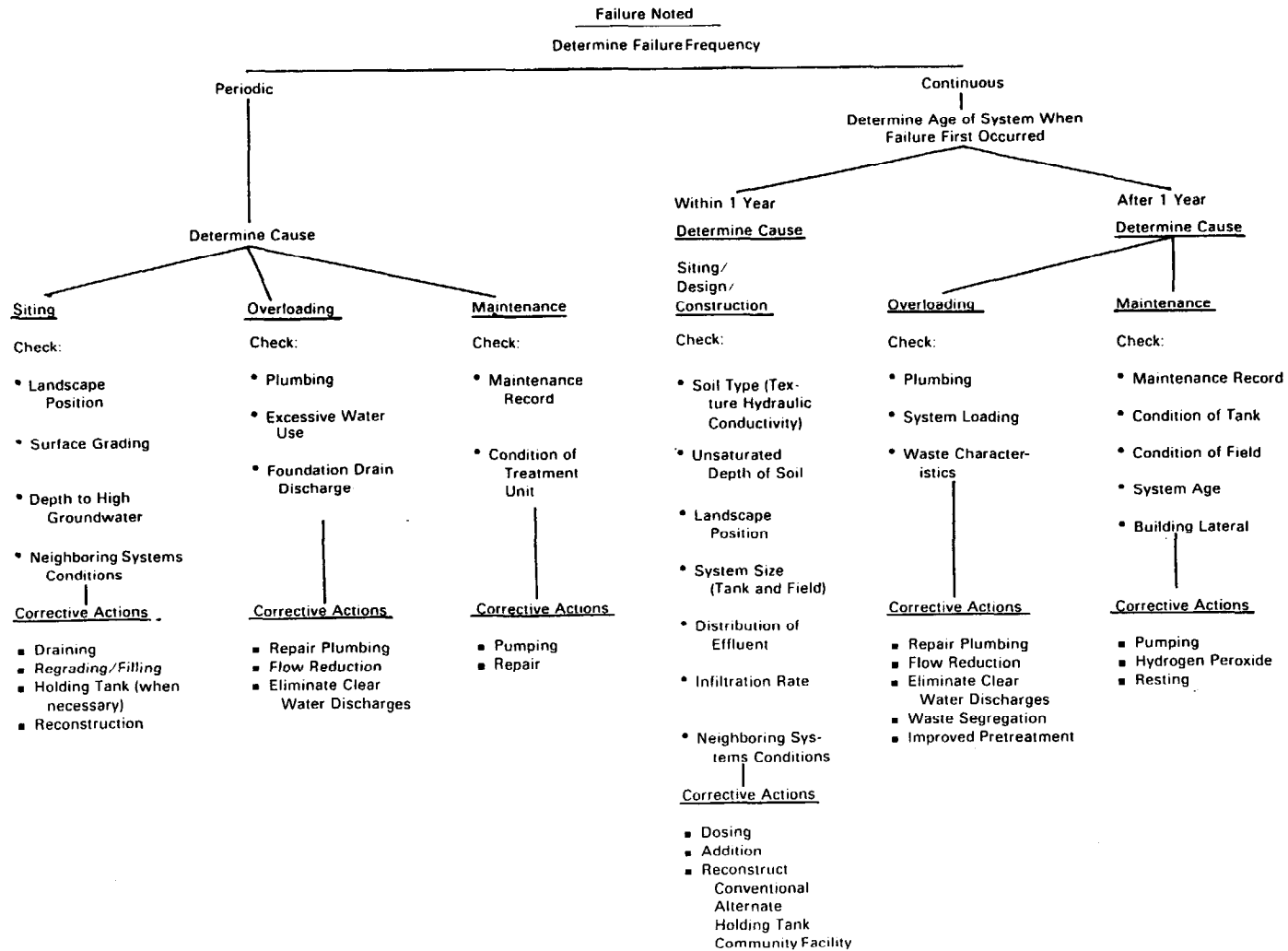

water tables (see Chapter 3). Corrective actions include improving surface drainage by regrading or filling low areas. High water table conditions may be corrected in some instances by installing drains (see Section 7.2.6).

Lack of maintenance of the treatment unit preceding the soil absorption field may also be a cause of occasional failure. The unit may be a point of infiltration and inflow during wet periods. The unit should be pumped and leaks repaired.

Continuous Failure: The causes of continuous failure are more difficult to determine. However, learning the age of the system when failure first occurred is very useful in isolating the cause.

If failure occurred within the first year of operation, the cause is probably due to poor siting, design, or construction. It is useful to check the performance of neighboring systems installed in similar soils. If they have similar loading rates and are working well, the failing system should be checked for proper sizing. A small system can be enlarged by adding new infiltration areas. In some instances, the sizing may be adequate but the distribution of the wastewater is poor due to improper construction. Providing dosing may correct this problem (see Section 7.2.8). Damage to the soil during construction may also cause failure, in which case the infiltrative area is less effective. Reconstruction or an addition is necessary. Alternate systems should be considered if the site is poor. This includes investigating the feasibility of a cluster or community system if surrounding systems are experiencing similar problems.

If the system had many years of useful service before failure occurred, hydraulic overloading or poor maintenance is usually the cause. The first step is to find out as much about the system as possible. A sketch of the system showing the size, configuration, and location should be made. A soil profile description should also be obtained. These items may be on file at the local regulatory agency but their accuracy should be confirmed by an onsite visit. If the system provided several years of useful service, evidences of overloading should be investigated first. Wastewater volume and characteristics (solids, greases, fats, oil) should be determined. Overloading may be corrected by repairing plumbing, installing flow reduction fixtures (see Chapter 5), and eliminating any discharges from foundation drains. If the volume reductions are insufficient for acceptance by the existing infiltrative surface, then additional infiltrative areas must be constructed. Systems serving commercial buildings may fail because of the wastewater characteristics. High solids concentrations or large amounts of fats,

oils, and greases, can cause failure. This is particularly true of systems serving restaurants and laundromats. These failures can be corrected by segregating the wastewaters to eliminate the troublesome wastewaters (see Chapter 5), or by improving pretreatment (see Chapter 6).

Lack of proper maintenance of the treatment unit may have resulted in excessive clogging due to poor solids removal by the unit. This can be determined by checking the maintenance record and the condition of the unit. If this appears to be the problem, the unit should be pumped and repaired, or replaced if necessary. The infiltrative surface of the absorption field should also be checked. If siting, design, or maintenance do not appear to be the cause of failure, excessive clogging is probably the problem. In such cases, the infiltrative surface can sometimes be rejuvenated by oxidizing the clogging mat (4)(9)(13)(16). This can be done by allowing the system to drain and rest for several months (4). To permit resting, a new system must be constructed with means provided for switching back and forth. Alternatively, the septic tank could be operated as a holding tank until the clogging mat has been oxidized. However, this involves frequent pumping, which may be costly. Another method, still in the experimental stage, is the use of the chemical oxidant, hydrogen peroxide (16). Because it is new, it is not known if it will work well in all soils. Extreme care should be used in its application because it is a strong oxidizing agent. Only individuals trained in its use should perform the treatment.

7.2.2.6 Considerations for Multi-Home and Commercial Wastewaters

Design of trench and bed soil absorption systems for small institutions, commercial establishments, and clusters of dwellings generally follows the same design principles as for single dwellings. In cluster systems serving more than about five homes, however, peak flow estimates can be reduced because of flow attenuation, but contributions from infiltration through the collection system must be included. Peak flow estimates should be based on the total number of people to be served (see Chapter 4). Rates of infiltration will vary with the type of collection sewer used (19)(20).

With commercial flows, the character of the wastewater is an important consideration. Proper pretreatment is necessary if the character is significantly different than domestic wastewater.

Flexibility in operation should also be incorporated into systems serving larger flows since a failure can create a significant problem. Alternating bed systems should be considered. A three-field system can be constructed in which each field contains 50% of the required absorption

area (19). This design allows flexibility in operation. Two beds are always in operation, providing 100% of the needed infiltrative surface. The third field is alternated in service on a semi annual or annual schedule. Thus, each field is in service for one or two years and "rested" for 6 months to one year to rejuvenate. The third field also acts as a standby unit in case one field fails. The idle field can be put into service immediately while a failed field is rehabilitated. Larger systems should utilize some dosing or uniform application to assure proper performance.

7.2.3 Seepage Pits

7.2.3.1 Description

Seepage pits or dry wells are deep excavations used for subsurface disposal of pretreated wastewater. Covered porous-walled chambers are placed in the excavation and surrounded by gravel or crushed rock (see Figure 7-9). Wastewater enters the chamber where it is stored until it seeps out through the chamber wall and infiltrates the sidewall of the excavation.

Seepage pits are generally discouraged by many local regulatory agencies in favor of trench or bed systems. However, seepage pits have been shown to be an acceptable method of disposal for small wastewater flows (21). Seepage pits are used where land area is too limited for trench or bed systems; and either the groundwater level is deep at all times, or the upper 3 to 4 ft (0.9 to 1.2 m) of the soil profile is underlain by a more permeable unsaturated soil material of great depth.

7.2.3.2 Site Considerations

The suggested site criteria for seepage pits are similar to those for trench and bed systems summarized in Table 7-1 except that soils with percolation rates slower than 30 min/in. (12 min/cm) are generally excluded. In addition, since the excavation sidewall is used as the infiltrative surface, percolation tests are run in each soil layer encountered. Maintaining sufficient separation between the bottom of the seepage pit and the high water table is a particularly important consideration for protection of groundwater quality.

FIGURE 7-9
SEEPAGE PIT CROSS SECTION

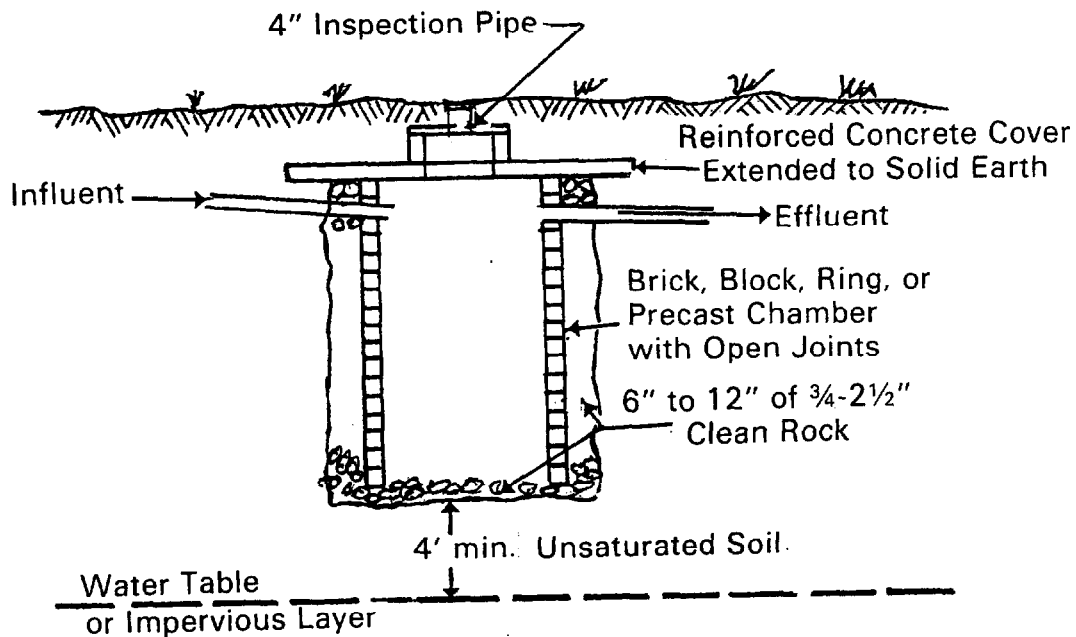

7.2.3.3 Design

a. Sizing the Infiltrative Surface

Since the dominant infiltration surface of a seepage pit is the sidewall, the depth and diameter of the pit is determined from the percolation rate and thickness of each soil layer exposed by the excavation. A weighted average of the percolation test results (sum of thickness times percolation rate of each layer divided by the total thickness) is used. Soil layers with percolation rates slower than 30 min/in. (12 min/cm) are excluded from this computation (3).

The weighted percolation rate is used to determine the required sidewall area. Infiltration rates presented previously in Table 7-2 are used with the estimated daily wastewater flow to compute the necessary sidewall area.

Table 7-6 can be used to determine the necessary seepage pit sidewall area for various effective depths below the seepage pit inlet.

TABLE 7-6
SIDEWALL AREAS OF CIRCULAR SEEPAGE PITS (ft²)^a

Seepage ^b Pit Diameter ft	Thickness of Effective Layers Below Inlet (ft)									
	1	2	3	4	5	6	7	8	9	10
1	3.1	6	9	13	16	19	22	25	28	31
2	6.3	13	19	25	31	38	44	50	57	63
3	9.4	19	28	38	47	57	66	75	85	94
4	12.6	25	38	50	63	75	88	101	113	126
5	15.7	31	47	63	79	94	110	126	141	157
6	18.8	38	57	75	94	113	132	151	170	188
7	22.0	44	66	88	110	132	154	176	198	220
8	25.1	50	75	101	126	151	176	201	226	251
9	28.3	57	85	113	141	170	198	226	254	283
10	31.4	63	94	126	157	188	220	251	283	314
11	34.6	69	104	138	173	207	242	276	311	346
12	37.7	75	113	151	188	226	264	302	339	377

^a Areas for greater depths can be found by adding columns. For example, the area of a 5 ft diameter pit, 15 ft deep is equal to 157 + 79, or 236 ft.

^b Diameter of excavation.

b. System Layout

Seepage pits may be any diameter or depth provided they are structurally sound and can be constructed without seriously damaging the soil. Typically, seepage pits are 6 to 12 ft (1.8 to 3.6 m) in diameter and 10 to 20 ft (3 to 6 m) deep but pits 18 in. (0.5 m) in diameter and 40 ft (12 m) deep have been constructed (22). When more than one pit is required, experience has shown that a separation distance from sidewall to sidewall equal to 3 times the diameter of the largest pit should be maintained (3).

The same guidelines used in locating trenches and beds are used to locate seepage pits. Area should be reserved for additional pits if necessary.

7.2.3.4 Construction

Pits may be dug with conventional excavating equipment or with power augers. Particular care must be exercised to ensure that the soils are not too wet before starting construction. If powered bucket augers are used, the pits should be reamed to a larger diameter than the bucket to minimize compaction and smearing of the soil. Power screw augers should only be used in granular soils because smearing of the sidewall is difficult to prevent with such equipment.

To maximize wastewater storage, porous walled chambers without bottoms are usually used. Precast concrete seepage chambers may be used or the chambers may be constructed out of clay or concrete brick, block or rings. The rings must have notches in them to provide for seepage. Brick or block are laid without mortar, with staggered open joints. Hollow block may be laid on its side but a 4-in. (10-cm) wall thickness should be maintained. Large-diameter perforated pipe standing on end can be used in small diameter pits. Six to 12 in. (15 to 30 cm) of clean gravel or 3/4 to 2-1/2 in. (1.8 to 6.4 cm) crushed rock is placed at the bottom of the excavation prior to placement or construction of the chamber. This provides a firm foundation for the chamber and prevents bottom soil from being removed if the pit is pumped.

The chamber is constructed one to two feet smaller in diameter than the excavation. The annular space left between the wall of the chamber and the excavation is filled with clean gravel or crushed rock to the top of the chamber.

Covers of suitable strength to support the soil cover and any anticipated loads are placed over the chamber and extend at least 12 in. beyond the excavation. Access to the pit for inspection purposes can be provided by a manhole. If a manhole is used, it should be covered with 6 to 12 in. (15 to 30 cm) of soil. An inspection pipe can extend to ground surface. A noncorrosive, watertight cap should be used with the inspection pipe.

7.2.3.5 Maintenance

A well-designed and constructed seepage pit requires no routine maintenance. However, failure occasionally occurs. Pumping and resting is the only reasonable rehabilitation technique available.

7.2.4 Mound Systems

7.2.4.1 Description

The mound system was originally developed in North Dakota in the late 1940's where it became known as the NODAK disposal system (23). The mound was designed to overcome problems with slowly permeable soils and high water tables in rural areas. The absorption bed was constructed in coarse gravel placed over the original soil after the topsoil was removed. Monitoring of these systems revealed that inadequate treatment occurred before the groundwater was reached, and seepage often occurred during wet periods of the year. Successful modifications of the design were made to overcome these limitations (4). Mound systems are now used under a variety of conditions.

A mound system is a soil absorption system that is elevated above the natural soil surface in a suitable fill material. The purpose of the design is to overcome site restrictions that prohibit the use of conventional soil absorption systems (4)(24). Such restrictions are: (1) slowly permeable soils, (2) shallow permeable soils over creviced or porous bedrock, and (3) permeable soils with high water tables. In slowly permeable soils, the mound serves to improve absorption of the effluent by utilizing the more permeable topsoil and eliminating construction in the wetter and more slowly permeable subsoil, where smearing and compaction are often unavoidable. In permeable soils with insufficient depth to groundwater or creviced or porous bedrock, the fill material in the mound provides the necessary treatment of the wastewater (see Figure 7-10).

The mound system consists of: (1) a suitable fill material, (2) an absorption area, (3) a distribution network, (4) a cap, and (5) top soil (see Figure 7-11). The effluent is pumped or siphoned into the absorption area through a distribution network located in the upper part of the coarse aggregate. It passes through the aggregate and infiltrates the fill material. Treatment of the wastewater occurs as it passes through the fill material and the unsaturated zone of the natural soil. The cap, usually a finer textured material than the fill, provides frost protection, sheds precipitation, and retains moisture for a good vegetative cover. The topsoil provides a growth medium for the vegetation.

FIGURE 7-10
TYPICAL MOUND SYSTEMS

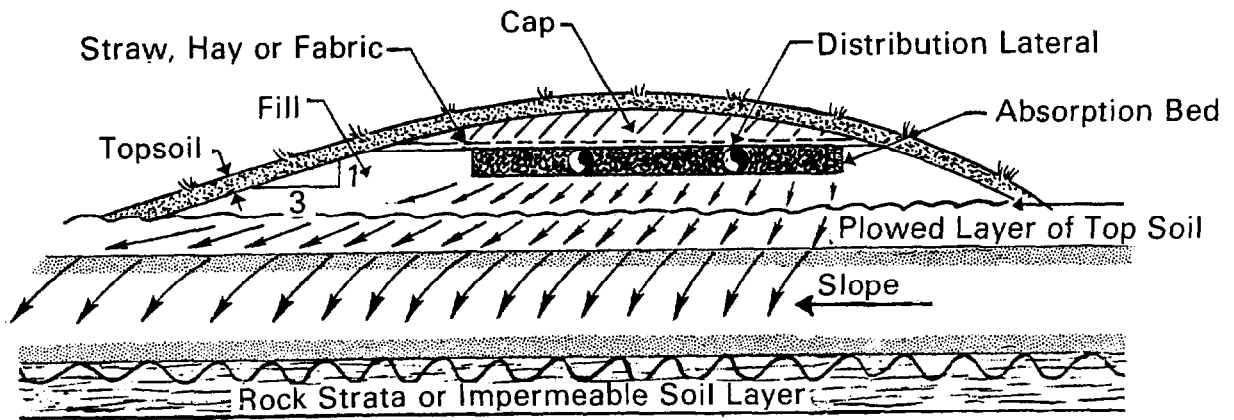

(a) Cross Section of a Mound System for Slowly Permeable Soil on a Sloping Site.

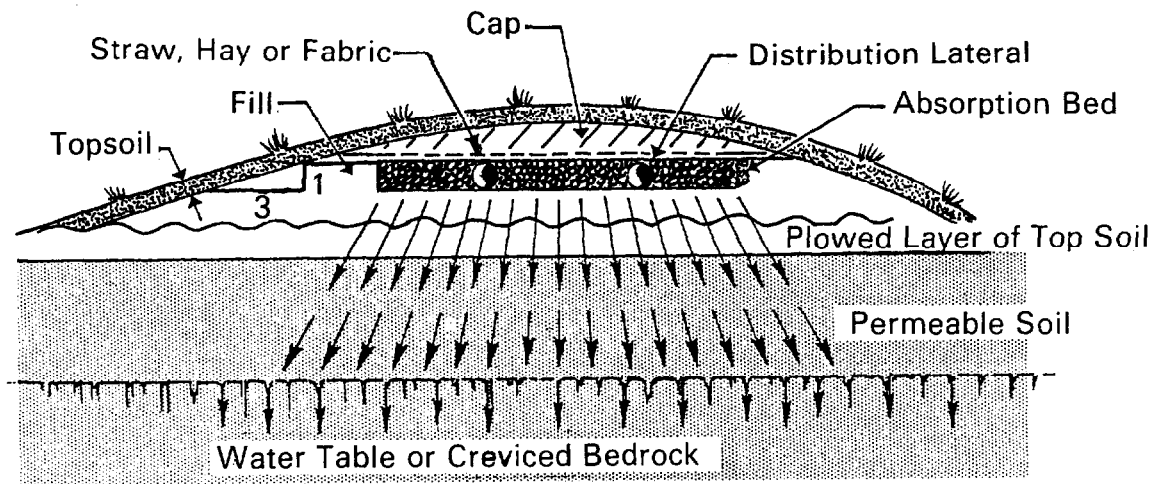

(b) Cross Section of a Mound System for a Permeable Soil, with High Groundwater or Shallow Creviced Bedrock

FIGURE 7-11

DETAILED SCHEMATIC OF A MOUND SYSTEM

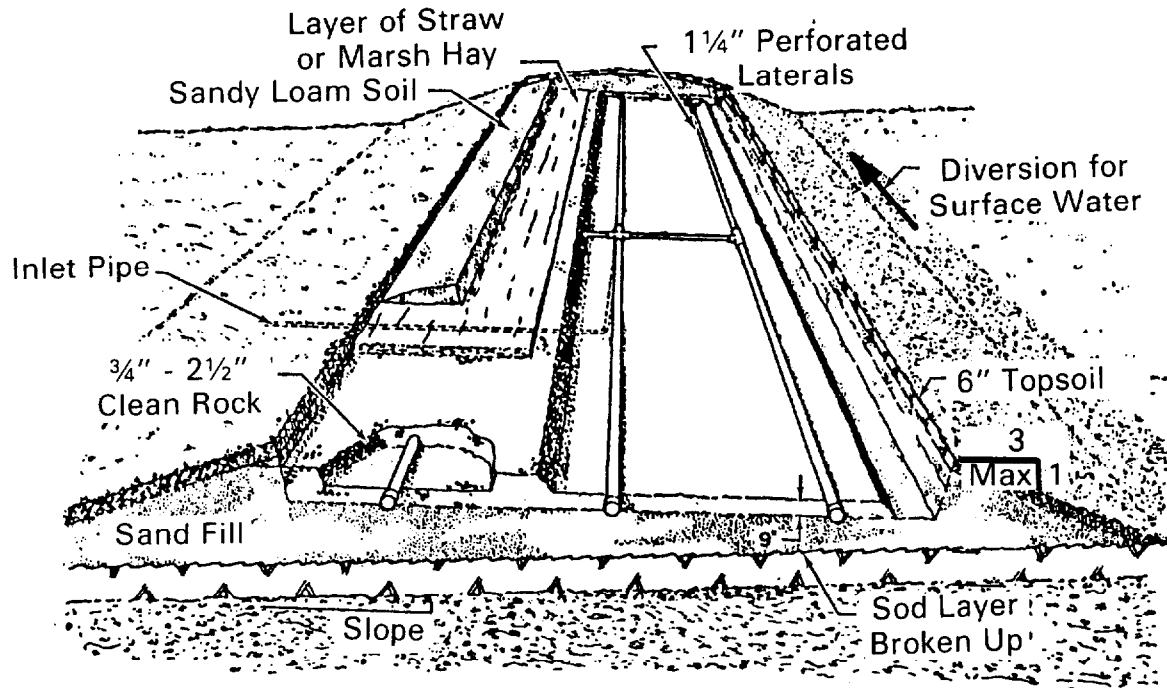

7.2.4.2 Application

a. Site Considerations

Site criteria for mound systems are summarized in Table 7-7. These criteria reflect current practice. Slope limitations for mounds are more restrictive than for conventional systems, particularly for mounds used on sites with slowly permeable soils. The fill material and natural soil interface can represent an abrupt textural change that restricts downward percolation, increasing the chance for surface seepage from the base of the mound.

TABLE 7-7
SITE CRITERIA FOR MOUND SYSTEMS

<u>Item</u>	<u>Criteria</u>
Landscape Position	Well drained areas, level or sloping. Crests of slopes or convex slopes most desirable. Avoid depressions, bases of slopes and concave slopes unless suitable drainage is provided.
Slope	0 to 6% for soils with percolation rates slower than 60 min/in. ^a 0 to 12% for soils with percolation rates faster than 60 min/in. ^a
Typical Horizontal Separation Distances from Edge of Basal Area	
Water Supply Wells	50 to 100 ft
Surface Waters, Springs	50 to 100 ft
Escarpments	10 to 20 ft
Boundary of Property	5 to 10 ft
Building Foundations	10 to 20 ft
	(30 ft when located upslope from a building in slowly permeable soils).
Soil	
Profile Description	Soils with a well developed and relatively undisturbed A horizon (topsoil) are preferable. Old filled areas should be carefully investigated for abrupt textural changes that would affect water movement. Newly filled areas should be avoided until proper settlement occurs.
Unsaturated Depth	20 to 24 in. of unsaturated soil should exist between the original soil surface and seasonally saturated horizons or pervious or creviced bedrock.

TABLE 7-7 (continued)

Depth to Impermeable Barrier	3 to 5 ft ^b
Percolation Rate	0 to 120 min/in. measured at 12 to 20 in. ^c

^a These are present limits used in Wisconsin established to coincide with slope classes used by the Soil Conservation Service in soil mapping. Mounds have been sited on slopes greater than these, but experience is limited (25).

^b Acceptable depth is site dependent.

^c Tests are run at 20 in. unless water table is at 20 in., in which case test is run at 16 in. In shallow soils over pervious or creviced bedrock, tests are run at 12 in.

The acceptable depth to an impermeable layer or rock strata is site specific. Sufficient depth must be available to channel the percolating wastewater away from the mound (see Figure 7-10). If not, the soil beneath the mound and the fill material may become saturated, resulting in seepage of effluent on the ground surface. The suggested depths to an impermeable layer given in Table 7-7 may be adjusted in accordance with the site characteristics. Soil permeability, climate, slope, and mound layout determine the necessary depth. Slowly permeable soils require a greater depth to remove the liquid than do permeable soils. Frost penetration reduces the effective depth and therefore a greater depth is required in areas with severe winters. Level sites require a greater depth because the hydraulic gradients in the lateral direction are less than on sloping sites. Finally, mound systems extended along the contour of a sloping site require less depth than a square mound. Not enough research information is available to give specific depths for these various conditions. Until further information is available, mounds on slowly permeable soils should be made as long as possible, with the restricting layer at least 3 ft (0.9 m) below the natural soil.

b. Influent Wastewater Characteristics

The wastewater entering the mound system should be nearly free from settleable solids, greases, and fats. Septic tanks are commonly used for pretreatment and have proved to be satisfactory. Water softener wastes are not harmful to the system nor is the use of common household chemicals and detergents (9)(10).

7.2.4.3 Design

a. Fill Selection

The mound design must begin with the selection of a suitable fill material because its infiltrative capacity determines the required absorption bed area. Medium texture sands, sandy loams, soil mixtures, bottom ash, strip mine spoil and slags are used or are being tested (24). To keep costs of construction to a minimum, the fill should be selected from locally available materials. Very permeable materials should be avoided, however, because their treatment capacity is less and there is a greater risk of surface seepage from the base of the mound when used over the more slowly permeable soils. Commonly used fill materials and their respective design infiltration rates are presented in Table 7-8.

TABLE 7-8
COMMONLY USED FILL MATERIALS AND THEIR
DESIGN INFILTRATION RATES (24)

<u>Fill Material</u>	<u>Characteristics^a</u>		<u>Design Infiltration Rate</u> gpd/ft ²
Medium Sand	>25%	0.25-2.0 mm	1.2
	<30-35%	0.05-0.25 mm	
	<5-10%	0.002-0.05 mm	
Sandy Loam	5-15%	Clay Content	0.6
Sand/Sandy Loam Mixture	88-93%	Sand	1.2
	7-12%	Finer Grained Material	
Bottom Ash	-	-	1.2

^a Percent by weight.

b. Geometry of the Absorption Bed

The absorption area within the mound system can either be a bed or a series of trenches. Beds are typically used for single homes or other small systems because they are easier to construct. The shape of the bed, however, depends on the permeability of the natural soil and the slope of the site. In most instances, a rectangular bed with the long axis parallel to the slope contour is preferred to minimize the risk of seepage from the base of the mound. If the natural soil has a percolation rate slower than 60 min/in. (24 min/cm), the bed should be made narrow and extended along the contour as far as possible (see Figure 7-12). In soils with percolation rates faster than 60 min/in. (24 min/cm), the bed can be square if the water table is greater than 3 ft (0.9 m) below the natural ground surface (4)(25).

FIGURE 7-12

PROPER ORIENTATION OF A MOUND SYSTEM ON A COMPLEX SLOPE

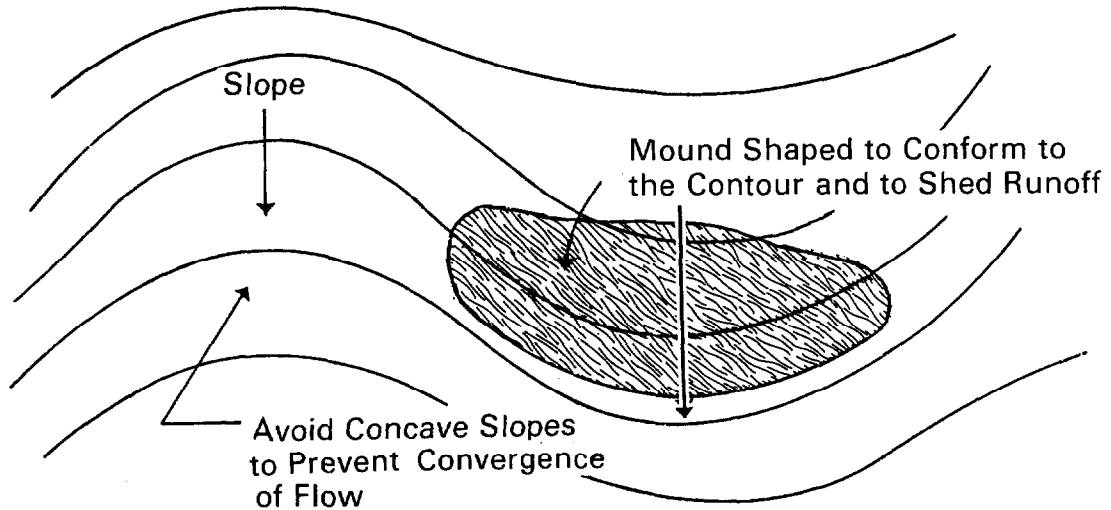

c. Sizing the Filled Area

The dimensions of the mound are dependent on the size and shape of the absorption bed, the permeability of the natural soil, the slope of the site, and the depth of fill below the bed (see Figure 7-13). Depths and dimensions are presented in Table 7-9.

The downslope setback (I) in Figure 7-13 is dependent on the permeability of the natural soil. The basal area of the mound must be sufficiently large to absorb the wastewater before it reaches the perimeter of the mound or surface seepage will result. On level sites, the entire basal area ($L \times W$) is used to determine I. However, on sloping sites, only the area below and downslope from the absorption bed is considered $[(B) \times (A + I)]$. The infiltrative rates used for the natural soil to size the downslope setback are given in Table 7-10. These rates assume that a clogging mat forms at the fill/natural soil interface, which may not be true. Since the percolating wastewater can and does move laterally from this area, these values are conservative. However, for soils with percolation rates faster than 60 min/in. (24 min/cm), the side slope criteria determine the basal area instead of the infiltration rate of

FIGURE 7-13
MOUND DIMENSIONS

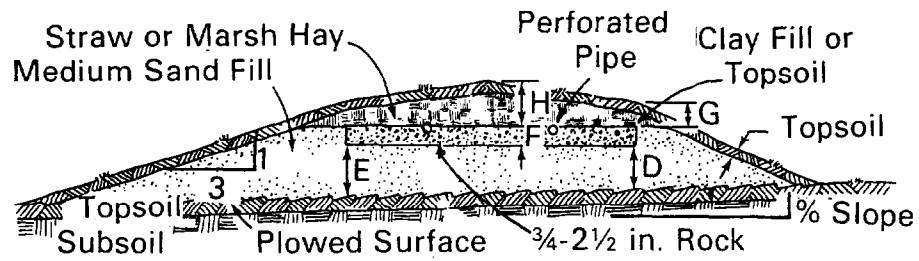

(A) Cross Section

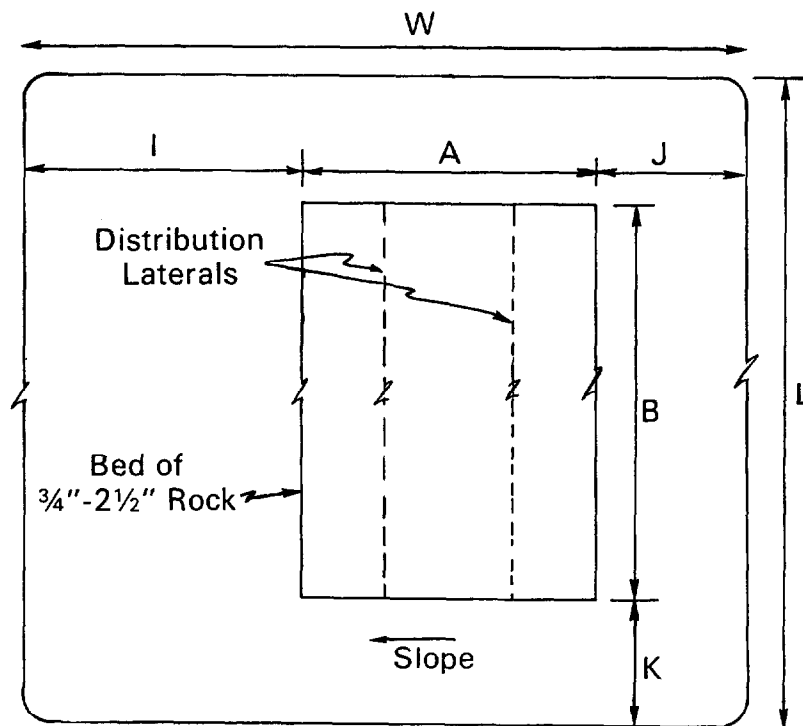

(B) Plan View

TABLE 7-9
DIMENSIONS FOR MOUND SYSTEMS^a (25)

<u>Item</u>	<u>Dimension</u>
Mound Height	
Fill Depth (D), ft	1 (min) ^b
Absorption Bed Depth (F), in.	9 (min)
Cap at Edge of Bed (G), ft	1 ^c
Cap at Center of Bed (H), ft	1.5 ^c
Mound Perimeter	
Downslope Setback (I)	Depends on Soil Permeability
Upslope Setback (J), ft	10 ^d
Side Slope Setback (K), ft	10 ^d
Side Slopes	No Steeper Than 3:1

^a Letters refer to lettered dimensions in Figure 7-13.

^b On sloping sites, this depth will increase downslope to maintain a level bed. In shallow soils where groundwater contamination is a concern, the fill depth should be increased to 2 ft.

^c A 4-6 in. depth of quality topsoil is included. This depth can be decreased by 6 in. in areas with mild winters. If depths less than 1 ft are used, erosion after construction must be avoided so sufficient soil covers the porous media.

^d Based on 3:1 side slopes. On sloping sites, (J) will be less if 3:1 side slope is maintained.

the top soil. It is only in the more slowly permeable soils where additional basal area is required, and a conservative design may be appropriate for these situations.

TABLE 7-10
INFILTRATION RATES FOR DETERMINING MOUND BASAL AREA (4)

<u>Natural Soil Texture</u>	<u>Percolation Rate</u> min/in.	<u>Infiltration Rate</u> gpd/ft
Sand, Sandy Loam	0-30	1.2
Loams, Silt Loams	31-45	0.75
Silt Loams, Silty Clay Loams	46-60	0.5
Clay Loams, Clay	61-120	0.25

d. Effluent Distribution

Although both gravity and pressure distribution networks have been used in mound systems, pressure distribution networks are superior (4)(24) (25). With pressure distribution, the effluent is spread more uniformly over the entire absorption area to minimize saturated flow through the fill and short circuiting, thus assuring good treatment and absorption. Approximately four doses per day is suggested (25). The design of pressure distributed networks is found in Section 7.2.8.

e. Porous Media

The porous media placed in the absorption bed of the mound is the same as described in Section 7.2.2.3.

f. Inspection Pipes

Inspection pipes are not necessary, but can be useful in observing ponding depths in the absorption bed (see Figure 7-6) of the mound.

Example 7.1: Calculation of Mound Dimensions and Pumping Requirements

Design a mound for a 3 bedroom house with the following site conditions. Letter notations used in Figure 7-13 are used in this example.

Natural Soil Texture: Clay loam
Percolation Rate at 20 in depth: 110 min/in.
Depth to Seasonally High Water Table: 20 in.
Slope: 6%
No bedrock or impermeable layers

Step 1: Select the Site. The mound site should be selected prior to locating the house and the road when possible. Consider all criteria listed in Table 7-7 for possible mound locations on the lot. Consider the difficulties in construction of the mound at the various locations. Evaluate all criteria, then pick the best site.

Step 2: Select Suitable Fill Material. It may be necessary to make a subjective judgement on the quality of fill material versus transportation costs. The ideal fill material may not be readily available and thus selection of lesser quality fill may be practical. If finer, the loading rates used to design the absorption bed may have to be reduced. Assume a medium texture sand for this example. The design infiltration rate is 1.2 gpd/ft² (Table 7-8).

Step 3: Estimate Design Flow. Peak flow is estimated from the size of the building. In this instance, 150 gpd/bedroom is assumed (see Chapter 4).

Step 4: Size Absorption Bed.

$$\text{Absorption Bed Area} = \frac{450 \text{ gpd}}{1.2 \text{ gpd/ft}^2} = 375 \text{ ft}^2$$

Step 5: Calculate Absorption Bed Dimension. The bed must parallel the site contour. Since the natural soil is slowly permeable, it is desirable to run the bed along the contour as far as possible. In this example, assume sufficient area exists for a 65-ft length bed.

$$\text{Bed Width (A)} = \frac{375 \text{ ft}^2}{65 \text{ ft}} = 5.8 \text{ ft or } 6 \text{ ft}$$

Bed Dimensions: A = 6 ft
B = 65 ft

Step 6: Calculate Mound Dimensions.

a. Mound Height

Fill Depth (D) = 1 ft (Table 7-9)

Fill Depth (E) = D + [(Slope) x (A)]

= 1 ft + [(0.06) x (6)]

= 1.4 ft (This is only approximate. Critical factor is construction of level bed bottom.)

Bed Depth (F) = 9 in. (min) (Table 7-9). (A minimum of 6 in. must be below the inverts of the distribution laterals.)

Cap at Edge of Bed (G) = 1 ft (min) (Table 7-9)

Cap at Center of Bed (H) = 1-1/2 ft (min) (Table 7-9)

b. Mound Perimeter

Downslope Setback (I): The area below and downslope of the absorption bed and sloping sites must be sufficiently large to absorb the peak wastewater flow. Select the proper natural soil infiltration rate from Table 7-10. In this case, the natural soil infiltration rate is 0.25 gpd/ft².

Upslope Setback (J) = (mound height at upslope edge of bed) x (3:1 slope)

= [(D) + (E) + (G)] x (3)

= (1.0 + 0.75 + 1.0) x (3)

= (2.75) x (3)

= 8.25 ft (This will be less because of natural ground slope, use 8 ft.)

Side Slope Setback (K) = (mound height at bed center) x (3:1 slope)

$$= \left[\frac{(D) + (E)}{2} + (F) + (H) \right] x (3)$$

$$\begin{aligned}
&= \left[\frac{1.0 + 1.4}{2} + 0.75 + 1.5 \right] \times (3) \\
&= (3.5) \times (3) \\
&= 10.5 \text{ ft, or } 11 \text{ ft}
\end{aligned}$$

$$\text{Basal Area Required} = (B) \times [(I) + (A)]$$

$$= \frac{450 \text{ gpd}}{0.25 \text{ gpd/ft}^2} = 1,800 \text{ ft}^2$$

$$(I) + (A) = \frac{1,800}{(B)}$$

$$(I) = \frac{1,800}{(B)} - (A)$$

$$= \frac{1,800}{65} - 6$$

$$= 21.7 \text{ ft, or } 22 \text{ ft}$$

Check to see that the downslope setback (I) is great enough so as not to exceed a 3:1 slope:

$$(\text{mound height at downslope edge of bed}) \times (3:1 \text{ slope})$$

$$= [(E) + (F) + (G)] \times (3)$$

$$= (1.4 + 0.75 + 1.0) \times (3)$$

$$= 9.5 \text{ ft}$$

Since the distance needed to maintain a 3:1 slope is less than the distance needed to provide sufficient basal area, (I) = 22 ft

$$\text{Mound Length (L)} = (B) + 2(K)$$

$$= 65 + 2(11)$$

$$= 87 \text{ ft}$$

$$\text{Mound Width (W)} = (J) + (A) + (I)$$

$$= 8 + 6 + 22$$

$$= 36 \text{ ft}$$

Step 7: Design Effluent Distribution Network. See Section 7.2.8(f).

7.2.4.4 Construction

a. Site Preparation

Good construction techniques are essential if the mound is to function properly. The following techniques should be considered:

- Step 1: Rope off the site to prevent damage to the area during other construction activity on the lot. Vehicular traffic over the area should be prohibited to avoid soil compaction.
- Step 2: Stake out the mound perimeter and bed in the proper orientation. Reference stakes set some distance from the mound perimeter are also required in case the corner stakes are disturbed.
- Step 3: Cut and remove any excessive vegetation. Trees should be cut at ground surface and the stumps left in place.
- Step 4: Measure the average ground elevation along the upslope edge of the bed to determine the bottom elevation of the bed.
- Step 5: Install the delivery pipe from the dosing chamber to the mound. Lay the pipe below the frost line or slope it uniformly back to the dosing chamber so it may drain after dosing. Back fill and compact the soil around the pipe.
- Step 6: Plow the area within the mound perimeter. Use a two bottom or larger moldboard plow, plowing 7 to 8 in. (18 to 20 cm) deep parallel to the contour. Single bottom plows should not be used, as the trace wheel runs in every furrow, compacting the soil. Each furrow should be thrown upslope. A chisel plow may be used in place of a moldboard plow. Roughening the surface with backhoe teeth may be satisfactory, especially in wooded sites with stumps. Rototilling is not recommended because of the damage it does to the soil structure. However, rototilling may be used in granular soils, such as sands.

Plowing should not be done when the soil is too wet. Smearing and compaction of the soil will occur. If a sample of the soil taken from the plow depth forms a wire when rolled between the palms, the soil is too wet. If it crumbles, plowing may proceed.

b. Fill Placement

- Step 1: Place the fill material on the upslope edges of the plowed area. Keep trucks off the plowed area. Minimize traffic on the downslope side.
- Step 2: Move the fill material into place using a small track type tractor with a blade. Always keep a minimum of 6 in. of material beneath the tracks of the tractor to minimize compaction of the natural soil. The fill material should be worked in this manner until the height of the fill reaches the elevation of the top of the absorption bed.
- Step 3: With the blade of the tractor, form the absorption bed. Hand level the bottom of the bed, checking it for the proper elevation. Shape the sides to the desired slope.

c. Distribution Network Placement

- Step 1: Carefully place the coarse aggregate in the bed. Do not create ruts in the bottom of the bed. Level the aggregate to a minimum depth of 6 in. (15 cm).
- Step 2: Assemble the distribution network on the aggregate. The manifold should be placed so it will drain between doses, either out the laterals or back into the pump chamber. The laterals should be laid level.
- Step 3: Place additional aggregate to a depth of at least 2 in. (5 cm) over the crown of the pipe.
- Step 4: Place a suitable backfill barrier over the aggregate.

d. Covering

- Step 1: Place a finer textured soil material such as clay or silt loam over the top of the bed to a minimum depth of 6 in. (15 cm).
- Step 2: Place 6 in. (15 cm) of good quality topsoil over the entire mound surface.
- Step 3: Plant grass over the entire mound using grasses adapted to the area. Shrubs can be planted around the base and up the sideslopes. Shrubs should be somewhat moisture tolerant since the downslope perimeter may become moist during early spring and late fall. Plantings on top of the mound should be drought

tolerant, as the upper portion of the mound can become dry during the summer.

7.2.4.5 Operation and Maintenance

a. Routine Maintenance

A properly designed and constructed mound should operate satisfactorily with virtually no regular maintenance.

b. Rehabilitation

Three failure conditions may occur within the mound. They are (1) severe clogging at the bottom of the absorption area, (2) severe clogging at the fill material and natural soil interface, and (3) plugging of the distribution network. Usually these failures can be easily corrected.

If severe clogging occurs at the bottom of the absorption bed, its cause should first be determined. If it is due to failure to maintain the pretreatment unit, hydrogen peroxide to oxidize the accumulated organics at the infiltrative surface could be used. The chemical can be applied directly to the bed or through the dosing chamber. Because of the danger in handling this strong oxidant, this treatment should be done by professionals.

If the clogging is due to overloading or unusual wastewater characteristics, efforts should be made to reduce the wastewater volume or strength. It may be necessary to enlarge the mound. The mound cap should be removed and the aggregate in the absorption bed stripped out. The area downslope of the mound should be plowed and additional fill added to enlarge the mound to the proper size. The absorption bed can then be reconstructed.

Severe clogging at the fill and natural soil interface will cause surface seepage at the base of the mound. This area should be permitted to dry and the downslope area plowed. Additional fill can then be added. If this does not correct the problem, the site may have to be abandoned.

Partial plugging of the distribution piping may be detected by extremely long dosing times. The ends of the distribution laterals should be exposed and the pump activated to flush out any solid material. If necessary, the pipe can be rodded.

7.2.4.6 Considerations for Multi-Home and Commercial Wastewaters

Designs of the mound system for larger flows follow the same design principles as for smaller flows. In cluster systems serving more than five homes, however, peak flow estimates can be reduced because of flow attenuation, but contributions from infiltration through the collection system must be included. Peak flow estimates should be based on the total number of people to be served (see Chapter 4). Rates of infiltration vary with the type of collection sewer used (19)(20).

With commercial flows, the character of the wastewater is an important consideration. Proper pretreatment is necessary if the character is significantly different than domestic wastewater.

Modifications to the design of the mound system may be desirable for larger flows on sloping sites or in slowly permeable soils. In both instances, the absorption area should be broken up into a series of trenches or smaller beds. This is beneficial on sloping sites because the beds can be tiered to reduce the amount of fill required (see Figure 7-14). Depths of fill material below beds should not exceed 4 to 5 ft (1.3 to 1.7 m) because differential settling will cause the bed to settle unevenly. If the system is tiered, each trench or bed must be dosed individually. This can be done by automatic valving or alternating pumps or siphons.

In sites with slowly permeable soils, breaking the absorption area into smaller trenches or beds helps distribute the effluent over much wider areas. Spacing of the beds or trenches should be sufficient so that the wastewater contributed from one trench or bed is absorbed by the natural soil before it reaches the lower trench or bed (see Table 7-10). The beds or trenches should be as long as the site allows. A long bed, broken into several shorter systems, each served by a pump or siphon, is preferred over two or more short parallel beds, especially in soils where the effluent moves downslope.

Flexibility in operation should also be incorporated into systems serving larger flows, since a failure can create a significant problem. Alternating bed systems should be considered. A three-bed system is suggested where each bed contains 50% of the required absorption area (19). Two beds are always in operation, providing 100% of the needed infiltrative surface. The third bed is alternated into service on a yearly schedule. Thus, each field is in service for two years and "rested" for one year to rejuvenate. The third bed also acts as a standby unit in case one bed fails. The idle fields can be put into service immediately while the failed bed is rehabilitated.

FIGURE 7-14
TIERED MOUND SYSTEM

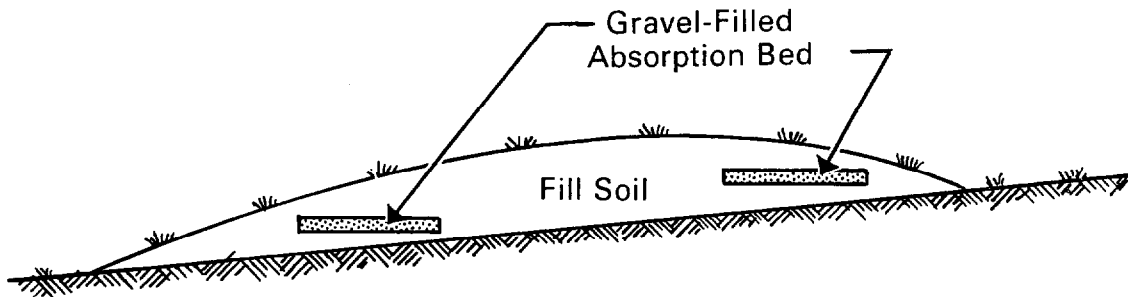

7.2.5 Fill Systems

7.2.5.1 Description

Fill systems may be used on sites with slowly permeable soils overlying sands and sandy loams where construction of a conventional system below the tight soil horizons may be ruled out. If the depth from the top surface of the underlying sand or sandy loam to the seasonally high water table or bedrock is inadequate to construct a trench or bed system, the slowly permeable soil may be stripped away and replaced with a sandy fill material to provide 2 to 4 ft (0.6 to 1.2 m) of unsaturated soil. A trench or bed system may then be constructed within the fill.

Mound systems would also be suitable designs for these conditions and may be less expensive to construct, but fill systems offer some advantages. If the soils overlying the sands or sandy loams are very slowly permeable, the size of a fill system may be smaller than that of a mound permitting their installation in smaller areas. Also, fill systems usually have less vertical relief above the natural grade than do mounds. This may be desirable for landscaping purposes.

7.2.5.2 Application

a. Site Considerations

The use of fills is restricted to sites where unsuitable surface soils may be stripped away without damaging the underlying soils. Therefore, fills are limited to sites where the underlying soils are sands or sandy loams and the seasonally high water table or bedrock surface is not within 1 ft (0.3 m) of the sand or sandy loam surface. If the depth to the seasonally high water table or bedrock is greater than 3 to 5 ft (0.9 to 1.5 m) from the sandy or sandy loam surface, a fill system is not necessary. A deep trench or bed system can be constructed directly in the more permeable underlying area.

Once the fill is placed, the site must meet all the site and soil criteria required for trench or bed systems (see Table 7-1).

b. Influent Wastewater Characteristics

The influent wastewater must be free of settleable solids, fats, and grease. Water softener wastes are not harmful, nor is the normal use of household chemicals and detergents.

7.2.5.3 Design

Since fill systems differ from trench and bed systems only in that they are constructed in a filled area, the design of fill systems is identical to trenches and beds. The only unique features are the sizing of the area to be filled and the fill selection. Uniform distribution of the wastewater over the infiltrative surface through a pressurized network is suggested to maintain groundwater quality (11).

a. Sizing of the Filled Area

A minimum separation distance of 5 ft (1.5 m) between the sidewalls of the absorption trenches or bed, and the edge of the filled area should be maintained. This allows for sidewall absorption and lateral movement of the wastewater.

If a perched water table condition occurs in the surface soils that are to be moved, provisions should be made to prevent this water from flowing into the filled area. Curtain drains, perimeter drains or barrier trenches may be necessary upslope or around the filled area to remove this water (see Section 7.2.6).

b. Fill Selection

The fill material should be similar in texture to the underlying sand or loamy sand. The backfill material used to cover the system should be finer textured to shed surface runoff. It may be the original soil that was removed.

7.2.5.4 Construction

Care should be exercised in removing the unsuitable soil prior to filling to prevent excessive disturbance of the sandy soil below. The machinery should always operate from unexcavated areas. The top few inches of the sand or sandy loam soil should be removed to ensure that all the unsuitable soil is stripped.

The exposed surface should be harrowed or otherwise broken up to a depth of 6 in. (15 cm) prior to filling. This eliminates a distinct interface forming between the fill and the natural soil that would disrupt liquid movement.

Once the fill has been placed, construction of the absorption system can proceed as for trenches or beds in sands. However, if the fill depth is greater than 4 ft (1.2 m), the fill should be allowed to settle before construction begins. This may require a year to settle naturally. To avoid this delay, the fill can be spread in shallow lifts and each mechanically compacted. This must be done carefully, however, so that layers of differing density are not created. The fill should be compacted to a density similar to the underlying natural soil.

7.2.5.5 Operation and Maintenance

The operation and maintenance of fill systems are identical to trenches and beds constructed in sands. The fill system lends itself very well to treatment with chemical oxidants or reconstruction in the same area.

7.2.6 Artificially Drained Systems

7.2.6.1 Description

High water tables that limit the use of trenches, beds or seepage pits can sometimes be artificially lowered to permit the use of these disposal methods. Vertical drains, curtain drains and underdrains are commonly used subsurface drainage techniques. Soil and site conditions determine which method is selected.

Curtain drains and vertical drains are used to lower perched water tables. These methods are most effective where the perched water is moving laterally under the soil absorption site. The drains are placed upstream of the absorption area to intercept the groundwater as it flows into the area.

Curtain drains are trench excavations in which perforated drainage pipe is placed. These are placed around the upslope perimeter of the soil absorption site to intercept the groundwater moving into the area (see Figure 7-15). If the site has sufficient slope, the drains are brought to the surface downslope to allow free drainage. On level sites, pumps must be used to remove the collected water. If the restrictive layer that creates the water table is thin and overlies permeable soil, vertical drains may be used. These are trench excavations made through the restrictive layer into the more permeable soil below and backfilled with porous material (see Figure 7-16). Thus, water moving toward the excavation is able to drain into the underlying soil. Vertical drains are susceptible to sealing by fine sediment transported by the water.

Underdrains are used where water tables exist 4 to 5 ft (1.2 to 1.5 m) below the surface in permeable soils. The drains are similar to curtain drains in construction, but several drains may be necessary to lower the water table sufficiently (see Figure 7-17). Depth and spacing of the drains are determined by the soil and water table characteristics.

7.2.6.2 Site Considerations

Successful design of artificially drained systems depends upon the correct diagnosis of the drainage problem. The source of the groundwater and its flow characteristics must be determined to select the proper method of drainage. Particular attention must be given to soil stratification and groundwater gradients.

FIGURE 7-15

CURTAIN DRAIN TO INTERCEPT LATERALLY MOVING PERCHED WATER TABLE CAUSED BY A SHALLOW, IMPERMEABLE LAYER

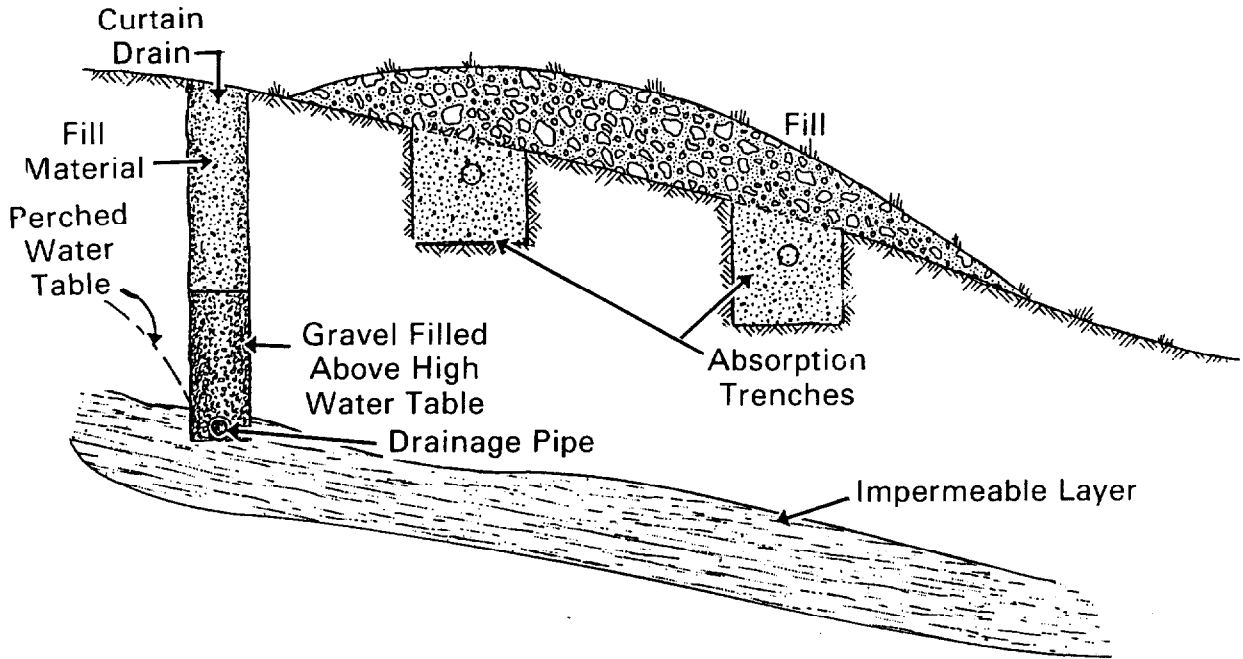

FIGURE 7-16

VERTICAL DRAIN TO INTERCEPT LATERALLY MOVING PERCHED WATER TABLE CAUSED BY A SHALLOW, THIN, IMPERMEABLE LAYER

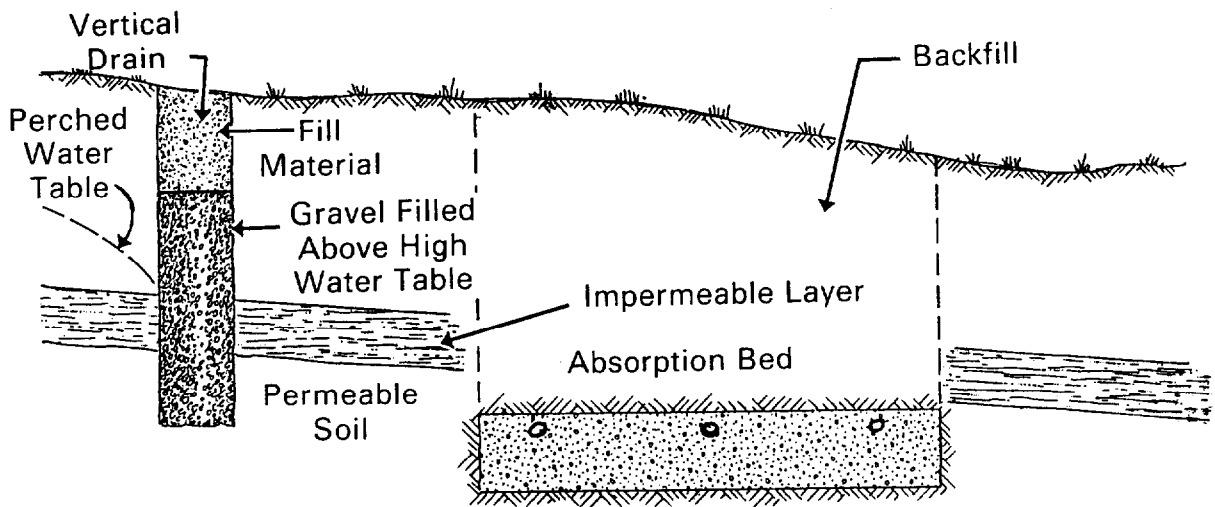
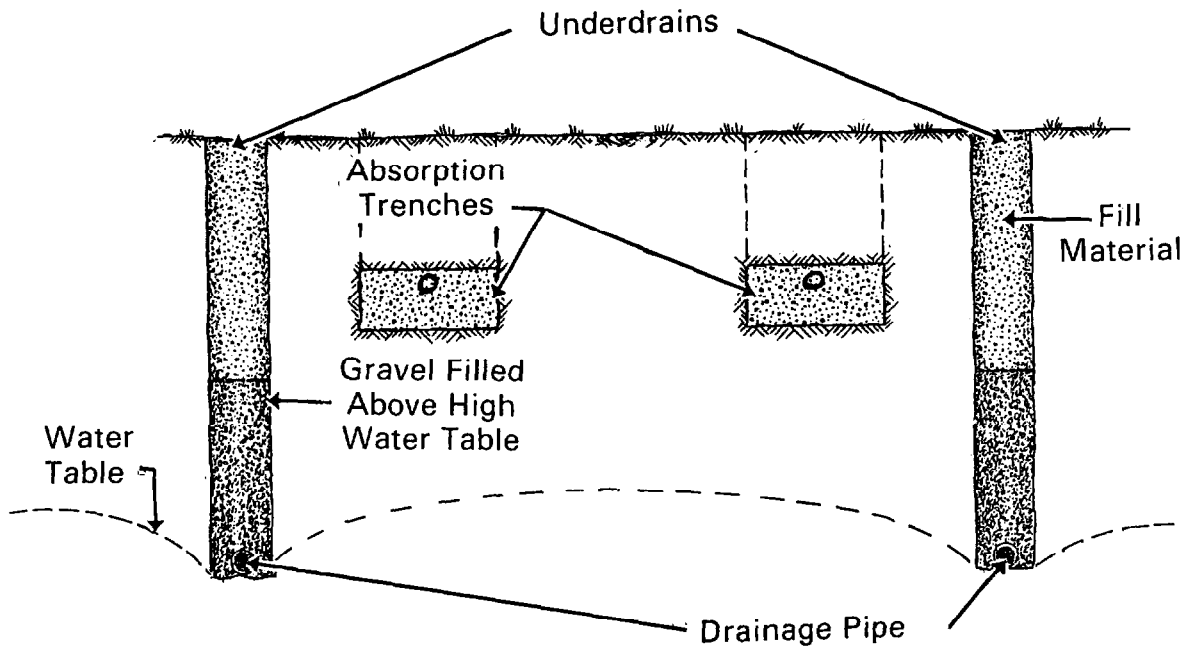

FIGURE 7-17
UNDERDRAINS USED TO LOWER WATER TABLE



a. Subsurface Drainage Problems

There is an unlimited variety of subsurface drainage problems but the most common ones can be grouped into four general types (26). These are: (1) free water tables, (2) water tables over artesian aquifers, (3) perched water tables, and (4) lateral groundwater flow problems.

Free water tables typically are large, slow moving bodies of water fed by surface waters, precipitation, and subsurface percolation from other areas. In the lower elevations of the drainage basin, the groundwater is discharged into streams, on the ground surface in low areas, or by escape into other aquifers. The groundwater elevation fluctuates seasonally. The slope of a free water table surface is usually quite gentle.

Where the soil is permeable, underdrains can be used to lower the water table sufficiently to permit the installation of trench or bed disposal systems. In fine textured soils of slow permeability, however, subsurface drainage is impractical.

An artesian aquifer is a groundwater body confined by an impervious layer over the aquifer. Its pressure surface (the elevation to which it would rise in a well tapping the aquifer) is higher than the local water table, and may even rise above the ground surface. Pressure in the aquifer is caused by the weight of a continuous body of water that is higher than the local water table. Leaks at holes or weak points in the confining layer create an upward flow, with the hydraulic head decreasing in the upward direction. The groundwater moves in the direction of the decreasing gradient and escapes as seepage at the ground surface or moves laterally into other aquifers.

Areas with this problem are impractical to drain. The water removed is continually replenished from the aquifer. This requires relatively deep and closely spaced drains and pumped discharges. Onsite disposal options other than soil absorption systems should be investigated in areas with shallow artesian aquifers.

In stratified soils, a water table may develop that is separated from the free water table by a slowly permeable layer, i.e., a perched water table. This occurs when surface sources of water saturate the soil above the layer due to slow natural drainage. Methods employed to drain perched water tables depend upon the particular site conditions. Vertical drains, curtain drains or underdrains may be used.

Lateral groundwater flow problems are characterized by horizontal groundwater movement across the area. This flow pattern is usually created by soil stratification or other natural barriers to flow.

The depth, orientation and inclination of the strata or barriers determine the drainage method used and its location. Curtain drains or vertical drains are usually employed to intercept the water upstream of the area to be drained.

b. Site Evaluation

Soils with high water tables that may be practical to drain to make a site suitable for a trench or bed system are ones having (1) shallow perched water tables, (2) lateral groundwater flow, or (3) free water tables in coarse textured soils. Soils that are saturated for prolonged

periods, particularly on level sites, are not practical to drain. Other disposal methods should be investigated for such sites.

Because each of these drainage problems require different solutions, it is important that the site evaluation be done in sufficient detail to differentiate between them. Where the need for subsurface drainage is anticipated, topographic surveys, soil profile descriptions and estimation of the seasonally high groundwater elevations and gradients should be emphasized. Evaluation of these site characteristics must be done in addition to other characteristics that are evaluated for subsurface disposal (see Chapter 3).

Topographic Surveys: Topographic maps of the site with 1 to 2 ft (0.3 to 0.6 m) contour intervals are useful as base maps on which water and soils information can be referenced. Water table elevations, seep areas and areas with vegetation indicative of seasonal or prolonged high water tables should be located on the map. Elevations of ridges, knolls, rock outcrops and natural drainage ways should also be noted. This information is useful in establishing the source of the groundwater, its direction of flow, and the placement of the drainage system.

Soil Profile Descriptions: The soil profile must be carefully examined to identify the type of drainage problem and the extent of seasonal water table fluctuations. Soil stratification and soil color are used to make these determinations.

Soil stratification or layering may or may not be readily visible. Soil texture, density, color, zones of saturation and root penetration aid in identifying layers of varying hydraulic conductivity (see Chapter 3). The thickness and slope of each layer should be described. Deep uniform soils indicate that the drainage problem must be handled as a free water table problem. Stratified soils indicate a perched or lateral flow groundwater problem.

The soil color helps to identify zones of periodic and continuous saturation. Soil mottling occurs when the soil is periodically saturated, and gleyed soil indicates continuous saturation (see Chapter 3). The highest elevation of the mottling provides an estimate of the seasonally high water table, while the top of the gleyed zone indicates the seasonally low water table elevation. It is particularly important to establish the extent of the seasonal fluctuations to determine if drainage is practical. If the seasonally low water table is above the elevation to which the soil must be drained to make the site acceptable, drainage must be provided throughout the year. If pumps are used to remove the water, costs may be excessive and other alternatives should be investigated.

Groundwater Elevation and Gradients: To accurately determine groundwater elevations and gradients, observation wells or piezometers are used. Observation wells are used to observe groundwater fluctuations throughout a year or more. If several are strategically placed about the area, the local gradient can also be established by measuring the water surface elevation in each well. Piezometers differ from observation wells in that they are constructed so that there is no leakage around the pipe. The water surface elevation measured establishes the hydrostatic pressure at the bottom of the well. If placed at several depths, they can be used to establish whether artesian conditions exist. For construction of piezometers and interpretation of results, see USDA, "Drainage of Agricultural Land" (26).

The measured or estimated water table elevations for a specific time period are plotted on the topographic map. By drawing the contours of the water table surface from these plots, the direction of groundwater movement is determined, since movement is perpendicular to the groundwater contours. This helps locate the source of the water and how to best place the drainage network.

7.2.6.3 Design

a. Selection of Drainage Method

In designing a subsurface drainage system, the site characteristics are evaluated to determine which method of drainage is most appropriate. Table 7-11 presents the drainage method for various site characteristics. In general, shallow, lateral flow problems are the easiest drainage problems to correct for subsurface wastewater disposal. Since the use of underdrains for onsite disposal systems has been very limited, other acceptable disposal methods not requiring drains should first be considered.

b. Curtain Drains

Curtain drains are placed some distance upslope from the proposed soil absorption system to intercept the groundwater, and around either end of the system to prevent intrusion. On sites with sufficient slope, the drain is extended downslope until it surfaces, to provide free drainage. The drain is placed slightly into the restrictive layer to ensure that all the groundwater is intercepted. A separation distance from the soil absorption system is required to prevent insufficiently treated wastewater from entering the drain. This distance depends on the soil permeability and depth of drain below the bottom of the absorption system; however, a separation distance of 10 ft is commonly used.

TABLE 7-11

DRAINAGE METHODS FOR VARIOUS SITE CHARACTERISTICS

<u>Site Characteristics</u>	<u>Drainage Problem</u>	<u>Drainage Method</u>
Saturated or mottled soils above a restrictive layer with water source located at a higher elevation; site usually sloping	Lateral flow	Curtain drain Vertical drain ^a
Saturated or mottled soils above a restrictive layer; soil below restrictive layer is unsaturated; site is level or only gently sloping	Perched water table	Underdrain ^b Vertical drain ^a
Deep uniform soils mottled or saturated	Free water table	Underdrain ^b
Saturated soils above and below restrictive layer with hydraulic gradients increasing with depth	Artesian-fed water table	Avoid

^a Use only where restrictive layer is thin and underlying soil is reasonably permeable.

^b Soils with more than 70% clay are difficult to drain and should be avoided.

The size of the drain is dependent upon the soil permeability, the size of the area drained, and the gradient of the pipe. Silt traps are sometimes provided in the drain to improve the quality of the discharged drainage. These units may require infrequent cleaning to maintain their effectiveness.

c. Vertical Drains

Vertical drains may be used to intercept a laterally flowing perched water table. Separation distances between the drain and the bottom of the soil absorption system are the same as for curtain drains to maintain an unsaturated zone under the absorption system.

The size and placement of the drain depends upon the relative permeabilities of the saturated soil and the soil below the restrictive layer, and the size of the area to be drained. The infiltration surface of the vertical drain (sidewalls and bottom area) must be sized to absorb all the water it receives. The width and depth of the drain below the restrictive layer is calculated by assuming an infiltration rate for the underlying soil. If clay and silt are transported by the groundwater, the infiltration rate will be less than the saturated conductivity of the soil. Clogging of the vertical drain by silt can be a significant problem. Unfortunately, experience with these drains in wastewater disposal is lacking.

d. Underdrains

Underdrains must be located to lower the water table to provide the necessary depth of unsaturated soil below the infiltrative surface of the soil absorption system, and to prevent poorly treated effluent from entering the drain. Sometimes, a network of drains is required throughout the area where the soil absorption system is located. The depth and spacing of the drains is determined by the soil permeability, the size of the area to be drained, and other factors. Where necessary, however, see USDA Drainage of Agricultural Land (26) for design procedures.

7.2.6.4 Construction

a. Curtain Drains and Underdrains

To maximize infiltration of the groundwater into the pipe, a coarse, porous material such as gravel, crushed rock, etc., should be placed under and above the pipe. The porous material is extended above the

high water table elevation. To prevent silt from entering the pipe while the disturbed area is stabilizing, the tops of the joints or perforations should be covered with waterproof building paper or the pipe jacketed with mesh. Natural soil material is used for the remainder of the backfill (27).

The outlet must be protected from small animals. The outlet may be covered with a porous material such as rock or gravel. Various commercial outlet protection devices are also available (26).

b. Vertical Drains

Vertical drains are dug to the desired depth and width, and are back-filled with a coarse, porous media such as coarse sand, 1/4- to 1/2-in (0.6 to 1.3 cm) gravel, or similar material, to a level above the high perched water table elevation. Natural soil materials are used for the remainder of the backfill.

7.2.6.5 Maintenance

A well-designed and constructed drainage system requires little maintenance. The outlets should be inspected routinely to see that free drainage is maintained. If a silt trap is used, it should be inspected annually to determine the need for cleaning.

7.2.7 Electro-Osmosis

7.2.7.1 Description

Electro-osmosis is a technique used to drain and stabilize slowly permeable soils during excavation. A direct current is passed through the soil, which draws the free water in the soil pores to the cathode (28). The water collects at the cathode and is pumped out. Steel well points serve as cathodes, and steel rods driven between wells are used as anodes. Common practice is to install the electrodes approximately 15 ft (4.6 m) apart, and apply a 30- to 180-volt potential. Current flow is 20 to 30 amps (28).

Recently, a similar technique has been applied to onsite wastewater disposal in soils with percolation rates slower than 60 min/in. (24 min/cm). A galvanic cell is constructed out of natural materials, which requires no external power source. This cell is capable of generating a

0.7- to 1.3-volt potential (29). Conventional absorption trenches are constructed and a mineral rock-filled anode is installed immediately adjacent to the trench. Coke-filled cathodes with graphite cores are installed some distance from the trench (see Figure 7-18). The water that moves to the cathode is claimed to be removed by evapotranspiration (30). These systems have been used successfully in California, Iowa, Minnesota, and Wyoming (29).

7.2.7.2 Site Considerations

Electro-osmosis systems were developed to enhance wastewater absorption in slowly permeable soils. They are used in soils with percolation rates slower than 60 min/in. (24 min/cm). Criteria for soil absorption trench or bed are presented in Table 7-1.

7.2.7.3 Design and Construction

The electro-osmosis system is patented. Design and construction of systems are done by licensees.

7.2.7.4 Operation and Maintenance

Once installed, no routine maintenance of the electrodes has been reported. Maintenance techniques for the soil absorption trench are presented in Section 7.2.2.5.

7.2.8 Effluent Distribution Network for Subsurface Soil Absorption Systems

Several different distribution networks are used in subsurface soil absorption systems. They include single line, closed loop, distribution box, relief line, drop box, and pressure networks. The objective of each is to apply the pretreated wastewater over the infiltrative surface.

The choice of one network over another depends on the type of system proposed and the method of wastewater application desired. Networks for the various types of systems versus the method of wastewater application are given in Table 7-12. Where more than one network is suitable, they are listed in order of preference.

FIGURE 7-18
 TYPICAL ELECTRO-OSMOSIS SYSTEM (30)

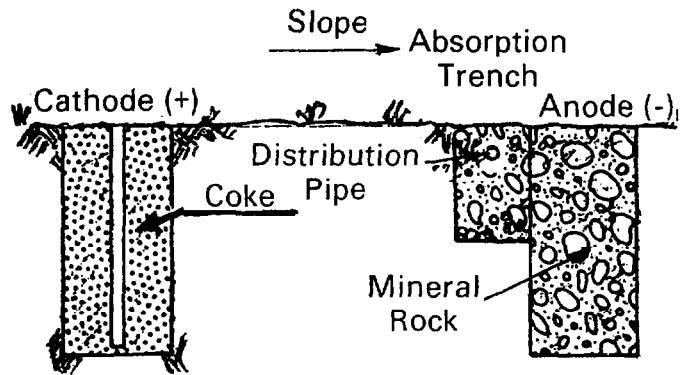
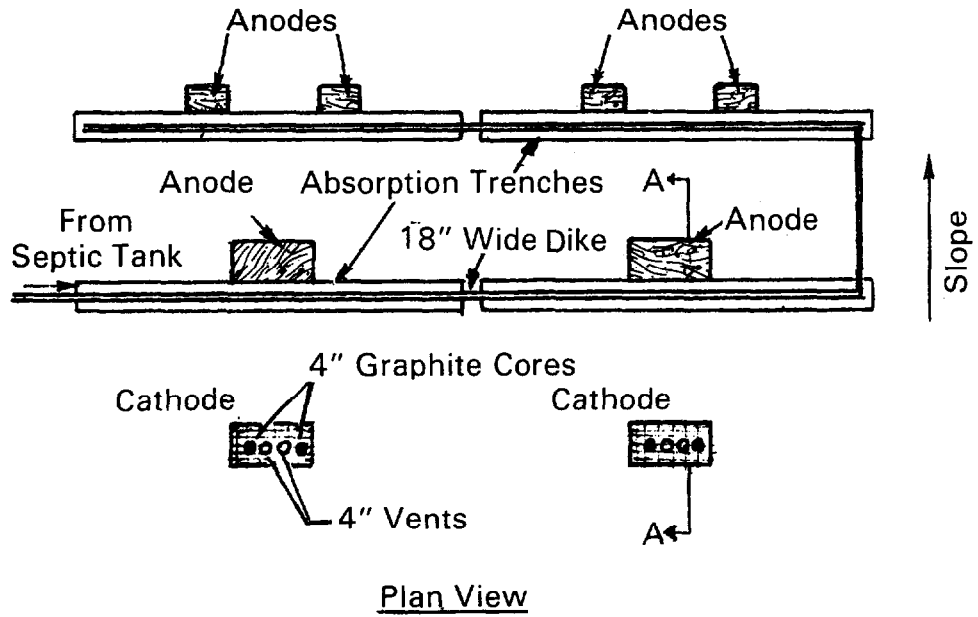

TABLE 7-12

DISTRIBUTION NETWORKS FOR VARIOUS SYSTEM DESIGNS AND APPLICATION METHODS^a

<u>Method of Application</u>	<u>Single Trench</u>	<u>Multi-Trench (Fills, Drains) On Level Site</u>	<u>Multi-Trench (Drains) On Sloping Site</u>	<u>Beds (Fills, Drains)</u>	<u>Mounds</u>
Gravity	Single line	Drop box Closed loop Distribution box	Drop box Relief line Distribution box ^b	Closed loop Distribution box	Not applicable
Dosing	Single line Pressure	Closed loop Pressure Distribution box	Distribution box	Closed loop Pressure Distribution box	Not applicable
Uniform Application	Pressure	Pressure	Pressure ^c	Pressure	Pressure

^a Distribution networks are listed in order of preference.

^b Use limited by degree of slope (see Section 7.2.8.1 d)

^c Because of the complexity of a pressure network on a sloping site, drop boxes or relief lines are suggested.

7.2.8.1 Design

a. Single Line

Single-line distribution networks are trenches loaded by gravity or dosing. The distribution line is a 3- to 4-in. (8- to 10-cm) diameter perforated pipe laid level in the center of the gravel-filled excavation (see Figure 7-19). The pipe is usually laid such that the holes are at or near the invert of the pipe. Where the length of single lines exceeds 100 ft (30 m), it is preferable to locate the wastewater inlet toward the center of the line.

b. Drop Box

Drop box networks are typically used for continuously ponded multi-trench systems on level to maximum sloping lots. It is a network that serially loads each trench to its full hydraulic capacity.

A drop box is a small, circular or square box with a removable cover. It has an inlet, one or two distribution lateral outlets, and an overflow. The lateral outlet inverts are located at or near the bottom of the box, all of the same diameter pipe. The overflow invert can be the same elevation as the crown of the lateral outlet, or up to 2 in. above it, to cause the full depth of the trench to flood. The inlet invert of the drop box may be at the same elevation as the overflow invert or a few inches above. An elevation difference of 1 to 2 in. (3 to 5 cm) between trenches is all that is needed to install a drop box network. The boxes may be buried, but it is suggested that the covers be left exposed for periodic inspection and maintenance (see Figure 7-20).

Drop boxes are installed at the wastewater inlet of each trench. The inlets may be located anywhere along the trench length. A solid wall pipe connects the overflow from the higher box to the inlet of the lower box. The first box in the network receives all the effluent from the pretreatment tank and distributes it into the first trench. When the first trench fills, the box overflows into the next trench. In this manner, each trench in the system is used successively to its full capacity. Thus, only the portion of the system required to absorb the wastewater is used. During periods of high flow or low absorptive capacity of the soil, more trenches will be used. When flows are low or during the hot dry summer months, the lower trenches may not be needed, so they may drain and dry out, automatically resting more trenches, which rejuvenates their infiltrative surfaces (11).

FIGURE 7-19
SINGLE LINE DISTRIBUTION NETWORK

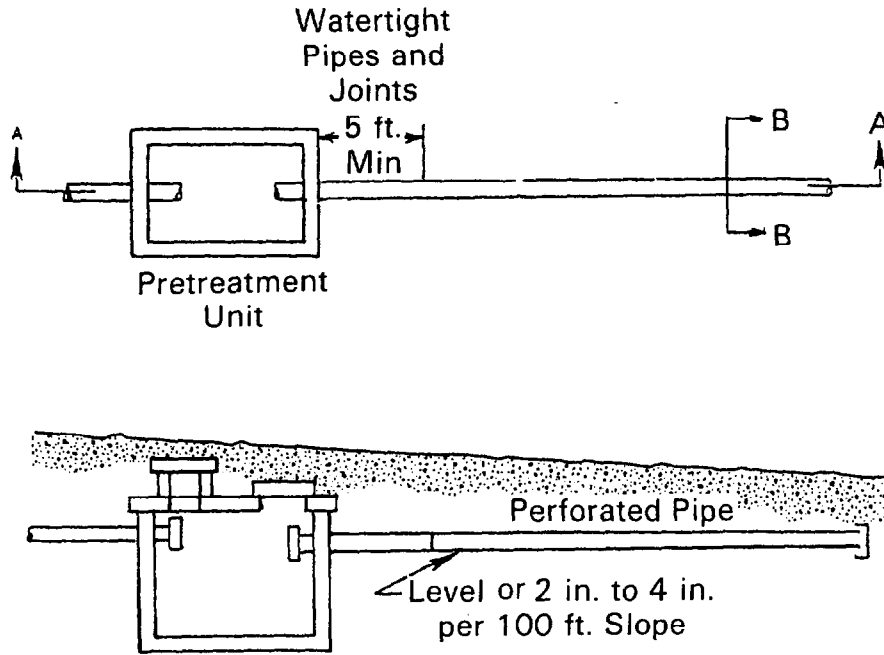

Section A-A

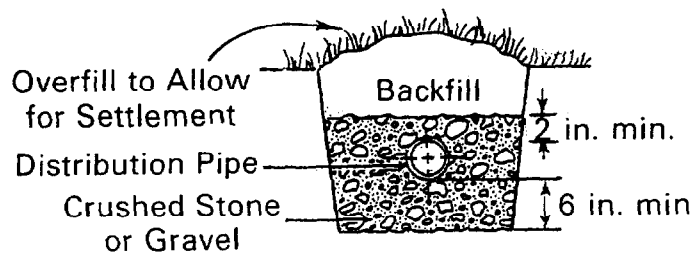

Section B-B

FIGURE 7-20

DROP BOX DISTRIBUTION NETWORK ([AFTER (22)])

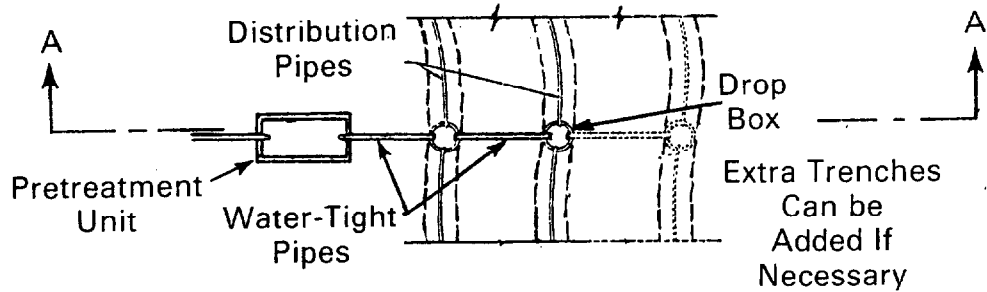
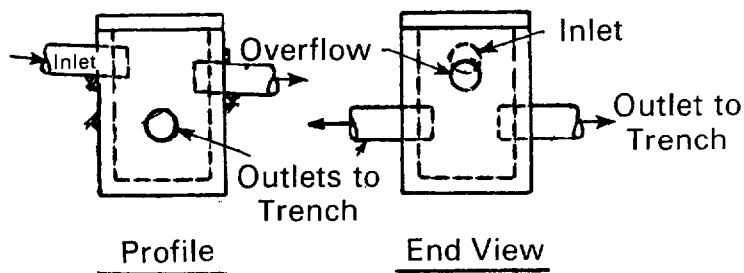
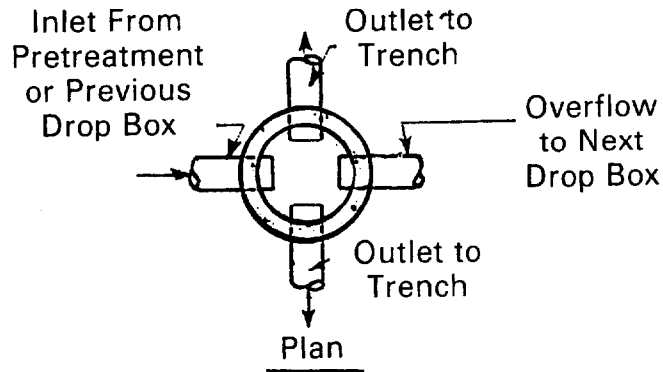

Plan

Covers May be Exposed at Surface if Insulated in Cold Climates

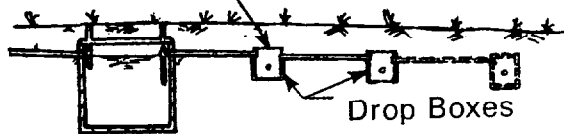

Section A-A

The liquid level in the trenches is established by the elevation of the overflow invert leading to the succeeding drop box. If the elevation of this invert is near the top of the rock in the trench, the entire trench sidewall will be utilized, maximum hydrostatic head will be developed to force the liquid into the surrounding soil, and evapotranspiration by plants during the growing season will be maximized by providing a supply of liquid to the overlying soil.

The drop box design has several advantages over single lines, closed loop, and distribution box networks for continuously ponded systems. It may be used on steeply sloping sites without surface seepage occurring unless the entire system is overloaded. If the system becomes overloaded, additional trenches can be added easily without abandoning or disturbing the existing system. Drop box networks also permit unneeded absorption trenches to rest and rejuvenate. The lower trenches are rested automatically when flows are low or infiltration capacity is high. The upper trenches may be rested when necessary by plugging the drop box lateral outlets.

c. Closed Loop

In absorption systems where the entire infiltrative surface is at one elevation, such as in beds or multi-trench systems on level or nearly level sites, closed loop networks may be used. The distribution pipe is laid level over the gravel filled excavation and the ends connected together with additional pipe with ell or tee fittings. In beds, the parallel lines are usually laid with 3 to 6 ft (0.9 to 1.8 m) spacings. A tee, cross, or distribution box may be used at the inlet to the closed system (See Figure 7-21).

d. Distribution Box

Distribution box networks may be used in multi-trench systems or beds with independent distribution laterals. They are suitable for all gravity-flow systems.

The distribution laterals in the network extend from a common watertight box called the distribution box. The box may be round or rectangular, with a single inlet, and an outlet for each distribution lateral. It has an exposed, removable cover. Its purpose is to divide the incoming wastewater equally between each lateral. To achieve this objective, the outlet inverts must be at exactly the same elevation. The inlet invert should be about 1 in. above the outlet inverts. Where dosing is employed or where the slope of the inlet pipe imparts a significant velocity to the wastewater flow, a baffle should be placed in front of the inlet to prevent short-circuiting.

FIGURE 7-21

CLOSED LOOP DISTRIBUTION NETWORK

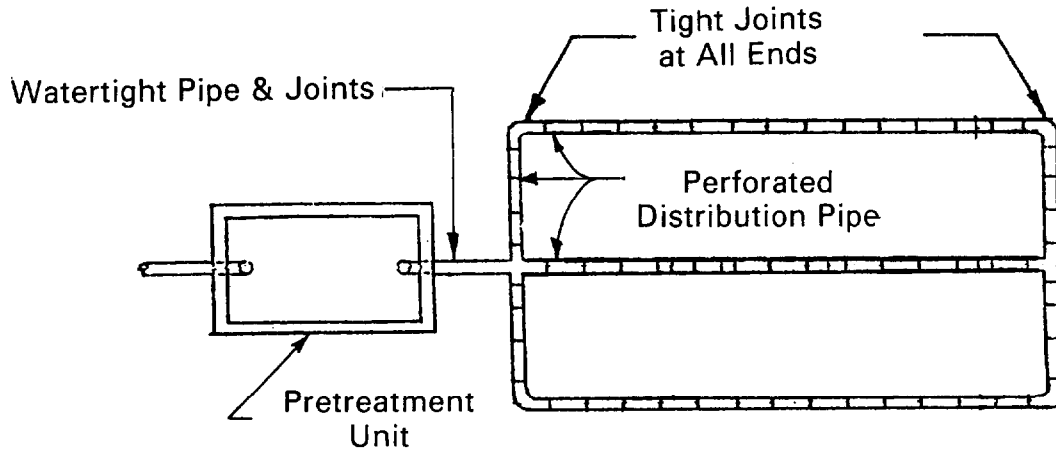

Distribution box networks are suggested only for absorption systems located on level or gently sloping sites, where the system can be installed so that the ground surface elevation above the lowest trench is above the box outlets (11). This is because it is difficult to prevent the distribution box from settling (11)(17)(31). If the box were to settle unevenly so that the lowest trench received a greater share of the effluent, wastewater would seep onto the ground surface unless the distribution lateral of the lowest trench were at a high enough elevation to back up the wastewater into the box, where it could flow into a different lateral. Therefore, to utilize the full capacity of each trench in the system, distribution box networks should be used only where each trench can back up into the distribution box (see Figure 7-22). On steeply sloping sites, other networks should be used, unless great care is used to construct the distribution box on a stable footing. If used for dividing flow between independent trenches, any combination of trenches can be rested by plugging the appropriate outlets.

e. Relief Line

Relief line networks may be used in place of drop box networks in continuously ponded multi-trench systems on sites up to the maximum permissible slopes. The network provides serial distribution as in drop

FIGURE 7-22

DISTRIBUTION BOX NETWORK

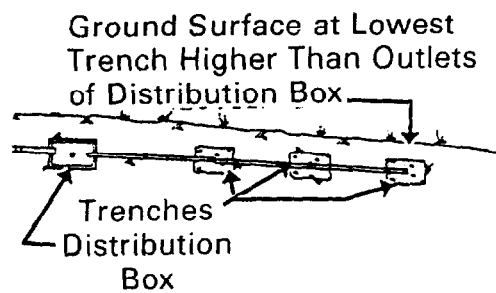
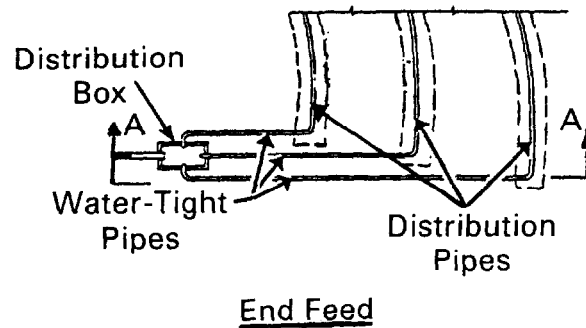
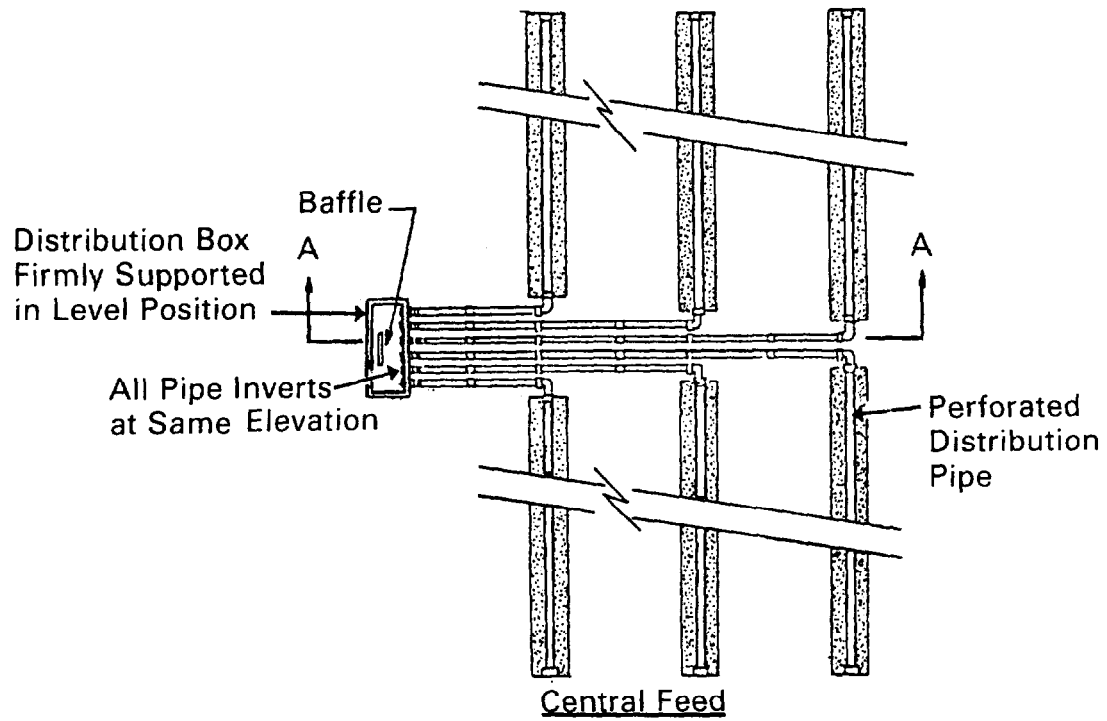

box networks (see Figure 7-23). However, the design makes it more difficult to add trenches to the system and it does not permit the owner to manually rest the upper trenches.

The network uses overflow or relief lines between trenches in place of drop boxes. The invert of the overflow section should be located near the top of the porous media to use the maximum capacity of the trench, but it should be lower than the septic tank outlet invert. The invert of the overflow from the first absorption trench should be at least 4 in. lower than the invert of the pretreatment unit outlet. Relief lines may be located anywhere along the length of the trench, but successive trenches should be separated 5 to 10 ft (1.3 to 3.0 m) to prevent short-circuiting.

f. Pressure Distribution

If uniform distribution of wastewater over the entire infiltrative surface is required, pressure distribution networks are suggested. These networks may also be used in systems that are dosed since the mode of the network operation is intermittent.

To achieve uniform distribution, the volume of water passing out each hole in the network during a dosing cycle must be nearly equal. To achieve this, the pressure in each segment of pipe must also be nearly equal. This is accomplished by balancing the head losses through proper sizing of the pipe diameter, hole diameter and hole spacing. Thus, approximately 75 to 85% of the total headloss incurred is across the hole in the lateral, while the remaining 15 to 25% is incurred in the network delivering the liquid to each hole. The networks usually consist of 1- to 3-in. (3- to 8-cm) diameter laterals, connected by a central or end manifold of larger diameter. The laterals are perforated at their inverts with 1/4 to 1/2 in. (0.6 to 1.3 cm) diameter holes. The spacing between holes is 2 to 10 ft (0.6 to 3.0 m) (see Figures 7-24 to 27).

Pumps are used to pressurize the network, although siphons may be used if the dosing chamber is located at a higher elevation than the lateral inverts. The active dosing volume is about 10 times the total lateral pipe volume. This ensures more uniform distribution since the laterals, drained after each dose, must fill before the network can become properly pressurized. (See Section 8.3 for dosing chamber design.)

FIGURE 7-23

RELIEF LINE DISTRIBUTION NETWORK

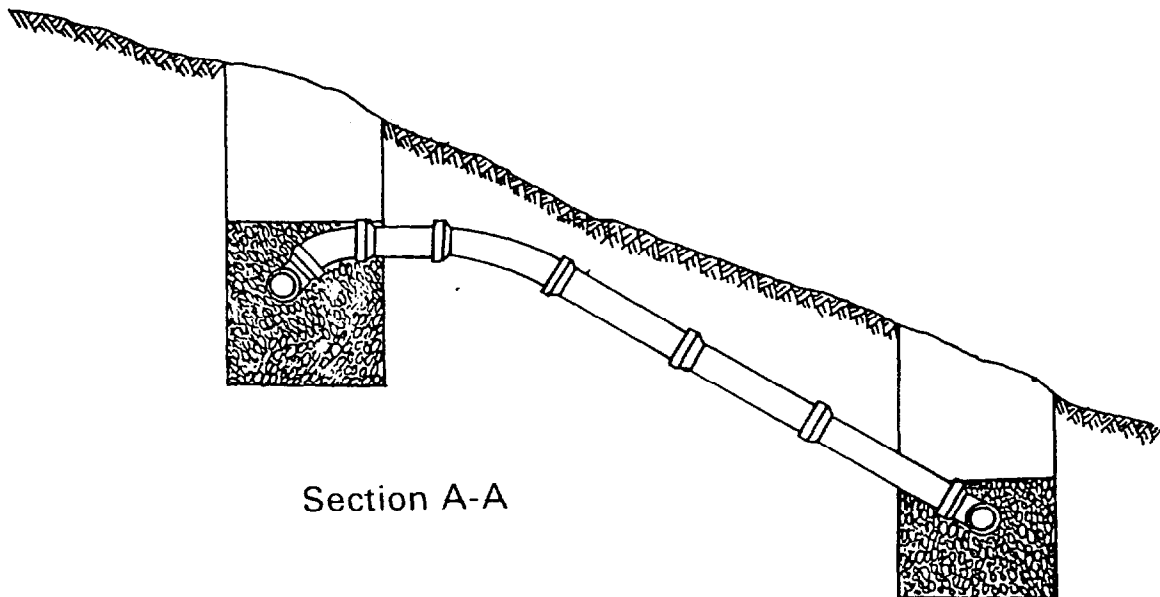
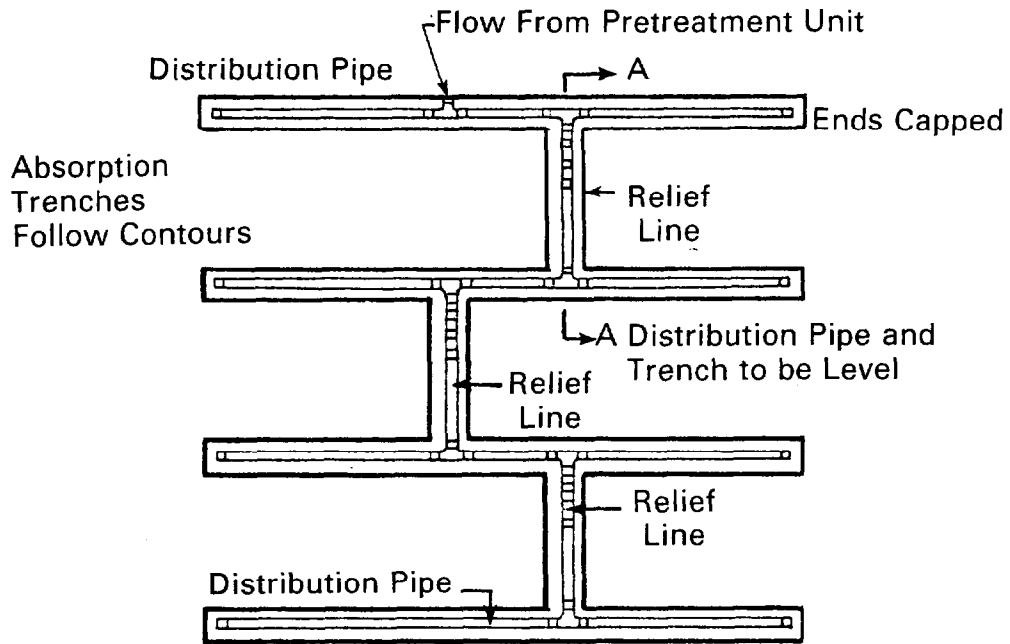

FIGURE 7-24
CENTRAL MANIFOLD DISTRIBUTION NETWORK

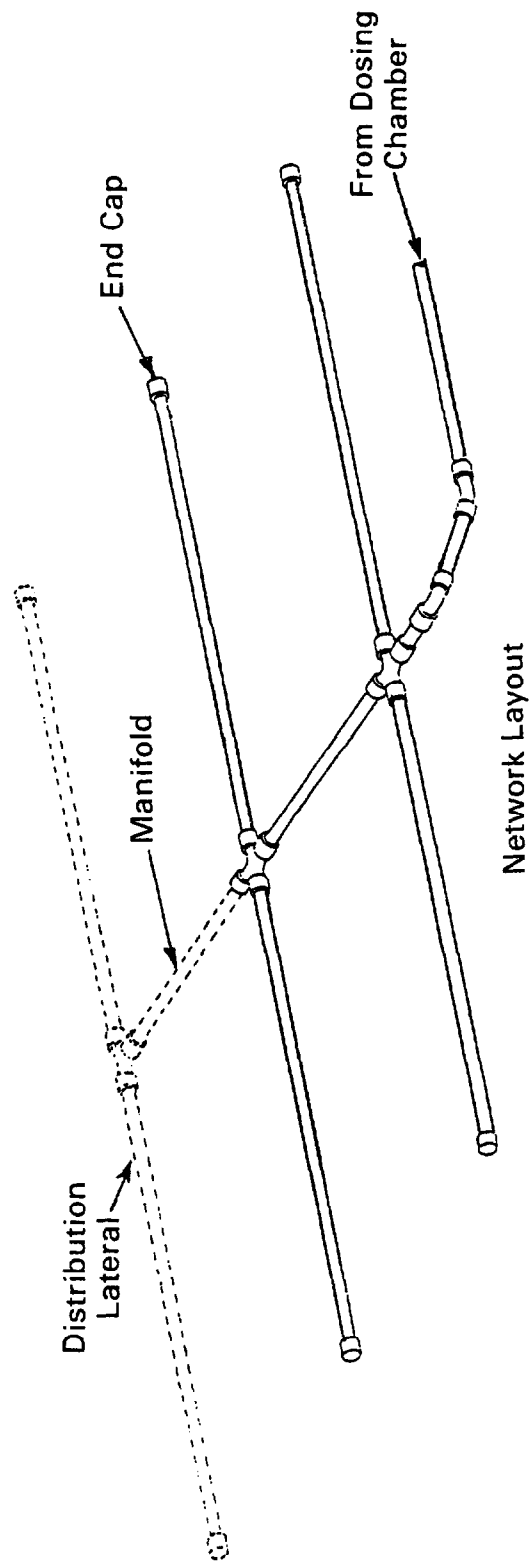

FIGURE 7-25
END MANIFOLD DISTRIBUTION NETWORK

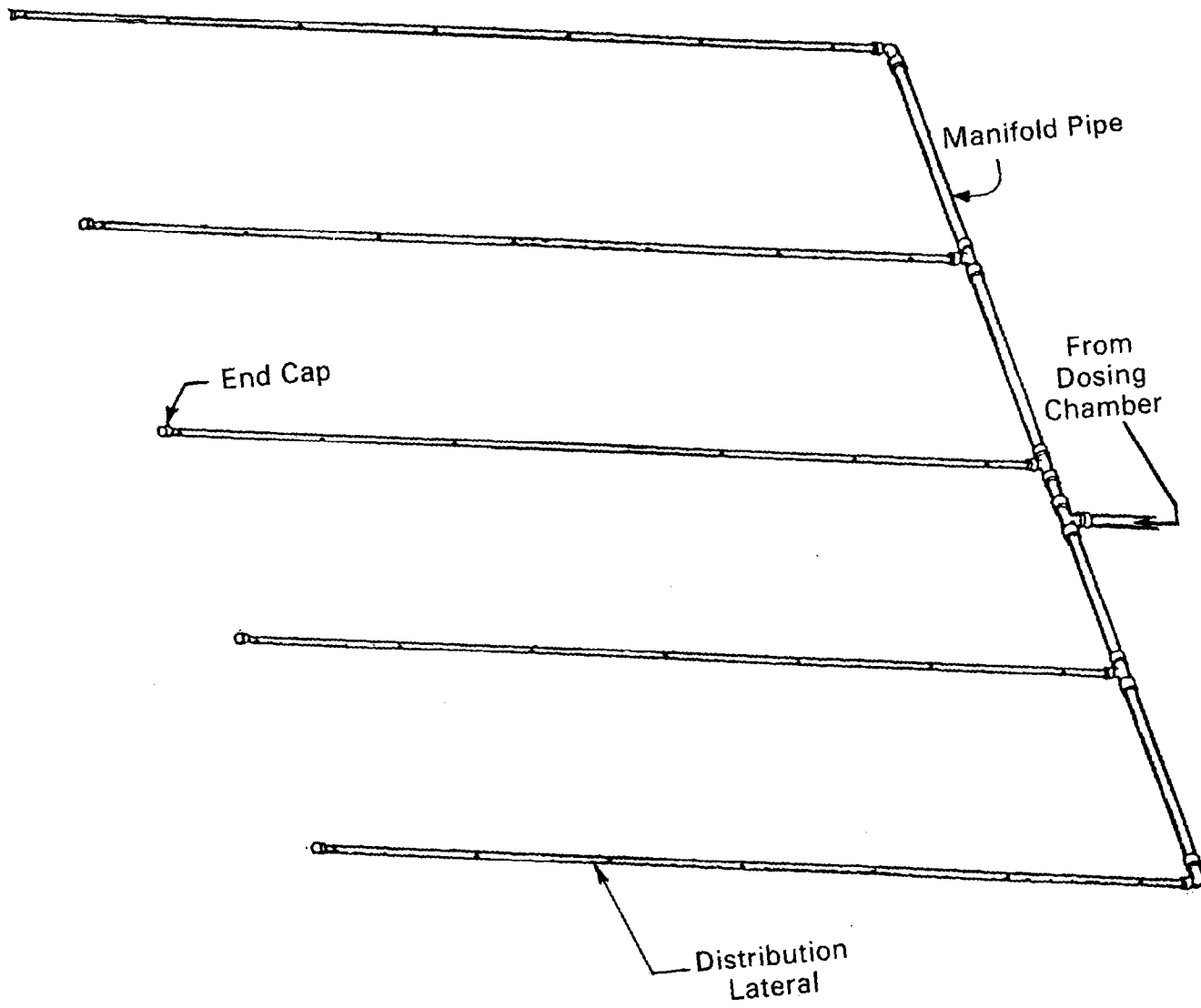
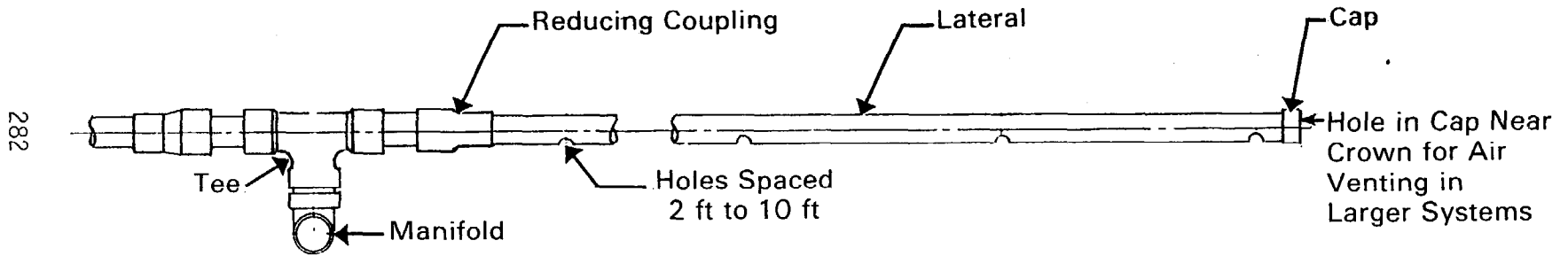

FIGURE 7-26

LATERAL DETAIL - TEE TO TEE CONSTRUCTION



282

FIGURE 7-27

LATERAL DETAIL - STAGGERED TEES OR CROSS CONSTRUCTION

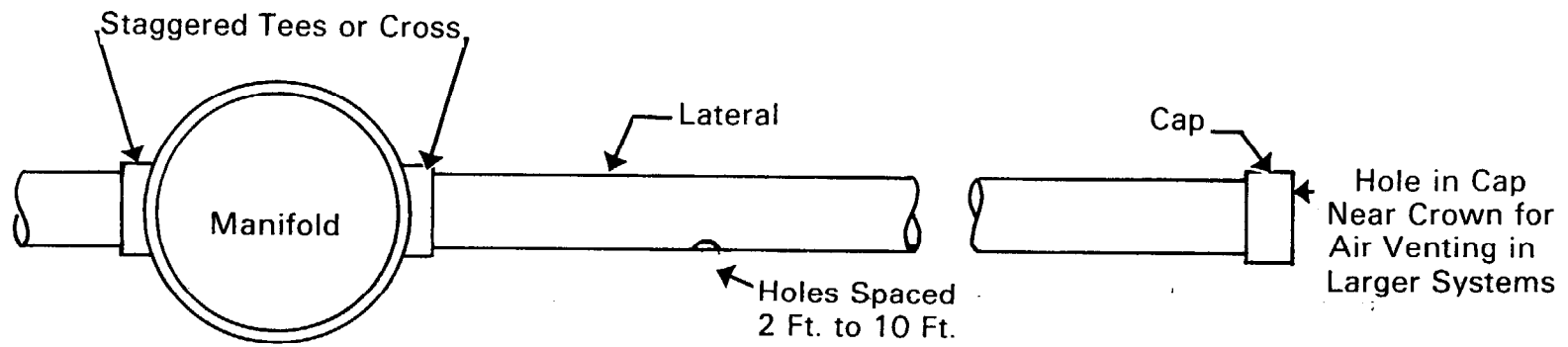

To simplify the design of small pressure distribution networks, Table 7-13, and Figures 7-28, 7-29, and 7-30, may be used. Examples 7-2 and 7-3 illustrate their use. Other design methods may be equally suitable, however.

TABLE 7-13
DISCHARGE RATES FOR VARIOUS SIZED HOLES
AT VARIOUS PRESSURES (gpm)

Pressure		Hole Diameter (in.)				
ft	psi	1/4	5/16	3/8	7/16	1/2
1	0.43	0.74	1.15	1.66	2.26	2.95
2	0.87	1.04	1.63	2.34	3.19	4.17
3	1.30	1.28	1.99	2.87	3.91	5.10
4	1.73	1.47	2.30	3.31	4.51	5.89
5	2.17	1.65	2.57	3.71	5.04	6.59

Example 7-2: Design of a Pressure Distribution Network for a Trench Absorption Field

Design a pressure network for an absorption field consisting of five trenches, each 3 ft wide by 40 ft long, and spaced 9 ft apart center to center.

- Step 1: Select lateral length. Two layouts are suitable for this system: central manifold (Figure 7-24) or end manifold (Figure 7-25). For a central manifold design, ten 20-ft laterals are used; for an end manifold design, five 40-ft laterals are required. The end manifold design is used in this example.
- Step 2: Select hole diameter and hole spacing for laterals. For this example, 1/4-in. diameter holes spaced every 30 in. are used, although other combinations could be used.

FIGURE 7-28

REQUIRED LATERAL PIPE DIAMETERS FOR VARIOUS HOLE DIAMETERS, HOLE SPACINGS, AND LATERAL LENGTHS^a
(FOR PLASTIC PIPE ONLY)

Lateral Length (ft)	LATERAL DIAMETER (IN)																																		
	Hole Diameter (in) 1/4							Hole Diameter (in) 5/16							Hole Diameter (in) 3/8							Hole Diameter (in) 7/16							Hole Diameter (in) 1/2						
	Hole Spacing (ft)							Hole Spacing (ft)							Hole Spacing (ft)							Hole Spacing (ft)							Hole Spacing (ft)						
	2	3	4	5	6	7	2	3	4	5	6	7	2	3	4	5	6	7	2	3	4	5	6	7	2	3	4	5	6	7					
10	1"							1"							1"							1"							1"						
15	1"							1"							1"							1"							1"						
20	1"							1"							1"							1 1/2"							1 1/4"						
25	1"							1 1/2"							1 1/4"							1 1/2"							1 1/2"						
30	1 1/2"							1 1/4"							1 1/2"							1 1/2"							1 1/2"						
35	1 1/2"							1 1/2"							1 1/2"							2"							2"						
40	2"							2"							2"							3"							3"						
45	2"							2"							2"							3"							3"						
50	2"							2"							2"							3"							3"						

^a Computed for plastic pipe only. The Hazen-Williams equation was used to compute headlosses through each pipe segment (Hazen-Williams C= 150). The orifice equation for sharp-edged orifices (discharge coefficient = 0.6) was used to compute the discharge rates through each orifice. The maximum lateral length for a given hole and spacing was defined as that length at which the difference between the rates of discharge from the distal end and the supply end orifice reached 10 percent of the distal end orifice discharge rate.

FIGURE 7-30

NOMOGRAPH FOR DETERMINING THE MINIMUM DOSE VOLUME FOR A GIVEN LATERAL DIAMETER, LATERAL LENGTH, AND NUMBER OF LATERALS

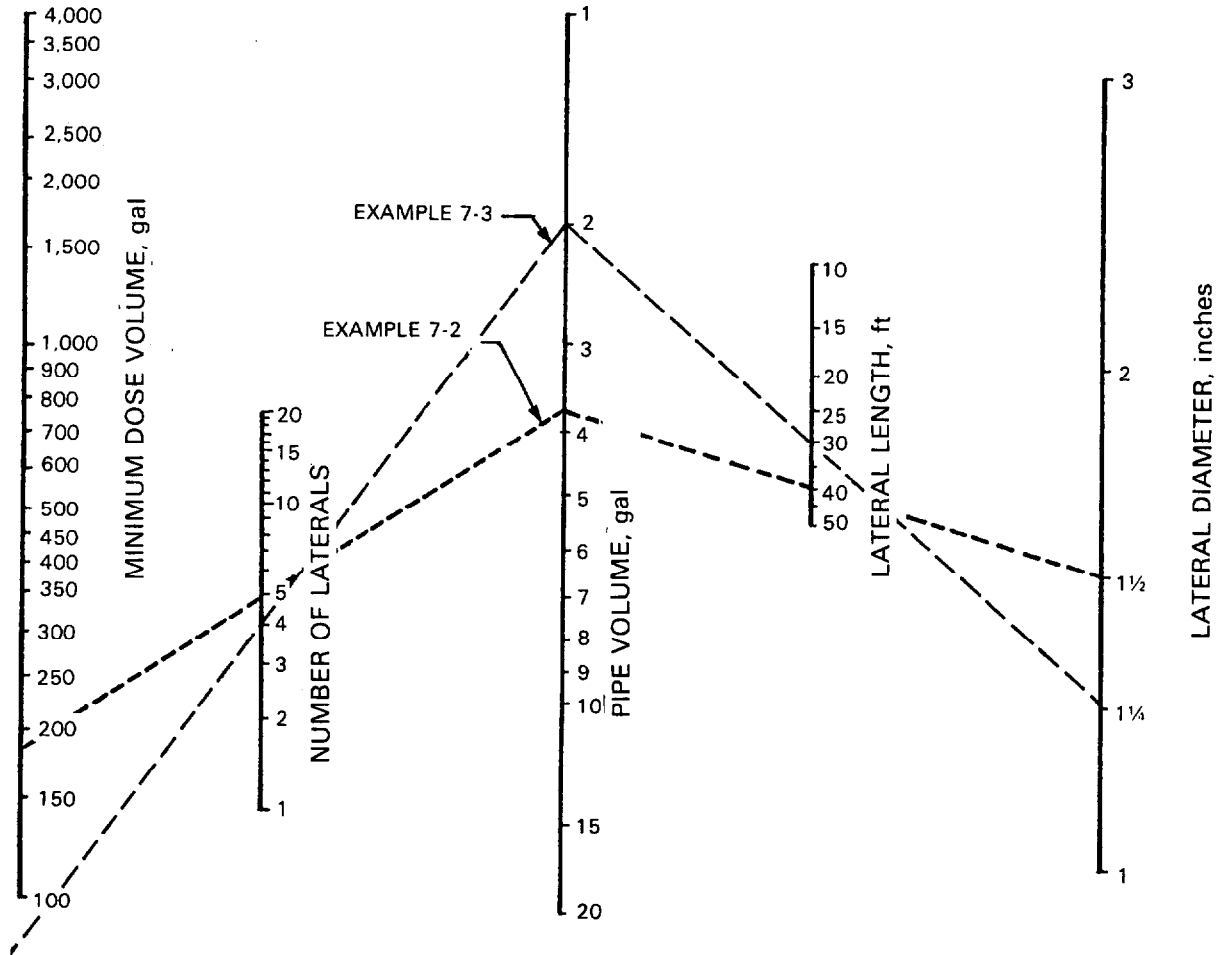

Step 3: Select lateral diameter. For 1/4-in. hole diameter, 30-in. hole spacing, and 40-ft length, Figure 7-28 indicates either a 1-1/4-in. or 1-1/2-in. diameter lateral could be used. The 1-1/2-in. diameter is selected for this example.

Step 4: Calculate lateral discharge rate. By maintaining higher pressures in the lateral, small variations in elevation along the length of the lateral and between laterals do not significantly affect the rates of discharge from each hole. This reduces construction costs, but increases pump size. For this example, a 2-ft head is to be maintained in the lateral. For a 1/4-in. hole at 2 ft of head, Table 7-13 shows the hole discharge rate to be 1.04 gpm.

$$\text{Number of holes/lateral} = \frac{40\text{-ft lateral length}}{2.5\text{-ft hole spacing}}$$

$$= 16$$

$$\text{Lateral discharge rate} = (16 \text{ holes/lateral}) \times (1.04 \text{ gpm/hole})$$

$$= 16.6 \text{ gpm/lateral}$$

Step 5: Select manifold size. There are to be five laterals spaced 9 ft apart. A manifold length of 36 ft is therefore required.

For five laterals and 16.6 gpm/lateral, Figure 7-29 indicates that a 3-in. diameter manifold is required.

Step 6: Determine minimum dose volume (Figure 7-30).

With: lateral diameter = 1-1/2 in.

lateral length = 40 ft

number of laterals = 5

Then: pipe volume = 3.7 gal

Minimum dose volume = approx. 200 gal

The final dose volume may be larger than this minimum depending on the desired number of doses per day (see Table 7-4).

See Figure 7-31 for completed network design.

Step 7: Determine minimum discharge rate.

$$\text{Minimum discharge rate} = (5 \text{ laterals}) \times (16.6 \text{ gpm/lateral})$$

$$= 83 \text{ gpm}$$

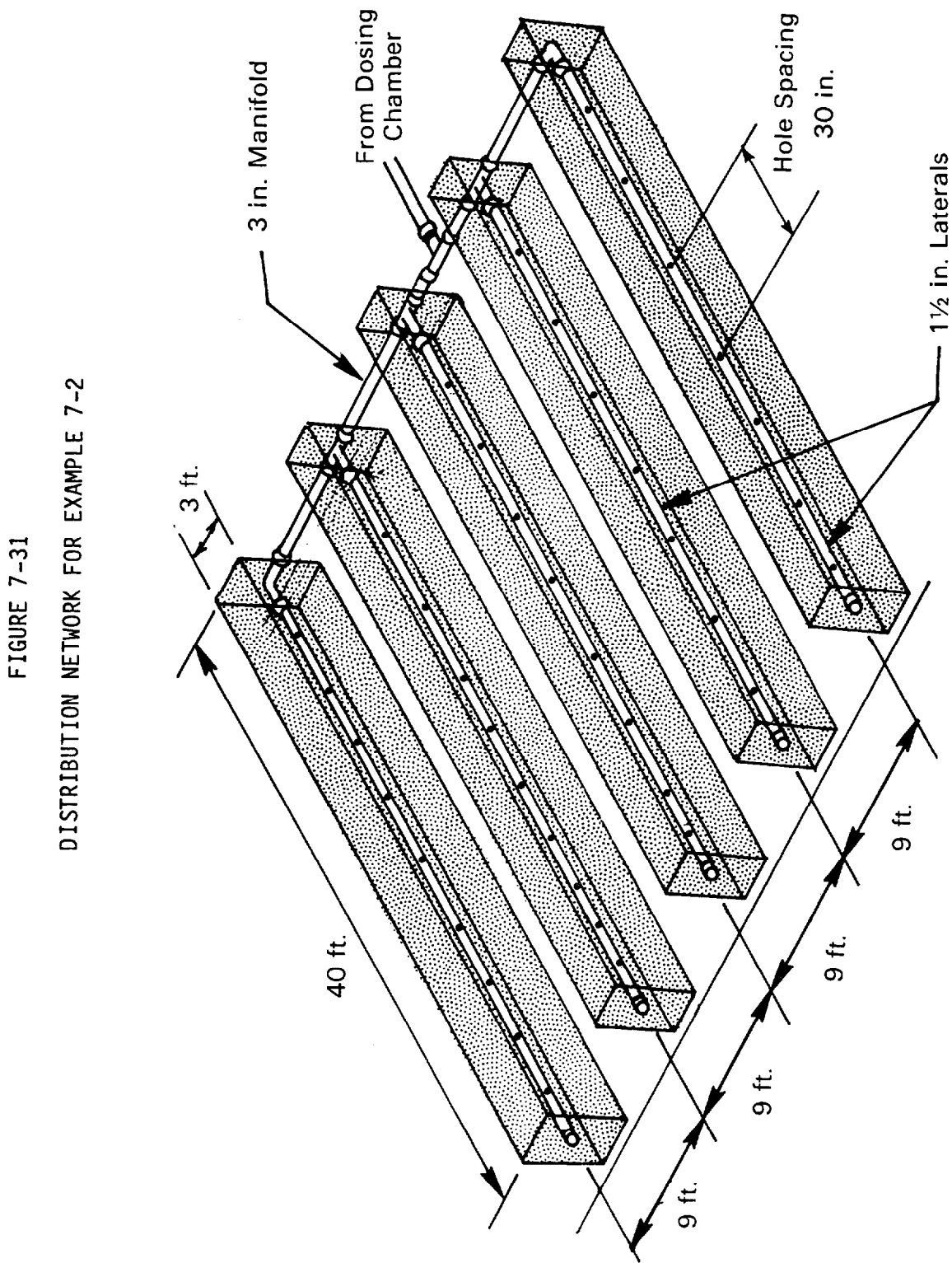

FIGURE 7-31
 DISTRIBUTION NETWORK FOR EXAMPLE 7-2

Step 8: Select proper pump or siphon.

For a pump system, the total pumping head of the network must be calculated. This is equal to the elevation difference between the pump and the distribution lateral inverts, plus friction loss in the pipe that delivers the wastewater from the pump to the network at the required rate, plus the desired pressure to be maintained in the network (the velocity head is neglected). A pump is then selected that is able to discharge the minimum rate (83 gpm) at the calculated pumping head.

For a siphon system, the siphon discharge pipe must be elevated above the lateral inverts at a distance equal to the friction losses and velocity head in the pipe that delivers the wastewater from the siphon to the network at the required rate, plus the desired pressure to be maintained in the network.

For this example, assume the dosing tank is located 25 ft from the network inlet, and the difference in elevation between the pump and the inverts of the distribution laterals is 5 ft.

a. Pump (assume 3-in. diameter delivery pipe)

1. Friction loss in 3-in. pipe at 83 gpm (from Table 7-14)

$$= 1.38 + \frac{3}{10} (1.73 - 1.38)$$
$$= 1.49 \text{ ft}/100 \text{ ft}$$

Friction loss in 25 ft

$$= (1.49 \text{ ft}/100 \text{ ft}) \times (25 \text{ ft})$$
$$= 0.4 \text{ ft}$$

2. Elevation Head = 5.0 ft

3. Pressure to be maintained = 2.0

Total pumping head = 7.4 ft

Therefore, a pump capable of delivering at least 83 gpm against 7.4 ft of head is required.

b. Siphon (assume 4-in. diameter delivery pipe)

1. Friction loss in 4-in. pipe at 83 gpm (from Table 7-14)

$$= 0.37 + \frac{3}{10} (0.46 - 0.37)$$
$$= 0.4 \text{ ft}/100 \text{ ft}$$

TABLE 7-14

FRICITION LOSS IN SCHEDULE 40 PLASTIC PIPE, C = 150
(ft/100 ft)

Flow gpm	Pipe Diameter (in.)								
	1	1-1/4	1-1/2	2	3	4	6	8	10
1	0.07								
2	0.28	0.07							
3	0.60	0.16	0.07						
4	1.01	0.25	0.12						
5	1.52	0.39	0.18						
6	2.14	0.55	0.25	0.07					
7	2.89	0.76	0.36	0.10					
8	3.63	0.97	0.46	0.14					
9	4.57	1.21	0.58	0.17					
10	5.50	1.46	0.70	0.21					
11		1.77	0.84	0.25					
12		2.09	1.01	0.30					
13		2.42	1.17	0.35					
14		2.74	1.33	0.39					
15		3.06	1.45	0.44	0.07				
16		3.49	1.65	0.50	0.08				
17		3.93	1.86	0.56	0.09				
18		4.37	2.07	0.62	0.10				
19		4.81	2.28	0.68	0.11				
20		5.23	2.46	0.74	0.12				
25			3.75	1.10	0.16				
30			5.22	1.54	0.23				
35				2.05	0.30	0.07			
40				2.62	0.39	0.09			
45				3.27	0.48	0.12			
50				3.98	0.58	0.16			
60					0.81	0.21			
70					1.08	0.28			
80					1.38	0.37			
90					1.73	0.46			
100					2.09	0.55	0.07		
150						1.17	0.16		
200							0.28	0.07	
250							0.41	0.11	
300							0.58	0.16	
350							0.78	0.20	0.07
400							0.99	0.26	0.09
450							1.22	0.32	0.11
500								0.38	0.14
600								0.54	0.18
700								0.72	0.24
800									0.32
900									0.38
1000									0.46

Friction loss in 25 ft

$$\begin{aligned} &= (0.4 \text{ ft}/100 \text{ ft}) \times (25 \text{ ft}) \\ &= 0.10 \text{ ft} \end{aligned}$$

2. Velocity head in delivery pipe

$$\text{Discharge rate} = 83 \text{ gpm} = 0.185 \text{ ft}^3/\text{sec}$$

$$\text{Area} = (1/4)\pi \left(\frac{4}{12}\right)^2 = 0.087 \text{ ft}^2$$

$$\text{Velocity} = \frac{0.185 \text{ ft}^3/\text{sec}}{0.087 \text{ ft}^2} = 2.13 \text{ ft}/\text{sec}$$

$$\begin{aligned} \text{Velocity head} &= \frac{(\text{Velocity})^2}{2g} \\ &= \frac{([2.13] \text{ ft}/\text{sec})^2}{2(32.2 \text{ ft}/\text{sec}^2)} \\ &= 0.07 \text{ ft} \end{aligned}$$

3. Pressure to be maintained

$$= \underline{2.0 \text{ ft}}$$

$$\text{Total} \quad \quad \quad 2.2 \text{ ft}$$

Minimum elevation of the siphon discharge invert above the lateral inverts must be 2.2 ft.

In summary, the final network design consists of five 40-ft laterals 1-1/2 in. in diameter connected with a 36-ft end manifold 3-in. in diameter, with the inlet from the dosing chamber at one end of the manifold. The inverts of the laterals are perforated with 1/4-in. holes spaced every 30 in.

Example 7-3: Design of a Pressure Distribution Network for a Mound

Design a pressure distribution network for the mound designed in Example 7-1.

Step 1: Select lateral length. A central manifold (Figure 7-24) design is used in this example.

$$\begin{aligned}\text{Lateral length} &= \frac{65 \text{ ft}}{2} - 0.5 \text{ ft (for manifold)} \\ &= 32 \text{ ft}\end{aligned}$$

Step 2: Select hole diameter and hole spacing for laterals. For this example, 1/4-in. diameter holes spaced every 30 in. are used, although other combinations could be used.

Step 3: Select lateral diameter. For 1/4-in. hole diameter, 30-in. hole spacing, and 32-ft lateral length, Figure 7-28 indicates that either a 1-1/4-in. or 1-1/2-in. diameter lateral could be used. The 1-1/4-in. diameter is selected for this example.

Step 4: Calculate lateral discharge rate. A 2-ft head is to be maintained in the lateral.

For 1/4-in. hole at 2 ft of head, Table 7-13 shows the hole discharge rate to be 1.04 gpm.

$$\begin{aligned}\text{Number of holes per lateral} &= \frac{32\text{-ft lateral length}}{2.5\text{-ft hole spacing}} \\ &= 13\end{aligned}$$

$$\text{Lateral discharge rate} = (13 \text{ holes/lateral}) \times (1.04 \text{ gpm/hole})$$

$$= 13.5 \text{ gpm/lateral}$$

Step 5: Select manifold size. There are to be four laterals (two on either side of the center manifold) spaced 3 ft apart. A manifold length of less than 5 ft is required (see Figure 7-32).

For four laterals, 13.5 gpm/lateral, and manifold length less than 5 ft, Figure 7-29 indicates that a 1-1/2-in. diameter manifold is required.

FIGURE 7-32
DISTRIBUTION NETWORK FOR EXAMPLE 7-3

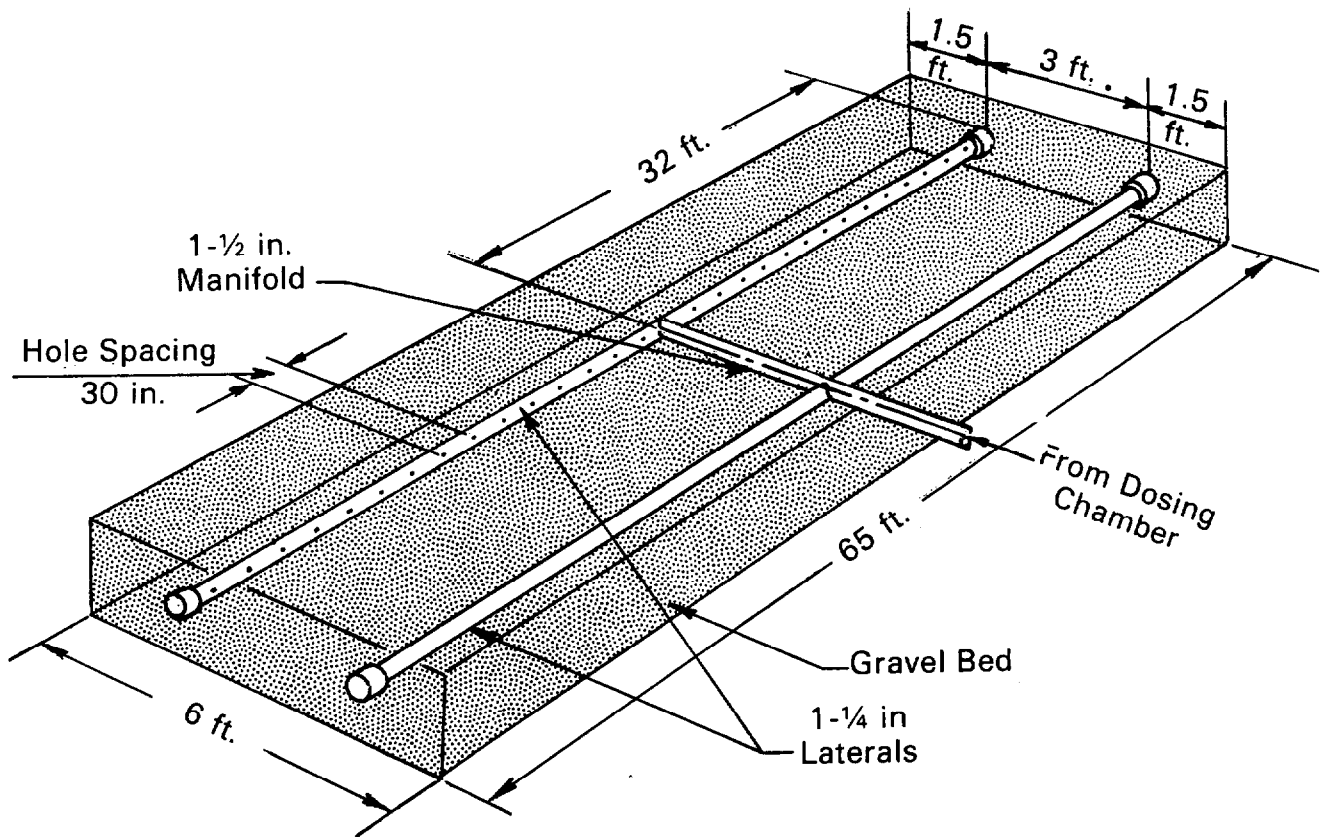

Step 6: Determine minimum dose volume (Figure 7-30).

With: lateral diameter = 1-1/4 in.
lateral length = 32 ft
number of laterals = 4

Then: pipe volume = 2 gal
Minimum dose volume = <100 gal

From Table 7-4, for a medium texture sand, 4 doses/day are desirable. Therefore, the dose volume is:

$$\frac{450 \text{ gpd}}{4} = 112 \text{ gal/dose}$$

Step 7: Determine minimum discharge rate.

Minimum discharge rate = (4 laterals) x (13.5 gpm/lateral)
= 54 gpm

Step 8: Select proper pump. For this example, assume the dosing tank is located 75 ft from the network inlet, the difference in elevation between the pump and the inverts of the distribution laterals is 7 ft, and a 3-in. diameter delivery pipe is to be used.

Friction loss in 3-in. pipe at 54 gpm (from Table 7-14)

$$= 0.58 + \frac{4}{10} (0.81 - 0.58)$$

$$= 0.67 \text{ ft/100 ft}$$

Friction loss in 75 ft

$$= (0.67 \text{ ft/100 ft}) \times (75 \text{ ft})$$

$$= 0.5 \text{ ft}$$

Elevation head = 7.0 ft

Pressure to be maintained = 2.0 ft

Total pumping head = 9.5 ft

Therefore, a pump capable of delivering at least 54 gpm against 9.5 ft of head is required.

In summary, the final network design consists of four 32-ft laterals 1-1/4 in. in diameter (two on each side of a 3-in. diameter center manifold). The inverts of the laterals are perforated with 1/4-in. holes spaced every 30 in.

g. Other Distribution Networks

Several other distribution network designs are occasionally used. Among these are the inverted network and leaching chambers. While users of these networks claim they are superior to conventional networks, comprehensive evaluations of their performance have not been made.

Inverted Network: This network uses perforated pipe with the holes located in the crown rather than near the invert (32). This arrangement is designed to provide more uniform distribution of wastewater over a large area, and to prolong the life of the field by collecting any settleable solids passing out of the septic tank in the bottom of the pipe. Water-tight sumps are located at both ends of each inverted line to facilitate periodic removal of the accumulated solids.

Leaching Chambers: In place of perforated pipe and gravel for distribution and storage of the wastewater, this method employs open bottom chambers. The chambers interlock to form an underground cavern over the soils' infiltrative surface. The wastewater is discharged into the cavern through a central weir, trough, or splash plate and allowed to flow over the infiltrative surface in any direction. Access holes in the roof of the chamber allow visual inspection of the soil surface and maintenance as necessary. A large number of these systems have been installed in the northeastern United States (see Figure 7-33).

7.2.8.2 Materials

Three to 4-in. (8- to 10-cm) diameter pipe or tile is typically used for nonpressurized networks. Either perforated pipe or 1-ft (30 cm) lengths of suitable drain tile may be used. The perforated pipe commonly has one or more rows of 3/8- to 3/4-in. (1.0- to 2.0-cm) diameter holes. Hole spacing is not critical. Table 7-15 can be used as a guide for acceptable materials for nonpressurized networks.

Plastic pipe is used for pressure distribution networks because of the ease of drilling and assembly. Either PVC Schedule 40 (ASTM D 2665) or ABS (ASTM 2661) pipe may be used.

TABLE 7-15
PIPE MATERIALS FOR NONPRESSURIZED DISTRIBUTION NETWORKS

<u>Type of Material</u>	<u>Specification</u>	<u>Class</u>
Clay Drain Tile	ASTM C-4	Standard Drain Tile
Clay Pipe Standard and Extra- Strength Perforated	ASTM C-211	Standard
Bituminized Fiber Pipe Homogeneous Perforated	ASTM D-2312	
Laminated-Wall Perforated	ASTM D-2313	
Concrete Pipe Perforated Concrete	ASTM C-44 (Type 1 or Type 2)	ASTM C-14 ^a
Plastic Acrylonitrile- Butadiene- Styrene (ABS)	ASTM D-2751 ^b	
Polyvinyl Chloride (PVC)	ASTM D-2729 ^b D-3033 ^b D-3034 ^b	
Styrene-Rubber Plastic (SR)	ASTM D-2852 ^b D-3298 ^b	
Polyethylene (PE) o Straight Wall o Corrugated (Flexible)	ASTM D-1248 ^b ASTM F-405-76 ^b	

^a Must be of quality to withstand sulfuric acid.

^b These specifications are material specifications only. They do not give the location or shape of perforations.

FIGURE 7-33
SCHEMATIC OF A LEACHING CHAMBER

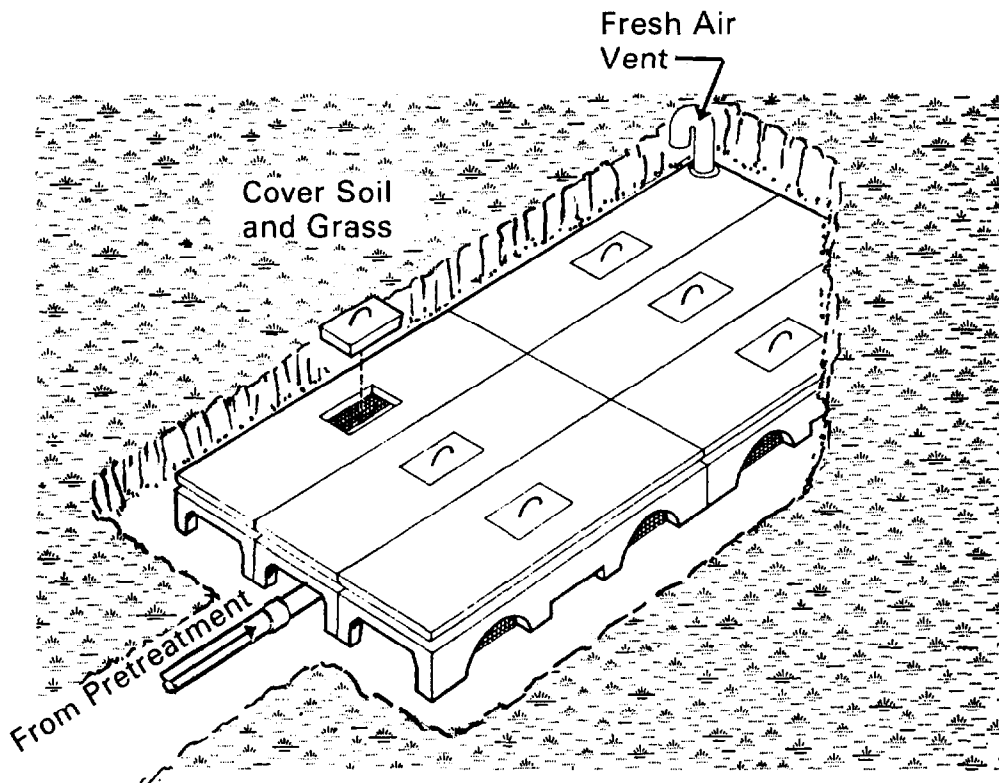

7.2.8.3 Construction

a. Gravity Network Pipe Placement

To insure a free flow of wastewater, the distribution pipe should be laid level or on a grade of 1 in. to 2 in. per 100 ft (8.5 to 16.9 cm/100 m). To maintain a level or uniform slope, several construction techniques can be employed. In each case a tripod level or transit is used to obtain the proper grade elevations. Hand levels are not adequate.

The rock is placed in the excavation to the elevation of the pipe invert. The rock must be leveled by hand to establish the proper grade. Once the pipe is laid, more rock is carefully placed over the top of the pipe. Care must also be taken when flexible corrugated plastic pipe is used, because the pipe tends to "float" up as rock is placed over the top of the pipe. One method is to employ special holders which can be removed once all the rock is in place (see Figure 7-34).

FIGURE 7-34

USE OF METAL HOLDERS FOR THE LAYING OF FLEXIBLE PLASTIC PIPE

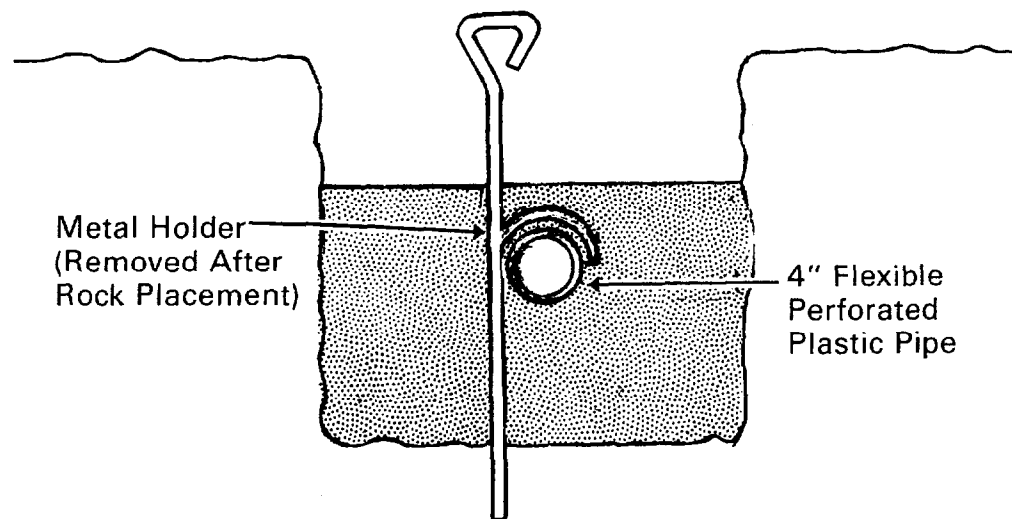

b. Pressure Network Pipe Placement

Pressure distribution networks are usually fabricated at the construction site. This may include drilling holes in distribution laterals. The holes must be drilled on a straight line along the length of the pipe. This can be accomplished best by using 1-in. by 1-in. angle iron as a straight-edge to mark the pipe. The holes are then drilled at the proper spacing. Care must be used to drill the holes perpendicular to the pipe and not at an angle. All burrs left around the holes inside the pipe should be removed. This can be done by sliding a smaller diameter pipe or rod down the pipe to knock the burrs off.

Solvent weld joints are used to assemble the network. The laterals are attached to the manifold such that the perforations lie at the bottom of the pipe.

Since the network is pressurized, small elevation differences along the length of the lateral do not affect the uniform distribution significantly. However, these variations should be held within 2 to 3 in. (5 to 8 cm). The rock is placed in the absorption area first, to the elevation of the distribution laterals. The rock should be leveled by hand, maintaining the same elevation throughout the system, before laying the pipe. After the pipe is laid, additional rock is placed over the pipe.

c. Distribution Boxes

If used, distribution boxes should be installed level and placed in an area where the soil is stable and remains reasonably dry. To protect the box from frost heaving, a 6-in. (15-cm) layer of 1/2- to 2-1/2-in. (1.2- to 6.4-cm) rock should be placed below and around the sides of the box. Solid wall pipe should be used to connect the box with the distribution laterals. Separate connections should be made for each lateral. To insure a more equal division of flow, the slope of each connecting pipe should be identical for at least 5 to 10 ft (1.3 to 3.0 m) beyond the box.

7.3 Evaporation Systems

7.3.1 Introduction

Two basic types of onsite evaporation systems are in use today:

1. Evapotranspiration beds (with and without infiltration)
2. Lagoons (with and without infiltration)

The advantages of these systems are that they utilize the natural energy of the sun and, optionally, the natural purification capabilities of soil to dispose of the wastewater. They must, however, be located in favorable climates. In some water-short areas where consumptive water use is forbidden (e.g., Colorado), they may not be allowed.

Mechanical evaporators are in the experimental stage, and are not commercially available. For this reason, they are not included in this discussion.

7.3.2 Evapotranspiration and Evapotranspiration/Absorption Beds

7.3.2.1 Introduction

Evapotranspiration (ET) beds can be used to dispose of wastewater to the atmosphere so that no discharge to surface or groundwater is required. Evapotranspiration/absorption (ETA) is a modification of the ET concept in which discharges to both the atmosphere and to the groundwater are incorporated. Both ET and ETA have been utilized for onsite wastewater disposal to the extent that several thousand of these systems are in use in the United States (33).

7.3.2.2 Description

Onsite ET disposal normally consists of a sand bed with an impermeable liner and wastewater distribution piping (see Figure 7-35). The surface of the sand bed may be planted with vegetation. Wastewater entering the bed is normally pretreated to remove settleable and floatable solids. An ET bed functions by raising the wastewater to the upper portion of the bed by capillary action in the sand, and then evaporating it to the atmosphere. In addition, vegetation transports water from the root zone to the leaves, where it is transpired. In ETA systems, the impervious liner is omitted, and a portion of the wastewater is disposed of by seepage into the soil.

Various theoretical approaches are used to describe the evaporation process. This suggests that there may be some uncertainty associated with a precise quantitative description of the process. However, current practice is to limit the uncertainties by basing designs on a correlation between available pan evaporation data and observed ET rates, thereby minimizing assumptions and eliminating the need to average long-term climatic data. References (33)(34)(35) and (36) provide a more detailed discussion of the correlation method.

7.3.2.3 Application

Onsite systems utilizing ET disposal are primarily used where geological limitations prevent the use of subsurface disposal, and where discharge to surface waters is not permitted or feasible. The geological conditions that tend to favor the use of ET systems include very shallow soil mantle, high groundwater, relatively impermeable soils, or fractured bedrock. ETA systems are generally used where slowly permeable soils are encountered.

FIGURE 7-35

CROSS SECTION OF TYPICAL ET BED

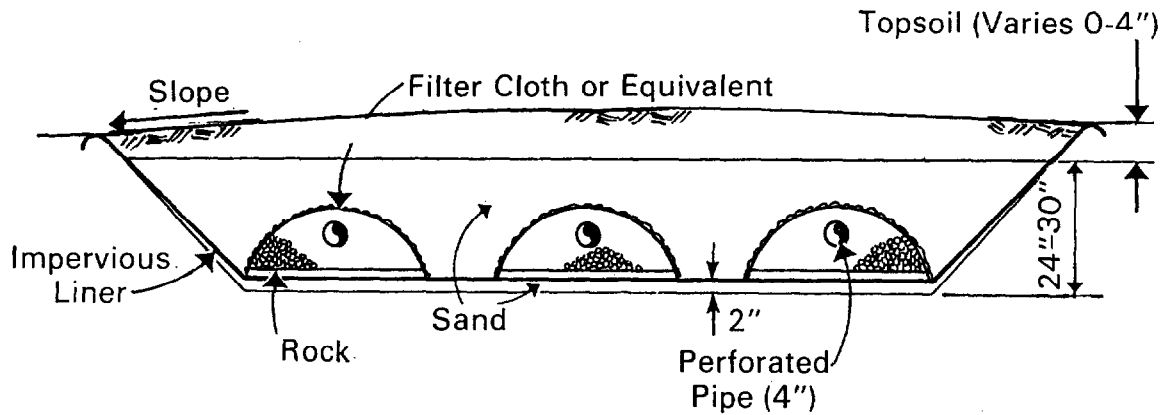

Although ET systems may be used where the application of subsurface disposal systems is limited, they are not without limitations. As with other disposal methods that require area-intensive construction, the use of ET systems can be constrained by limited land availability and site topography. Based on experience to date with ET disposal for year-round single-family homes, approximately 4,000 to 6,000 ft² (370 to 560 m²) of available land is typically required. The maximum slope at which an ET system is applicable has not been established, but use on slopes greater than 15% may be possible if terracing, serial distribution, and other appropriate design features are incorporated.

By far the most significant constraint on the use of ET systems is climatic conditions. The evaporation rate is controlled primarily by climatic factors such as precipitation, wind speed, humidity, solar radiation, and temperature. Recent studies indicate that essentially all of the precipitation that falls on an ET bed infiltrates into the bed and becomes part of the hydraulic load that requires evaporation (33)(34) (37). Provisions for long-term storage of effluent and precipitation in ET systems during periods of negative net evaporation, and for subsequent evaporation during periods of positive net evaporation, are expensive. Thus, the year-around use of nondischarging ET systems appears to be feasible only in the arid and semiarid portions of the western and southwestern United States where evaporation exceeds precipitation during every month of operation, so that long-term storage capacity is not

required. ET systems for summer homes may be feasible in the more temperate parts of the country. For ETA systems, the range of applicability is less well defined, but the soils must be capable of accepting all of the influent wastewater if net evaporation is zero for any significant periods of the year.

In addition to climate and site conditions, the characteristics of wastewater discharged to an onsite disposal system may affect its application. For ET disposal, pretreatment to remove settleable and floatable solids is necessary to prevent physical clogging of the wastewater distribution piping. The relative advantages of aerobic versus septic tank pretreatment for ET and ETA systems have been discussed in the literature (33)(35)(37)(38). Although each method has been supported by some researchers, reports of well-documented, controlled studies indicate that septic tank pretreatment is adequate (33)(34)(37).

7.3.2.4 Factors Affecting Performance

The following factors affect the performance of ET and ETA systems:

1. Climate
2. Hydraulic loading
3. Sand capillary rise characteristics
4. Depth of free water surface in the bed
5. Cover soil and vegetation
6. Construction techniques
7. Salt accumulation (ET only)
8. Soil permeability (ETA only)

As noted previously, climate has a significant effect on the application and performance of ET and ETA systems. Solar radiation, temperature, humidity, wind speed, and precipitation all influence performance. Since these parameters fluctuate from day to day, season to season, and year to year, evaporation rates also vary substantially. To insure adequate overall performance, these fluctuations must be considered in the design.

The hydraulic loading rate of an ET bed affects performance. Too high a loading rate results in discharge from the bed; too low a loading rate results in a lower gravity (standing) water level in the bed and inefficient utilization. Several researchers noted decreased evaporation rates with decreased water levels (33)(34)(35). This problem can be overcome by sectional construction in level areas to maximize the water level in a portion of the bed, and by serial distribution for sloping sites.

The capillary rise characteristic of the sand used to fill the ET bed is important since this mechanism is responsible for transporting the water to the surface of the bed. Thus, the sand needs to have a capillary rise potential at least as great as the depth of the bed, and yet should not be so fine that it becomes clogged by solids in the applied wastewater (33).

Significant seasonal fluctuations in the free water surface are normal, necessitating the use of vegetation that is tolerant to moisture extremes. A variety of vegetation, including grasses, alfalfa, broad-leaf trees, and evergreens, have been reported to increase the average annual evaporation rate from an ET bed to above that for bare soil (35). However, grasses and alfalfa also result in nearly identical or reduced evaporation rates as compared to bare soil in the winter and the spring when evaporation rates are normally at a minimum (33)(34). Similarly, top soil has been reported to reduce evaporation rates. Certain evergreen shrubs, on the other hand, have been shown to produce slightly greater evaporation rates than bare soil throughout the year (33). Thus, there are conflicting views on the benefits of cover soil and vegetation.

Although ET system performance is generally affected less by construction techniques than most subsurface disposal methods, some aspects of ET construction can affect performance. Insuring the integrity of the impermeable liner and selecting the sand to provide for maximum capillary rise properties are typically the most important considerations. For ETA systems, the effects of construction techniques are similar to those discussed previously with reference to subsurface disposal systems in slowly permeable soils.

Salt accumulation in ET disposal systems occurs as wastewater is evaporated. Salt accumulation is particularly pronounced at the surface of the bed during dry periods, although it is redistributed throughout the bed by rainfall. Experience to date indicates that salt accumulation does not interfere with the operation of nonvegetated ET systems (39) (40). For ET systems with surface vegetation, salt accumulation may adversely affect performance after a long period of use, although observations of ET systems that have been in operation for 5 years indicate no significant problems (33). In order to minimize potential future problems associated with salt accumulation, the ET or ETA piping system may be designed to permit flushing of the bed.

Since ETA systems utilize seepage into the soil as well as evaporation for wastewater disposal, soil permeability is also a factor in the performance of these systems. Discussion of this factor relative to subsurface disposal systems (Section 7.2) applies here.

Data that quantitatively describe performance are not available for ET or ETA disposal. However, the technical feasibility of nondischarging ET disposal has been demonstrated under experimental conditions (33) (34). In addition, observations of functioning ET systems indicate that adequate performance can be achieved at least in semiarid and arid areas. The performance of ETA systems depends primarily on the relationship between climate and soil characteristics, and has not been quantified. However, the technical feasibility of such systems is well accepted.

7.3.2.5 Design

ET and ETA systems must be designed so that they are acceptable in performance and operation. Requirements for acceptability vary. On one hand, acceptable performance can be defined for an ET system as zero discharge for a specified duration such as 10 years, based on the weather data for a similar period. Alternatively, occasional seepage or surface overflow during periods of heavy rainfall or snowmelt may be allowed. In addition, physical appearance requirements for specific types of vegetation and/or a firm bed surface for normal yard use (necessitating a maximum gravity water level approximately 10 in. [25 cm] below the surface) may also be incorporated in the criteria.

Appropriate acceptance criteria vary with location. For example, occasional discharge may be acceptable in low-density rural areas, whereas completely nondischarging systems are more appropriate in higher density suburban areas. Thus, acceptance criteria are usually defined by local health officials to reflect local conditions (33).

Since the size (and thus the cost) of ET and ETA systems are dependent on the design hydraulic loading rate, any reduction in flow to those systems is beneficial. Therefore, flow reduction devices and techniques should be considered an integral part of an ET or ETA system.

The design hydraulic loading rate is the principal design feature affected by the acceptance criteria. Where a total evaporation system is required, the loading rate must be low enough to prevent the bed from filling completely. Some discrepancy in acceptable loading rates has been reported. Although reports of system designs based on higher loading rates have been presented in the literature (35)(37), other data obtained under controlled conditions indicate that pan evaporation must exceed precipitation in all months of a wet year (based on at least 10 years of data) if a total, year-round evaporation system is used. Under these conditions, loading rates between 0.03 and 0.08 gpd/ft² (1.2 and 3.3 l/m²/day) were found to be appropriate in western states (Colorado and Arizona) (33)(34).

The hydraulic loading rate is determined by an analysis of the monthly net ET ([pan evaporation x a local factor] minus precipitation) experienced in the wettest year of a 10-year period. Ten years of data should be analyzed, as very infrequent but large precipitation events may be experienced over the life of the system that would result in very infrequent discharge. Where occasional discharge from an ET system is acceptable, loading rates may be determined on a less restrictive basis, such as minimum monthly net ET in a dry year. If the unit is used for seasonal application, then only those months of occupancy will constitute the basis for design.

The loading rate for ETA systems is determined in the same manner, except that an additional factor to account for seepage in the soil is included. Thus, the loading rate for an ETA system is generally greater than the loading rate for an ET system in the same climate. The available data indicate that ETA systems can be used with a wider range of climatic conditions. For example, if soil can accept 0.2 gpd/ft² (8.1 l/m²/day), and the minimum monthly net ET is zero (determined as necessary according to the acceptance criteria), the loading rate for design is also 0.2 gpd/ft² (8.1 l/m²/day).

In addition to loading rates, the designer must also consider selection of fill material, cover soil, and vegetation. The role of vegetation in providing additional transpiration for ET systems is uncertain at this time. During the growing season, the impact of vegetation could be significant. However, during the nongrowing season, the effect of vegetation has not been well documented. Sand available for ET and ETA bed construction should be tested for capillary rise height and rate before one is selected. In general, clean and uniform sand in the size of D₅₀ = 0.1 mm (50% by weight smaller than or equal to 0.1 mm) is desirable (33).

The assumptions for a sample ET bed design are given below:

1. Four occupants of home
2. 45-gpcd design flow (no in-home water reduction)
3. Location: Boulder, Colorado
4. Critical months: December 1976 (see Figure 7-36)
5. Precipitation: 0.01 in./day (0.25 mm/day)
6. Pan evaporation: 0.07 in./day (1.7 mm/day)

An ET bed must be able to evaporate the household wastewater discharged to it as well as any rain that falls on the bed surface. Thus, the design of an ET system is based on the estimated flow from the home and the difference between the precipitation rate and the evaporation rate

FIGURE 7-36

CURVE FOR ESTABLISHING PERMANENT HOME LOADING RATE FOR BOULDER, COLORADO
BASED ON WINTER DATA, 1976-1977(33)

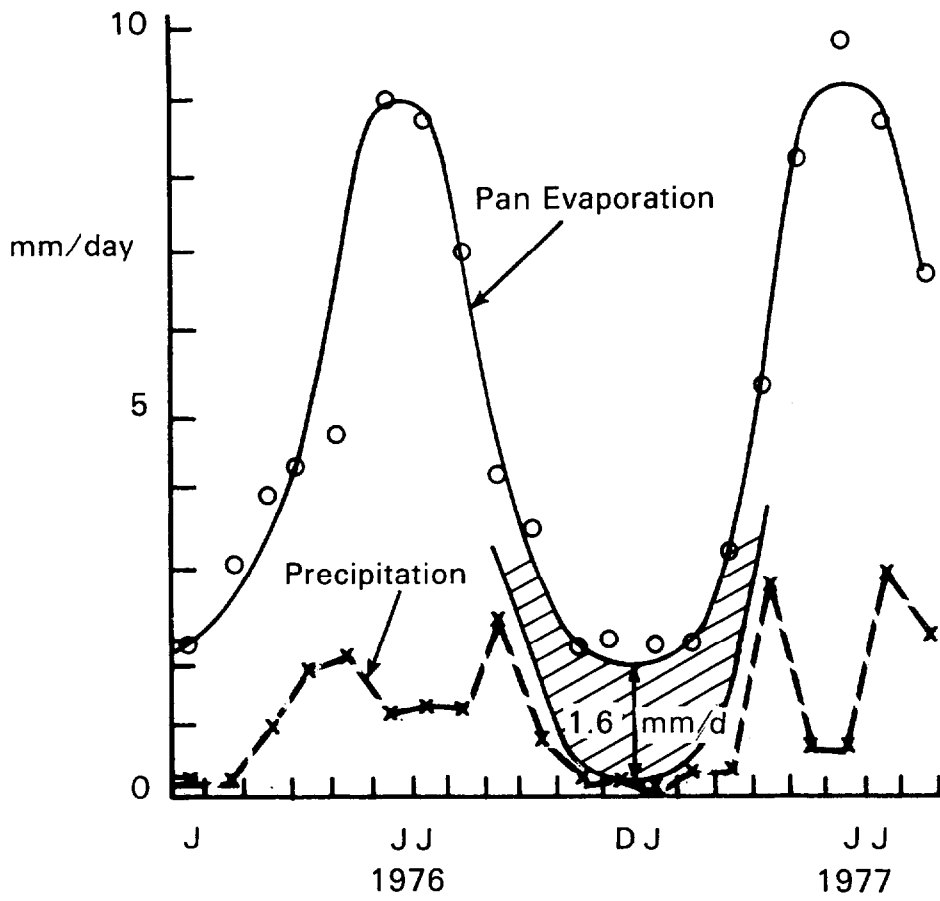

during the critical months of the year. In this example, we are assuming an average household flow of 4 persons x 45 gcpd, or 180 gpd total. Past work has shown that actual evaporation from an ET system is approximately the same as the measured pan evaporation rate in winter (33). Summer rates are approximately 70% of the measured pan evaporation rates in this area, but excessive evaporation potential more than offsets this condition. Therefore, the design is based on pan evaporation (in./day) minus precipitation (in./day). In this example,

$$(0.07 \text{ in./day}) - (0.01 \text{ in./day}) = 0.06 \text{ in./day}$$

This equates to a rate of 0.04 gpd/ft².

In this example, then, the required area for the ET bed is finally calculated:

$$\frac{180 \text{ gpd}}{0.04 \text{ gpd/ft}^2} = 4,500 \text{ ft}^2$$

To allow a factor of safety, the size could be increased to as much as 7,500 ft² based on 75 gpcd. A more realistic size would be 5,000 to 6,000 ft², which would insure no overflows. If water conservation is practiced, direct significant savings in size and costs could be achieved.

7.3.2.6 Construction Features

A typical ET bed installation was shown previously in Figure 7-35. Characteristics of an ETA bed are identical except that the liner is omitted. Limited data are available on optimum construction features for ET and ETA disposal units. The following construction features are desirable:

1. Synthetic liners should have a thickness of at least 10 mil; it may be preferable to use a double thickness of liner material so that the seams can be staggered if seams are unavoidable.
2. Synthetic liners should be cushioned on both sides with layers of sand at least 2 in. (5 cm) thick to prevent puncturing during construction.
3. Surface runoff from adjacent areas should be diverted around the system by berms or drainage swales.

4. Crushed stone or gravel placed around the distribution pipes should be 3/4 to 2-1/2 in. (2 to 6 cm).
5. Filter cloth or equivalent should be used on top of the rock or gravel to prevent sand from settling into the aggregate, thus reducing the void capacity.
6. Care should be exercised in assembling the perforated distribution pipes (4 in. [10 cm]) to prevent pipe glues and solvents from contacting the synthetic liner.
7. The bed surface should be sloped for positive drainage.
8. A relatively porous topsoil, such as loamy sand or sandy loam, should be used if required to support vegetation to prevent erosion, or to make the appearance more acceptable.
9. The bed should be located in conformance with local code requirements.
10. Construction techniques described previously for subsurface disposal systems, where soil permeability may be decreased by poor construction practices, should be used for ETA systems (39)(40)(41).

7.3.2.7 Operation and Maintenance

Routine operation and maintenance of an ET or ETA disposal unit consists only of typical yard maintenance activities such as vegetation trimming. Pretreatment units and appurtenances require maintenance as described in Chapter 8. Unscheduled maintenance requirements are rare, and stem mainly from poor operating practices such as failure to pump out septic tank solids.

7.3.2.8 Considerations for Multi-Home and Commercial Wastewaters

ET systems may be applicable to small housing clusters and commercial/institutional establishments, but large area requirements may limit their practicality. Adjustments in the type of pretreatment used may be required depending on the wastewater characteristics. For example, a grease trap is normally required prior to septic tank or aerobic treatment of restaurant wastewater disposed of in an ET system.

7.3.3 Evaporation and Evaporation/Infiltration Lagoons

7.3.3.1 Description

Lagoons have found widespread application for treatment of municipal wastewater from small communities, and have occasionally been used for wastewater treatment in onsite systems prior to discharge to surface waters. A more common application in onsite systems has been for treatment and subsequent disposal by evaporation, or a combination of evaporation and infiltration.

A discussion of evaporation and evaporation/infiltration lagoons is provided, since thousands are currently in use across the United States. However, performance data are very limited. The information provided in this section is based on current practice without assurance that such practice is optimal.

7.3.3.2 Application

In the United States, an evaporation or evaporation/infiltration lagoon could be used in most locations that have enough available land. However, local authorities typically prefer or require the use of subsurface disposal systems where conditions permit. Thus, actual application of these lagoons is generally limited to rural areas where subsurface disposal is not possible. In addition, use of evaporation/infiltration lagoons is not appropriate in areas where wastewater percolation might contaminate groundwater supplies, such as in areas of shallow or creviced bedrock, or high water tables. Use of both types of lagoons, especially evaporation lagoons, is favored by the large net evaporation potentials found in arid regions.

Data on the impact of influent wastewater characteristics on evaporation and evaporation/infiltration lagoons are very limited. Pretreatment is desirable, especially if a garbage grinder discharges to the system.

7.3.3.3 Factors Affecting Performance

The major climatic factors affecting performance of evaporation and evaporation/infiltration lagoons include sunlight, wind circulation,

humidity, and the resulting net evaporation potential. Other features that affect performance include:

1. Soil permeability (evaporation/infiltration only)--lagoon size and soil permeability are inversely proportional
2. Salt accumulation (evaporation only)--results in decreased evaporation rate
3. Hydraulic loading--size must accommodate peak flows
4. Inlet configuration--center inlet tends to improve mixing and minimize odors
5. Construction techniques

7.3.3.4 Design

Lagoons can be circular or rectangular. The maximum wastewater depth is normally 3 to 5 ft (0.9 to 1.5 m) with a freeboard of 2 or 3 ft, (0.6 to 0.9 m), although depths greater than 8 ft (2.4 m) have also been used (42)(43)(44)(45)(46)(47). The minimum wastewater depth is generally 2 ft (0.6 m). This may necessitate the addition of fresh water during high-evaporation summer months. Figure 7-37 shows the dimensional requirements for a typical onsite lagoon. The size ranges from 3 to 24 ft²/gpcd (0.07 to 0.57 m²/lpcd), depending primarily on the type of lagoon (evaporation or evaporation/infiltration), soil permeability, climate, and local regulations.

Lagoon design is usually based on locally available evaporation and precipitation data, soil percolation rates (evaporation/infiltration only), and an assumed wastewater flow. Since runoff is excluded by the containment berms, evaporation lagoons need only provide adequate surface area to evaporate the incident precipitation and the influent wastewater. Calculations may be made initially on an annual basis, but must then be checked to insure that adequate volume is provided for storage during periods when liquid inputs exceed evaporation. A brief design example is outlined below.

Assumptions:

1. Four occupants of home
2. 45-gpcd wastewater flow
3. Annual precipitation: 15.3 in.
4. Annual evaporation: 46.7 in.

FIGURE 7-37

TYPICAL EVAPORATION/INFILTRATION LAGOON FOR SMALL INSTALLATIONS

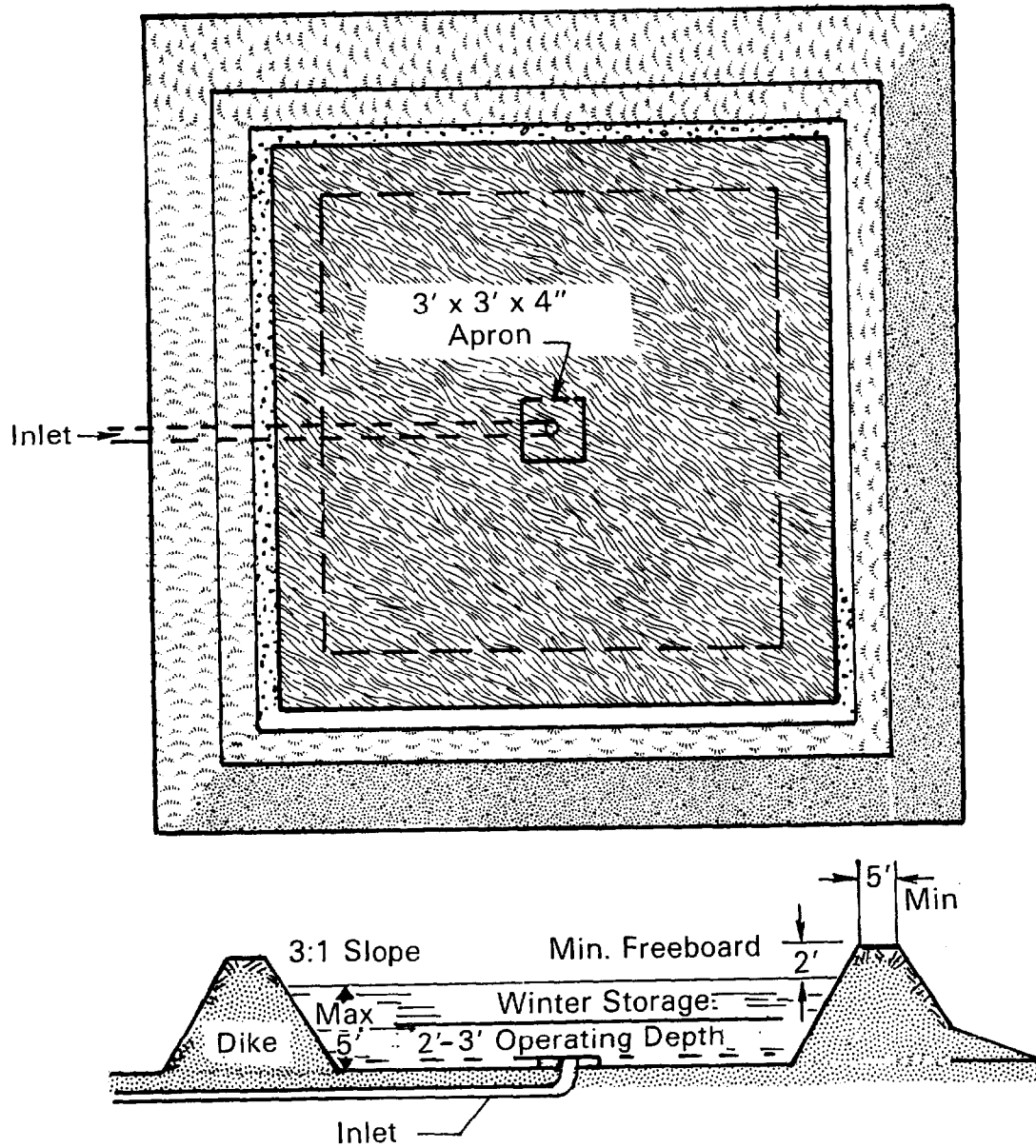

Design flow:

$$4 \text{ persons} \times 45 \text{ gpcd} = 180 \text{ gpd}$$

Net evaporation per year:

$$46.7 \text{ in.} - 15.3 \text{ in.} = 31.4 \text{ in.}$$

$$(31.4 \text{ in.})(144 \text{ in.}^2) = 4,522 \text{ in.}^3 \text{ of water/ft}^2 \text{ water surface}$$

$$(4,522 \text{ in.}^3)(\text{ft}^3/1,728 \text{ in.}^3)(7.48 \text{ gal/ft}^3) = 19.6 \text{ gal of water/ft}^2 \text{ water surface}$$

Lagoon area required:

$$(180 \text{ gpd})(365 \text{ days})/(19.6 \text{ gal/ft}^2) = 3,352 \text{ ft}^2$$

This can be provided by a round lagoon, 65.3-ft diameter.

At this point, we need to ensure that the lagoon will have adequate storage capacity to allow accumulation of water to a depth of no more than 4 or 5 ft in low-evaporation months (usually winter), and to allow sufficient surface area for evaporation of the accumulated water plus new influent flows during the months when evaporation rates exceed the monthly wastewater flow (usually summer). This is done by comparing the wastewater flow against the evaporation rate for each months, and by performing a water balance (i.e., calculating the gain or loss in gallons for each months). Table 7-16 shows such a balance.

From October through April, the lagoon will gain 35,443 gal of volume. This is equivalent to a gain of 1.4 ft:

$$(35,443 \text{ gal})\left(\frac{1}{3,352 \text{ ft}^2}\right)\left(\frac{\text{ft}^3}{7.48 \text{ gal}}\right) = 1.4 \text{ ft}$$

Beginning with a 2-ft minimum depth, the depth of the lagoon varies from 2 ft to 3.4 ft.

Some sources indicate that BOD loadings should also be considered in lagoon sizing for odor control. Loadings in the range of 0.25 to 0.8 #BOD/day/1,000 ft² (1.2 to 3.9 kg/day/1000 m²) have been recommended, but supporting data for onsite systems are not available (43)(45)(46). If infiltration is permitted and feasible considering local soils, the size of the lagoon can be reduced by the amount of water lost through percolation.

TABLE 7-16

SAMPLE WATER BALANCE FOR EVAPORATION LAGOON DESIGN

Month	Influent gal	Precip. in.	Evap. in.	Precipitation ^a -Evaporation		Net ^b Flow gal	Cum. Volume gal
				in.	gal		
October	5580	1.1	2.2	-1.1	- 2299	3281	3281
November	5400	1.4	1.8	-0.4	- 836	4564	7845
December	5580	1.8	1.7	0.1	209	5789	13634
January	5580	1.6	0.7	0.9	1881	7461	21095
February	5040	1.6	0.9	0.7	1463	6503	27598
March	5580	1.4	1.2	0.2	418	5998	33596
April	5400	1.4	3.1	-1.7	- 3553	1847	35443
May	5580	1.2	5.3	-4.1	- 8569	- 2989	32454
June	5400	1.2	6.1	-4.9	-10241	- 4841	27613
July	5580	0.8	9.4	-8.6	-17974	-12394	15219
August	5580	0.8	9.0	-8.2	-17138	-11558	3661
September	5400	1.0	5.3	-4.3	- 8987	- 3587	74
	<u>65700</u>	<u>15.3</u>	<u>46.7</u>				

$$\begin{aligned}
 \text{a } [\text{Precip.} - \text{Evap. (gal)}] &= [\text{Precip.} - \text{Evap. (in.)}] \times (3352 \text{ ft}^2) \times (7.48 \text{ gal/ft}^3) \times (1/12) \\
 &= 2090 \times [\text{Precip.} - \text{Evap. (in.)}]
 \end{aligned}$$

$$\text{b Net Flow} = (\text{Influent}) + (\text{Precip.} - \text{Evap.})$$

Other design features which are frequently incorporated include fencing, center inlet, specific berm slopes, and buffer zones. Five- or 6-ft (1.5- to 1.8-m) high fencing is preferred to limit animal and human intrusion. Submerged center inlets are recommended to facilitate mixing, to provide even solids deposition, and to minimize odors. Interior berm slopes, steep enough to minimize rooted aquatic plant growth in the lagoon, but resistant to erosion, are desirable. Slopes sufficient to accomplish this objective have been reported to be between 3:1 and 2:1, depending primarily on height and soil characteristics. Buffer zones are normally controlled by local regulations, but typically range from 100 to 300 ft (30 to 91 m).

7.3.3.5 Construction Features

To prevent seepage through the berm in unlined lagoons, a good interface between the berm and the native soil is necessary. In areas where the use of subsurface disposal systems is restricted due to slowly permeable soils, B-horizon soils are frequently appropriate for berm construction. Excavation of the topsoil prior to berm placement (so that the base of the berm rests on the less permeable subsoils) reduces the incidence of seepage, as does compaction of the berm material during placement. For evaporation lagoons, care during construction to insure placement of a leak-free liner reduces the need for impermeable berm material and associated construction precautions.

7.3.3.6 Operation and Maintenance

Start-up of a lagoon system requires filling the lagoon from a convenient freshwater source to a depth of at least 2 ft (0.6 m). This initial filling helps to prevent rooted plant growth and septic odors.

Solids removal is required periodically for evaporation lagoons. Data are not available to indicate the exact frequency of solids removal required, but intervals of several years between pump-outs can be anticipated.

The reported need for chemical addition to control odors, insects, rooted plants, and microbial growth varies on a case-by-case basis with climate, lagoon location and configuration, and loading rate. Maintenance of a minimum 2-ft (0.6-m) wastewater depth in the lagoon, and frequent trimming of vegetation on the berm and in the vicinity of the lagoon, are suggested. No other maintenance is required.

7.3.3.7 Seasonal, Multifamily, and Commercial Applications

Use of evaporation and evaporation/infiltration lagoons for summer homes would result in somewhat reduced area requirements per gallon of wastewater handled, since storage would not need to be provided during the winter months. Otherwise, application of these systems to seasonal dwellings is comparable to year-round residences.

Evaporation and evaporation/infiltration lagoons are also applicable to multifamily and commercial applications, although additional pretreatment may be required depending on the wastewater characteristics.

7.4 Outfall to Surface Waters

Direct discharge of onsite treatment system effluent is a disposal option if an appropriate receiving water is available and if the regulatory agencies permit such a discharge. The level of treatment required varies, depending on local regulations, stream water quality requirements, and other site-specific conditions. In general, onsite treatment system effluent disposed by surface discharge must at least meet secondary treatment standards for publicly owned treatment works. Depending on site-specific conditions, more stringent BOD and SS discharge requirements and/or limitations on N and P discharges may be applicable.

The performance, operation, and maintenance requirements, and the environmental acceptability of the surface discharge depend predominantly on the preceding treatment system. Operation and maintenance associated specifically with the surface discharge pipe are minimal in a gravity situation. If the effluent must be pumped, then routine pump maintenance will be required.

Discharge pipes should be made of corrosion- and crush-resistant materials such as cast iron or rigid plastic pipe. For single-family systems, the pipe should range from 2 to 4 in. (5 to 10 cm) in diameter, should be buried, and should be moderately sloped (between 0.5 and 3%). Steep slopes may cause washout at the discharge point.

7.5 References

1. Bendixen, T. W., M. Berk, J. P. Sheehy, and S. R. Weibel. Studies on Household Sewage Disposal Systems, Part II. NTIS Report No. PB 216 128, Environmental Health Center, Cincinnati, Ohio, 1950. 96 pp.

2. Bouma, J. Unsaturated Flow During Soil Treatment of Septic Tank Effluent. J. Environ. Eng. Div., Am. Soc. Civil Eng., 101:996-983, 1975.
3. Manual of Septic Tank Practice. Publication No. 526, Public Health Service, Washington, D.C., 1967. 92 pp.
4. Small Scale Waste Management Project, University of Wisconsin, Madison. Management of Small Waste Flows. EPA 600/2-78-173, NTIS Report No. PB 286 560, September 1978. 804 pp.
5. Laak, R. Pollutant Loads From Plumbing Fixtures and Pretreatment to Control Soil Clogging. J. Environ. Health, 39:48-50, 1976.
6. Winneberger, J. H., L. Francis, S. A. Klein, and P. H. McGauhey. Biological Aspects of Failure of Septic Tank Percolation Systems; Final Report. Sanitary Engineering Research Laboratory, University of California, Berkeley, 1960.
7. Winneberger, J. T., and J. W. Klock. Current and Recommended Practices for Subsurface Waste Water Disposal Systems in Arizona. Engineering Research Center Report No. ERC-R-73014, College of Engineering Service, Arizona State University, Tempe, 1973.
8. Subsurface Wastewater Disposal Regulations. Plumbing Code, Part II. Department of Human Services, Division of Health Engineering, Augusta, Maine, 1978.
9. Weibel, S. R., T. W. Bendixen, and J. B. Coulter. Studies on Household Sewage Disposal Systems, Part III. NTIS Report No. PB 217 415, Environmental Health Center, Cincinnati, Ohio, 1954. 150 pp.
10. Corey, R. B., E. J. Tyler, and M. V. Olotu. Effects of Water Softener Use on the Permeability of Septic Tank Seepage Fields. In: Proceedings of the Second National Home Sewage Treatment Symposium, Chicago, Illinois, December 1977. American Society of Agricultural Engineers, St. Joseph, Michigan, 1978. pp. 226-235.
11. Machmeier, R. E. Town and Country Sewage Treatment. Bulletin 304, University of Minnesota, St. Paul, Agricultural Extension Service, 1979.
12. Otis, R. J., G. D. Plews, and D. H. Patterson. Design of Conventional Soil Absorption Trenches and Beds. In: Proceedings of the Second National Home Sewage Treatment Symposium, Chicago, Illinois, December 1977. American Society of Agricultural Engineers, St. Joseph, Michigan, 1978. pp. 86-99.

13. McGauhey, P. H., and J. T. Winneberger. Final Report on a Study of Methods of Preventing Failure of Septic Tank Percolation Systems. SERL Report No. 65-17, Sanitary Engineering Research Laboratory, University of California, Berkeley, 1965. 33 pp.
14. Bendixen, T. W., J. B. Coulter, and G. M. Edwards. Study of Seepage Beds. Robert A. Taft Sanitary Engineering Center, Cincinnati, Ohio, 1960.
15. Bouma, J., J. C. Converse, and F. R. Magdoff. Dosing and Resting to Improve Soil Absorption Beds. Trans. Am. Soc. Civ. Eng., 17:295-298, 1974.
16. Harkin, J. M., and M. D. Jawson. Clogging and Unclogging of Septic System Seepage Beds. In: Proceedings of the Second Illinois Private Sewage Disposal System, Champaign, Illinois, 1977. Illinois Department of Public Health, Springfield. pp. 11-21.
17. Otis, R. J., J. C. Converse, B. L. Carlile, and J. E. Witty. Effluent Distribution. In: Proceedings of the Second National Home Sewage Treatment Symposium, Chicago, Illinois, December 1977. American Society of Agricultural Engineers, St. Joseph, Michigan, 1978. pp. 61-85.
18. Kropf, F. W., R. Laak, and K. A. Healey. Equilibrium Operation of Subsurface Absorption Systems. J. Water Pollut. Control Fed., 49:2007-2016, 1977.
19. Otis, R. J. An Alternative Public Wastewater Facility for a Small Rural Community. Small Scale Waste Management Project, University of Wisconsin, Madison, 1978.
20. Alternatives for Small Wastewater Treatment Systems. EPA 625/4-77-011, NTIS Report No. PB 299 608, Center for Environmental Research Information, Cincinnati, Ohio, 1977.
21. Bendixen, T. W., R. E. Thomas, and J. B. Coulter. Report of a Study to Develop Practical Design Criteria for Seepage Pits as a Method for Disposal of Septic Tank Effluents. NTIS Report No. PB 216 931, Cincinnati, Ohio, 1963. 252 pp.
22. Winneberger, J. T. Sewage Disposal System for the Rio-Bravo Tennis Ranch, Kern County, California. 1975.
23. Witz, R. L., G. L. Pratt, S. Vogel, and C. W. Moilanen. Waste Disposal Systems for Rural Homes. Circular No. AE 43, North Dakota State University Cooperative Extension Service, Fargo, 1974.
24. Converse, J. C., B. L. Carlile, and G. W. Peterson. Mounds for the Treatment and Disposal of Septic Tank Effluent. In: Proceedings of the Second National Home Sewage Treatment Symposium, Chicago,

- Illinois, December 1977. American Society of Agricultural Engineers, St. Joseph, Michigan, 1978. pp. 100-120.
25. Converse, J. C. Design and Construction Manual for Wisconsin Mounds. Small Scale Waste Management Project, University of Wisconsin, Madison, 1978. 80 pp.
 26. Soil Conservation Service. Drainage of Agricultural Land. Water Information Center, Port Washington, New York, 1973. 430 pp.
 27. Mellen, W. L. Identification of Soils as a Tool for the Design of Individual Sewage Disposal Systems. Lake County Health Department, Waukegan, Illinois, 1976. 67 pp.
 28. Casagrande, L. Electro-Osmotic Stabilization of Soils. J. Boston Soc. Civ. Eng., 39:51-82, 1952.
 29. On-Site Wastewater Management. National Environmental Health Association, Denver, Colorado, 1979. 108 pp.
 30. Electro-Osmosis, Inc., Minneapolis, Minnesota.
 31. Bendixen, T. W., and J. B. Coulter. Effectiveness at the Distribution Box. U.S. Public Health Service, Washington, D.C., 1958.
 32. Sheldon, W. H. Septic Tank Drainage Systems. Research Report No. 10, Farm Science Agricultural Experiment Station, Michigan State University, East Lansing, 1964.
 33. Bennett, E. R. and K. D. Linstedt. Sewage Disposal by Evaporation-Transpiration. EPA 600/2-78-163, NTIS Report NO. PB 288 588, September 1978. 196 pp.
 34. Rugen, M. A., D. A. Lewis, and I. J. Benedict. Evaporation - A Method of Disposing of Septic Tank Effluent. Edwards Underground Water District, San Antonio, Texas, (no date). 83 pp.
 35. Bernhardt, A. P. Treatment and Disposal of Wastewater from Homes by Soil Infiltration and Evapotranspiration. University of Toronto Press, Toronto, Canada, 1973. 173 pp.
 36. Pence, H. J. Evaluation of Evapotranspiration as a Disposal System for Individual Household Wastes (A Seven-State Test); Draft Report. National Science Foundation, Washington, D.C., 1979.
 37. Lomax, K. M., P. N. Winn, M. C. Tatro, and L. S. Lane. Evapotranspiration Method of Wastewater disposal. UMCEES Ref. No. 78-40, University of Maryland Center for Environmental and Estuarine Studies, Cambridge, 1978. 42 pp.

38. Bernhart, A. P. Return of Effluent Nutrients to the Natural Cycle Through Evapotranspiration and Subsoil-Infiltration of Domestic Wastewater. In: Proceedings of the National Home Sewage Disposal Symposium, Chicago, Illinois, December 1974. American Society of Agricultural Engineers, St. Joseph, Michigan, 1975. pp. 175-181.
39. Land Treatment of Municipal Wastewater Effluents. EPA 625/4-76-010, NTIS Report No. PB 259 994, Center for Environmental Research Information, Cincinnati, Ohio, 1976.
40. Jensen, M. E., H. G. Collins, R. D. Burman, A. E. Cribbs, and A. I. Johnson. Consumptive Use of Water and Irrigation Water Requirements. Irrigation Drainage Division, American Society of Civil Engineers, New York, 1974. 215 pp.
41. Priestly, C. H. B., and R. J. Taylor. On the Assessment of Surface Heat Flux and Evaporation Using Large-Scale Parameters. Mon. Weather Rev., 100:81-82, 1972.
42. Witz, R. L. Twenty-Five Years with the Nodak Waste Disposal System. In: Proceedings of the National Home Sewage Disposal Symposium, Chicago, Illinois, December 1974. American Society of Agricultural Engineers, St. Joseph, Michigan, 1975. pp. 168-174.
43. Standards for Designing a Stabilization Lagoon. North Dakota State Department of Health, Bismarck, (No date). 3 pp.
44. Pickett, E. M. Evapotranspiration and Individual Lagoons. In: Proceedings of Northwest Onsite Wastewater Disposal Short Course, University of Washington, Seattle, December 1976. pp. 108-118.
45. Standards for Subsurface and Alternative Sewage and Non-Water-Carried Waste Disposal. Oregon Administrative Rules, Chapter 340, Division 7, May 1978. p 97.
46. Hines, M. W., E. R. Bennett, and J. A. Hoehne. Alternate Systems for Effluent Treatment and Disposal. In: Proceedings of the Second National Home Sewage Disposal Symposium, Chicago, Illinois, December 1977. American Society of Agricultural Engineers, St. Joseph, Michigan, 1978. pp. 137-148.
47. Code of Waste Disposal Regulations - Part III. Utah State Department of Health, Sewers and Wastewater Treatment Works, Salt Lake City, 1977. 41 pp.

CHAPTER 8

APPURTENANCES

8.1 Introduction

This chapter discusses several types of equipment used in onsite wastewater treatment/disposal systems that have general application to the components previously presented. The following items are covered:

1. Grease traps (or grease interceptors)
2. Dosing chambers
3. Flow diversion methods

Grease traps are used to remove excessive amounts of grease that may interfere with subsequent treatment. Dosing chambers are necessary when raw or partially treated wastewater must be lifted or dosed in large periodic volumes. Flow diversion valves are used when alternating use of treatment or disposal components is employed. These components are described as to applicability, performance, design criteria, construction features, and operation and maintenance.

8.2 Grease Traps

8.2.1 Description

In some instances, the accumulation of grease can be a problem. In certain commercial/institutional applications, grease can clog sewer lines and inlet and outlet structures in septic tanks, resulting in restricted flows and poor septic tank performance. The purpose of a grease trap is simply to remove grease from the wastewater stream prior to treatment.

Grease traps are small flotation chambers where grease floats to the water surface and is retained while the clearer water underneath is discharged. There are no moving mechanical parts, and the design is similar to that of a septic tank.

The grease traps discussed here are the large, outdoor-type units, and should not to be confused with the small grease traps found on some kitchen drains.

8.2.2 Application

Grease traps are very rarely used for individual homes. Their main application is in treating kitchen wastewaters from motels, cafeterias, restaurants, hospitals, schools, and other institutions with large volumes of kitchen wastewaters.

Influents to grease traps usually contain high organic loads including grease, oils, fats, and dissolved food particles, as well as detergents and suspended solids. Sanitary wastewaters are not usually treated by grease traps. Wastewaters from garbage grinders should not be discharged to grease traps, as the high solids loadings can upset grease trap performance and greatly increase both solids accumulations and the need for frequent pumpout.

8.2.3 Factors Affecting Performance

Several factors can affect the performance of a grease trap: wastewater temperature, solids concentrations, inlet conditions, retention time, and maintenance practices.

By placing the grease trap close to the source of the wastewater (usually the kitchen) where the wastewater is still hot, grease separation and skimming (if used) are facilitated. As previously mentioned, high solids concentrations can impair grease flotation and cause a solids build-up on the bottom, which necessitates frequent pumpout. Flow control fittings should be installed on the inlet side of smaller traps to protect against overloading or sudden surges from the sink or other fixtures. These surges can cause agitation in the trap, impede grease flotation, and allow grease to escape through the outlet. Hydraulic loading and retention time can also affect performance. High loadings and short retention times may not allow sufficient time for grease to separate fully, resulting in poor removals. Maintenance practices are important, as failure to properly clean the trap and remove grease and solids can result in excessive grease buildup that can lead to the discharge of grease in the effluent.

TABLE 8-1

RECOMMENDED RATINGS FOR COMMERCIAL GREASE TRAPS (1)

<u>Type of Fixture</u>	<u>Flow Rate</u> gpm	<u>Grease Retention Capacity Rating</u> lb	<u>Recommended Maximum Capacity Per Fixture Connected to Trap</u> gal
Restaurant kitchen sink	15	30	50.0
Single-compartment scullery sink	20	40	50.0
Double-compartment scullery sink	25	50	62.5
2 single-compartment sinks	25	50	62.5
2 double-compartment sinks	35	70	87.5
Dishwashers for restaurants:			
Up to 30 gal water capacity	15	30	50.0
Up to 50 gal water capacity	25	50	62.5
50 to 100 gal water capacity	40	80	100.0

SC = Storage capacity factor -- minimum of 1.7 onsite disposal - 2.5
 LF = Loading factor -- 1.25 garbage disposal & dishwashing
 1.0 without garbage disposal
 0.75 without dishwashing
 0.5 without dishwashing and garbage disposal

^a Minimum size grease interceptor should be 750 gal

Thus, for a restaurant with a 75-seat dining area, an 8 hr per day operation, a typical discharge of 5 gal (19 l) per meal, a storage capacity factor of 1.7 and a loading factor of 0.8, the size of the grease interceptor is calculated as follows:

$$(75) \times (5) \times (1.7) \times \left(\frac{8}{24}\right) \times (0.8) = 2,040 \text{ gal (7,722 l)}$$

Other design considerations include: facilities for insuring that both the inlet and outlet are properly baffled; easy manhole access for cleaning; and inaccessibility of the trap to insects and vermin.

8.2.5 Construction Features

Grease traps are generally made of pre-cast concrete, and are purchased completely assembled. However, very large units may be field constructed. Grease traps come in single- and double-compartment versions. Figure 8-1 shows a typical pre-cast double-compartment trap (2).

Grease traps are usually buried so as to intercept the building sewer. They must be level, located where they are easily accessible for cleaning, and close to the wastewater source. Where efficient removal of grease is very important, an improved two-chamber trap has been used which has a primary (or grease-separating) chamber and a secondary (or grease-storage) chamber. By placing the trap as close as possible to the source of wastewaters, where the wastewaters are still hot, the separating grease at the surface of the first chamber can be removed by means of an adjustable weir and conveyed to the separate secondary chamber, where it accumulates, cools, and solidifies. This decreases the requirement for cleaning and allows better grease separation in the first chamber.

FIGURE 8-1

DOUBLE-COMPARTMENT GREASE TRAP

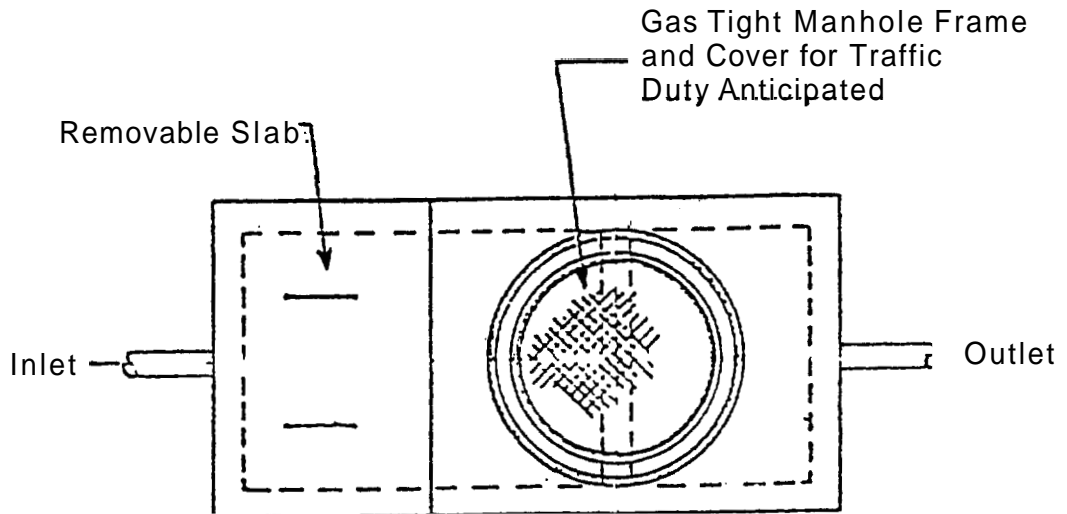

Top View

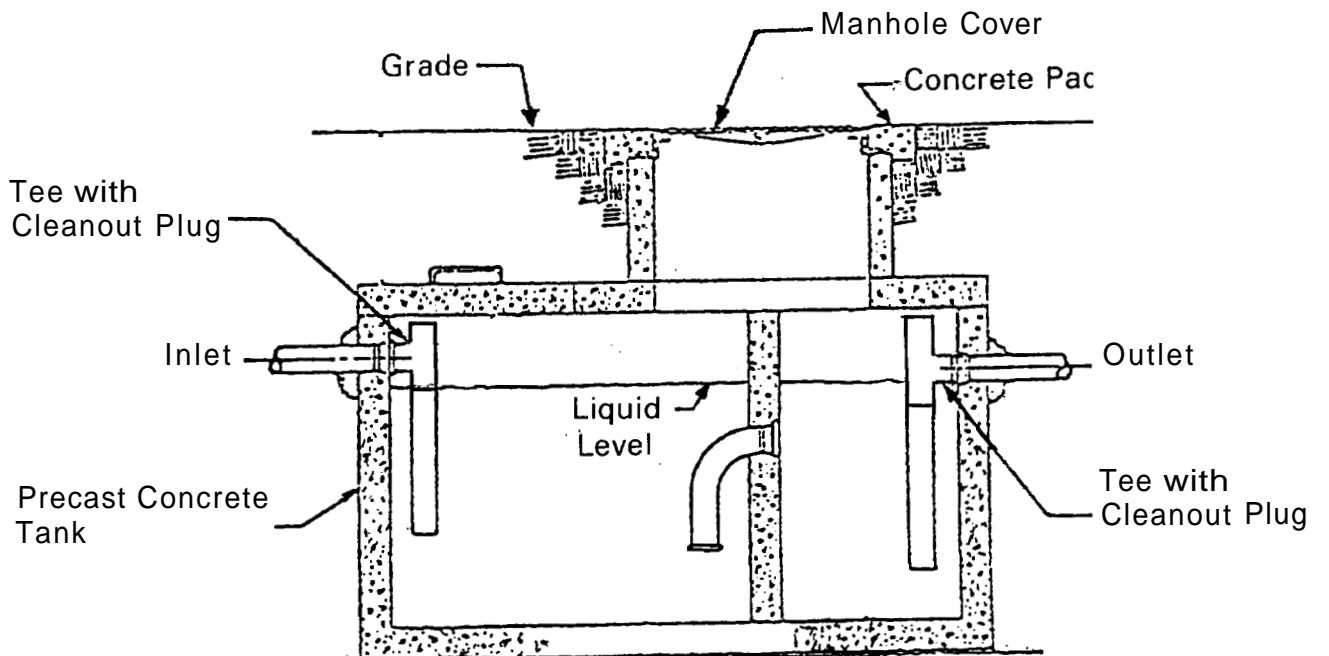

Section

The inlet, outlet, and baffle fittings are typically of "T" design with a vertical extension 12 in. (30 cm) from the tank floor and reaching well above the water line (3).

To allow for proper maintenance, manholes to finished grade should be provided. The manhole covers should be of gas-tight construction and should be designed to withstand expected loads.

A check of local ordinances and codes should always be made before the grease trap is designed or purchased.

8.2.6 Operation and Maintenance

In order to be effective, grease traps must be operated properly and cleaned regularly to prevent the escape of appreciable quantities of grease. The frequency of cleaning at any given installation can best be determined by experience based on observation. Generally, cleaning should be done when 75% of the grease-retention capacity has been reached. At restaurants, pumping frequencies range from once a week to once every 2 or 3 months.

8.3 Dosing Chambers

8.3.1 Description

Dosing chambers are tanks that store raw or pretreated wastewater for periodic discharge to subsequent treatment units or disposal areas. Pumps or siphons with appropriate switches and alarms are mounted in the tank to discharge the accumulated liquid.

8.3.2 Application

Dosing chambers are used where it is necessary to elevate the wastewater for further treatment or disposal, where intermittent dosing of treatment units (such as sand filters) or subsurface disposal fields is desired, or where pressure distribution networks are used in subsurface disposal fields. If the dosing chamber is at a lower elevation than the discharge point, pumps must be used. If the dosing chamber is at a higher elevation, siphons may be used, but only if the settleable and floatable solids have been removed from the wastewater stream.

8.3.3 Factors Affecting Performance

Factors that must be considered in design of dosing chambers are (1) the dose volume, (2) the total dynamic head, (3) the desired flow rate, and (4) the wastewater characteristics. When pumps are used, they must be selected based on all three factors. If raw wastewater with large solids is pumped, grinder pumps or pneumatic ejectors must be used. Siphons are chosen on the basis of the desired flow rate and their discharge invert elevations determined from the total dynamic head. Only wastewaters free from settleable and floatable solids can be discharged by siphons. If corrosive wastewaters such as septic tank effluent are being discharged, all equipment must be selected to withstand the corrosive atmosphere.

8.3.4 Design

8.3.4.1 Dosing Chambers with Pumps

A pumping chamber consists of a tank, pump, pump controls, and alarm system. Figure 8-2 shows a cross section of a typical pumping chamber used for pumping pretreated wastewater. The tank can be a separate unit as shown, or it can have common wall construction with the pretreatment unit.

The tank should have sufficient volume to provide the desired dosing volume, plus a reserve volume. The reserve volume is the volume of the tank between the high water alarm switch and the invert of the inlet pipe. It provides storage during power outages or pump failure. A reserve capacity equal to the estimated daily wastewater flow is typically used for residential application (4). In large flow applications, duplex pump units can be used as an alternative to provide reserve capacity. No reserve capacity is necessary when siphons are used.

Pump selection is based on the wastewater characteristics, the desired discharge rate, and the pumping head. Raw wastewater requires a pump with solids-handling capabilities. Grinder pumps, pneumatic ejectors, or solids-handling centrifugal pumps are suitable for these applications. While pneumatic ejectors may be used in other applications as well, submersible centrifugal pumps are best suited where large volumes are to be pumped in each dose.

The pump size is determined from pump performance curves provided by the manufacturers. Selection is based on the flow rate needed and the pumping head. The specific application determines the flow rate needed.

FIGURE 8-2

TYPICAL DOSING CHAMBER WITH PUMP

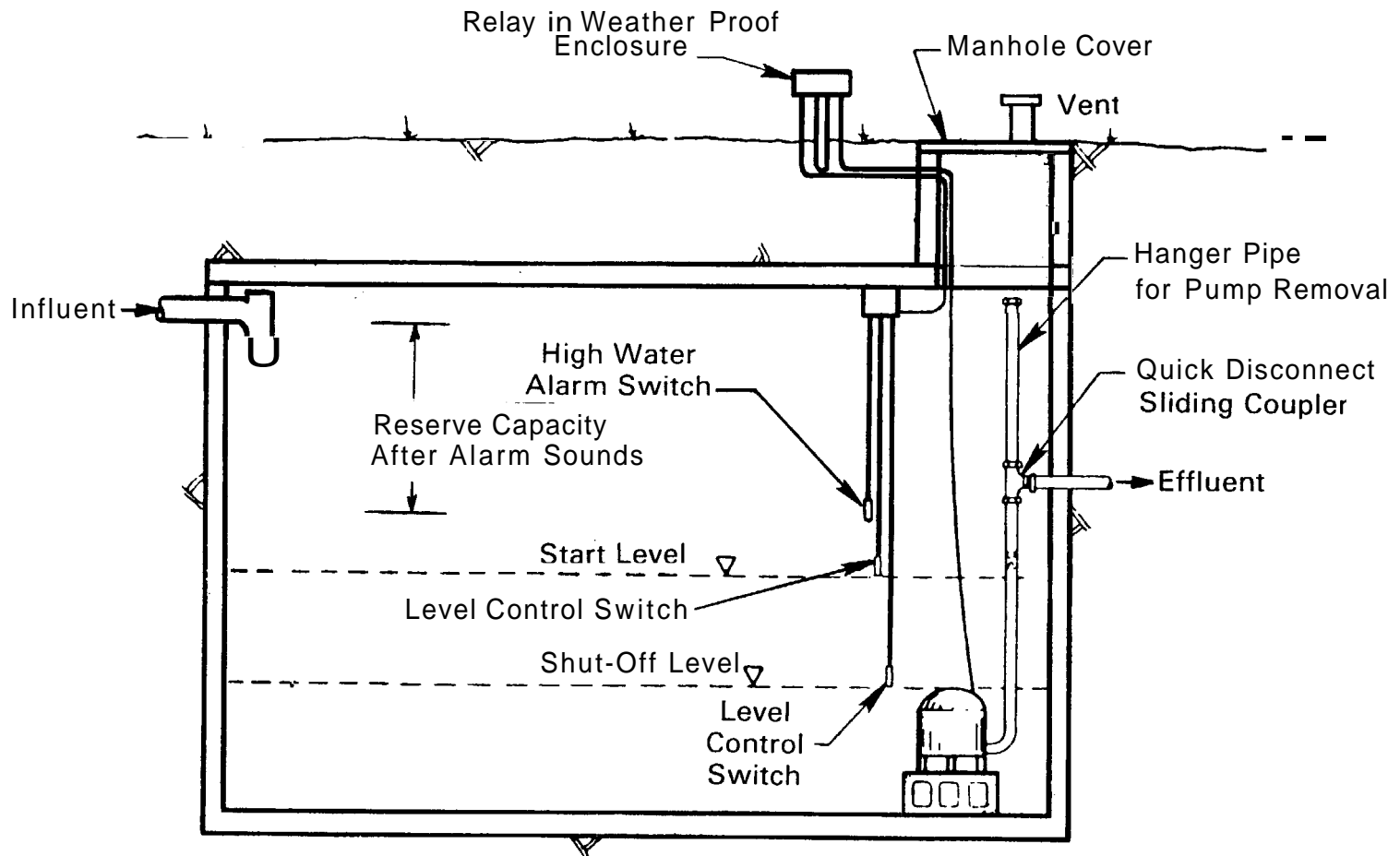

The pumping head is calculated by adding the elevation difference between the discharge outlet and the average or low water level in the dosing chamber to the friction losses incurred in the discharge pipe. The velocity head can be neglected in most applications.

If the liquid pumped is to be free from suspended solids, the pump may be set on a pedestal. This provides a quiescent zone below the pump where any solids entering the chamber can settle, thus avoiding pump damage or malfunction. These solids must be removed periodically.

In cold climates where the discharge pipe is not buried below the frost line, the pipe should be drained between doses. This may be done by sloping the discharge pipe back to the dosing chamber and eliminating the check valve at the pump. In this manner, the pipe is able to drain back into the dosing chamber through the pump. The dosing volume is sized to account for this backflow. Weep holes may also be used if the check valve is left in place.

The control system for the pumping chamber consists of a "pump off" switch, a "pump on" switch, and a high water alarm switch. The pump off switch is set several inches above the pump intake. The pump on switch is set above the pump off switch to provide the proper dosing volume. Several inches above the pump on switch, a high water alarm switch is set to alert the owner of a pump malfunction by activating a visual and/or audible alarm. This switch must be on a circuit separate from the pump switches.

The switches should withstand the humid and other corrosive atmosphere inside the tank. Pump failures can usually be traced to switch failures resulting in pump burn out, so high quality switches are a good investment. Some types are:

1. Mercury: Two basic types are available. One is an on-off switch sealed within a polyethylene float suspended from the top of the chamber by its power cord. Two switches are necessary to operate the pump (See Figure 8-3). The elevations are adjusted individually. Differential switches are also available to turn the pump on and off with one switch, but these lack the ability to adjust the dosing volume.

FIGURE 8-3
LEVEL CONTROL SWITCHES

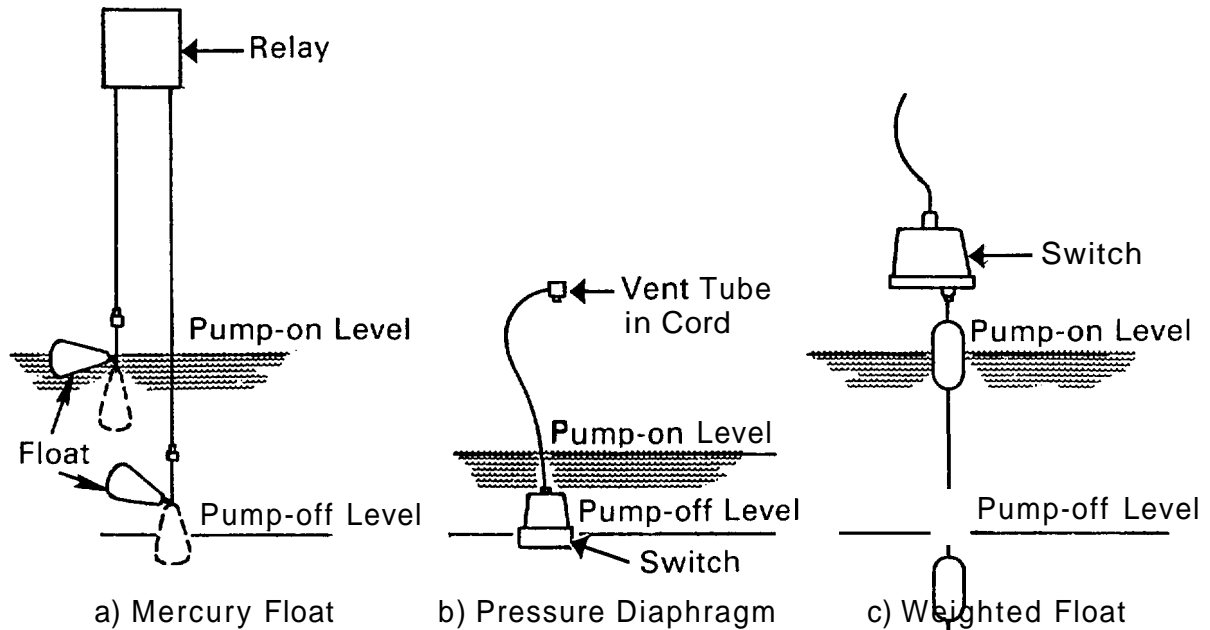

2. **Pressure Diaphragm:** The pressure diaphragm switch is a microswitch mounted behind a neoprene diaphragm. The microswitch side of the diaphragm is vented to the atmosphere by means of a vent tube imbedded in the power cord. The other side is submerged in the liquid. As the liquid level rises and falls, the pressure on the diaphragm activates the switch (See Figure 8-3). Thus, one switch is sufficient to operate the pump; but the differential in liquid levels is usually limited to about 6 in, although switches with larger differentials can be purchased. If used in pumping chambers, the vent tube must be located outside the pumping chamber or the humid atmosphere in the chamber can cause the switch to corrode.
3. **Weighted Float:** The switch is mounted above the water with 2 weights attached to a single cable hanging from the switch (See Figure 8-3). When the weights are hanging free, the switch is held open; but as the liquid level rises, the weights are buoyed up, closing the switch when the second weight is submerged. The switch is held closed by a magnet; but as the

liquid level drops, the weights lose their buoyancy and open the switch when the bottom weight is exposed. The dosing volume can be changed by adjusting the spacing between the floats.

All electrical contacts and relays must be mounted outside the chamber to protect them from corrosion. Provisions should be made to prevent the gases from following the electrical conduits into the control box.

8.3.4.2 Dosing Chambers with Siphons

Siphons may be used in place of pumps if the point of discharge is at a lower elevation than the outlet of the pretreatment unit. A chamber employing siphons consists of only a tank and the siphon. No mechanical or electrical controls are necessary, since the siphon operation is automatic. A typical siphon chamber is illustrated in Figure 8-4. Two siphons may be placed in a tank and automatically alternate, providing a simple method of dividing the wastewater flow between two treatment or disposal units.

The design of the dosing chamber is determined by the siphon selected and the head against which it must operate. The size of the siphon is determined by the average flow rate desired. The manufacturer specifies the "drawing depth," or the depth from the bottom of the siphon bell to the high water level necessary to activate the siphon (See Figure 8-4). The length and width of the chamber are determined by the dosing volume desired.

Siphon capacity is rated when discharging into the open atmosphere. Therefore, if the discharge is into a long pipe or pressure distribution network, the headlosses must be calculated and the invert at the siphon discharge set at that distance above the outlet. For high discharge rates or where the discharge pipe is very long, the discharge pipe should be one nominal pipe size larger than the siphon to facilitate air venting.

The siphons may be cast iron or fiberglass. Cast iron siphons are the most common. Their advantage is that the bell is merely set on the discharge pipe so they may be easily removed and inspected. They are subject to corrosion, however. Fiberglass siphons do not corrode, but because of their light weight, they must be bolted to the chamber floor.

FIGURE 8-4

TYPICAL DOSING CHAMBER WITH SIPHON

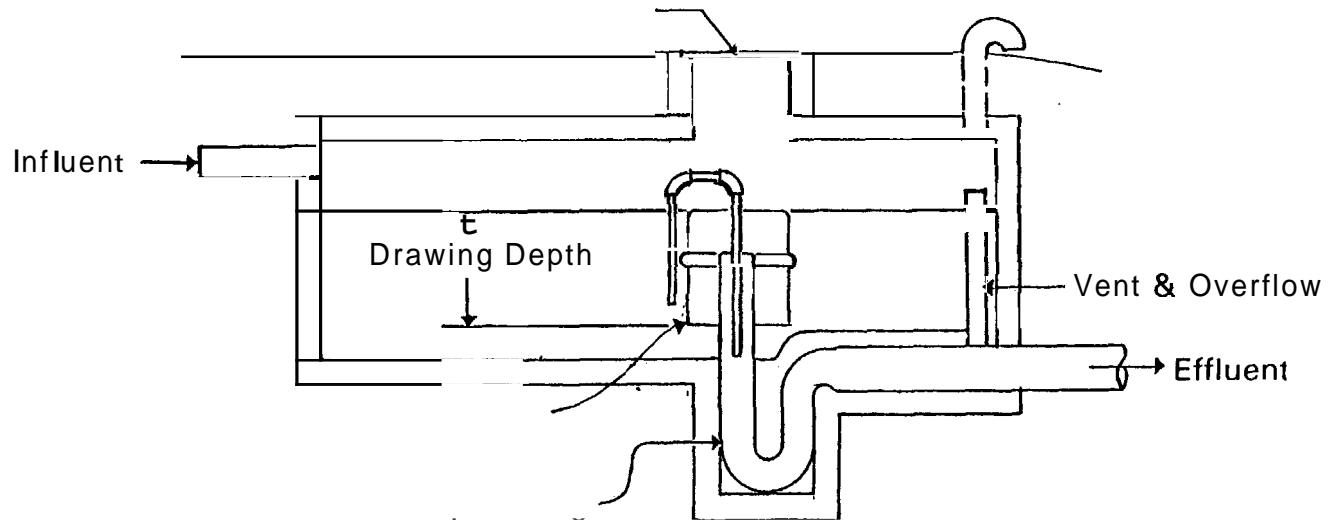

8.3.5 Construction

The tank must be watertight so groundwater does not infiltrate it. Waterproofing consists of adequately sealing all joints with asphalt or other suitable material. Coating the outside of the tank prevents groundwater from seeping into the tank. Asphalt coating the inside and outside of steel tanks helps retard corrosion. Application of 4-mil plastic to the wet asphalt coating protects the coating when back-filling.

At high water table sites, precautions should be taken so the chamber does not float out of position due to hydrostatic pressures on a near-empty tank. This is not normally a problem for concrete tanks, but for the lighter-weight materials, such as fiberglass, it could present a problem. The manhole riser pipe should be a minimum of 24 in. (61 cm) in diameter and should extend 6 in. (15 cm) above ground level to keep surface water from entering the chamber.

If plastic pipe is used for the inlet or discharge, precaution should be taken to ensure that the pipe does not break as the backfilled soil around the tank settles. A cast iron pipe sleeve or other suitable device can be slipped over the plastic pipe extending from the tank to unexcavated soil to provide this protection.

8.3.6 Operation and Maintenance

Little routine maintenance of dosing chambers is required. The tank should be inspected periodically, and any solids that accumulate on the floor of the tank should be removed. If pumps are used, the system should be cycled to observe operation of the switches and pump. If siphons are used, the water level in the tank should be noted over a period of time to determine if the siphon is operating properly. If the siphon is working properly, the water level will fluctuate from the bottom lip of the siphon bell to several inches above the bell. If the water elevation does not change despite water addition, the siphon is "dribbling," indicating that the vent tube on the bell requires cleaning.

8.4 Flow Diversion Methods for Alternating Beds

8.4.1 Description

Under some circumstances, it is desirable to divert the wastewater flow from one soil absorption area to another to provide long-term alternate resting periods (see Chapter 7). Flow diversion may be accomplished by the use of commercially available diversion valves (Figure 8-5) or by diversion boxes (Figures 8-6 and 8-7).

FIGURE 8-5
TYPICAL DIVERSION VALVE

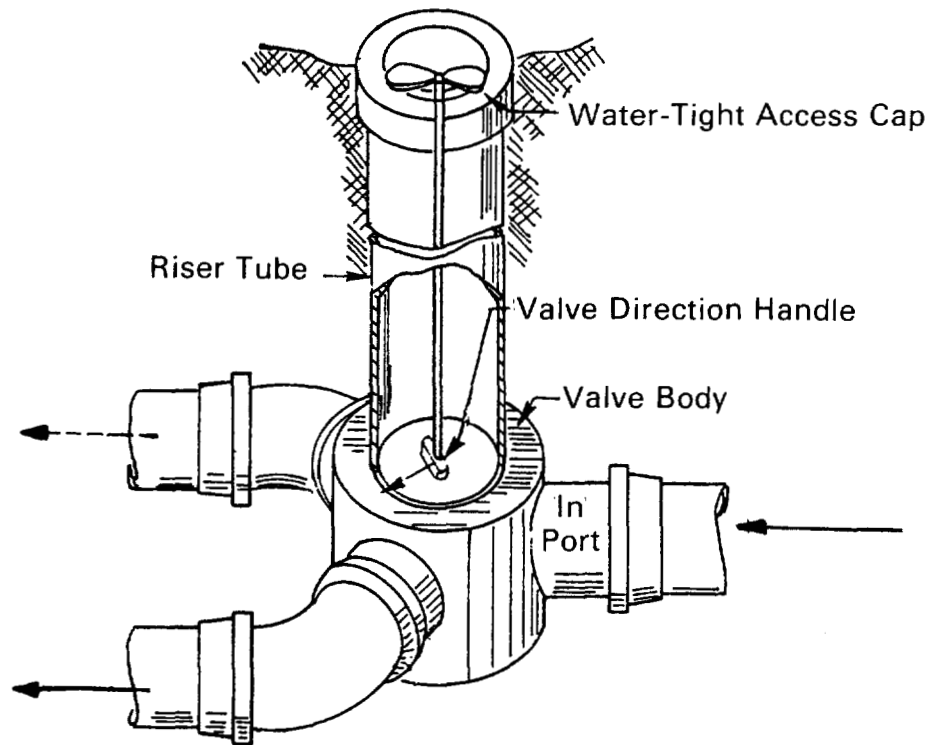

FIGURE 8-6

TOP VIEW OF DIVERSION BOX UTILIZING A TREATED WOOD GATE

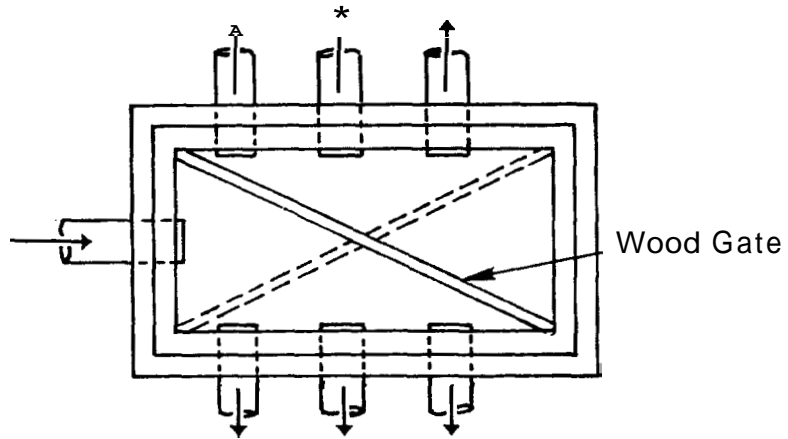
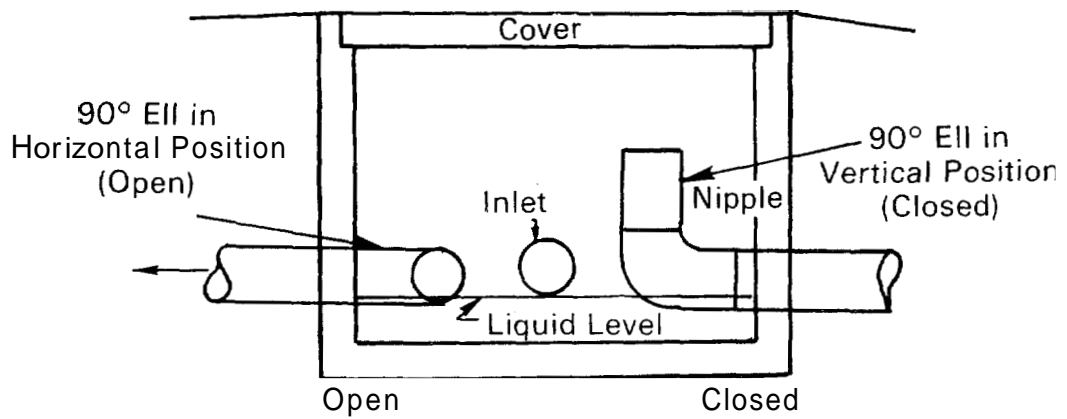

FIGURE 8-7

SECTION VIEW OF DIVERSION BOX UTILIZING ADJUSTABLE ELLS



8.4.2 Design

Diversion boxes can be made from conventional distribution boxes. One type of diversion box shown in Figure 8-6 uses a treated wood gate to divert the flow to the desired outlet pipe (5).

Another, shown in Figure 8-7, uses 90° ells that can be moved from the horizontal to the vertical position to shut off flow. Caps or plugs can be used in place of elbows. Elbows, however, provide a freer flow of air into the resting system. Insulated covers must be provided with diversion boxes when installed in cold climates.

8.4.3 Construction

Construction follows manufacturers recommendations or the procedures outlined for distribution boxes (Chapter 7).

8.4.4 Maintenance

Maintenance of diversion valves involves little more than turning the valve at the desired frequency. Any accumulated solids in the diversion box or valve should be removed periodically.

8.5 References

1. Manual of Septic Tank Practice. NTIS Report No. PB 216 240, Public Health Service, Washington, D.C., 1967. 92 pp.
2. Hogan, J. R. Grease Trap Discussion. Plumb Eng., May-June 1975.
3. HYGI Design Manual. M. C. Nottingham Company, Pasadena, California, 1979.
4. Converse, J. C. Design and Construction Manual for Wisconsin Mounds. Small Scale Waste Management Project, University of Wisconsin, Madison, 1978. 80 p.
5. Machmeier, R. E. Home Sewage Treatment Workbook. Agricultural Extension Service, University of Minnesota, St. Paul, 1979.

CHAPTER 9

RESIDUALS DISPOSAL

9.1 Introduction

Proper maintenance of onsite treatment systems requires periodic disposal of residual solids, sludges, or brines. In some areas, finding environmentally sound techniques for disposal of these residuals has been very difficult. Because of the possible presence of pathogens in many of these wastewaters, proper handling and disposal are important from a public health perspective. The homeowner's role in residuals handling is to ensure that residuals from his system are removed periodically at the appropriate interval so that proper system performance is maintained.

This chapter discusses the characteristics of residuals, and describes treatment and disposal options for septage (septic tank pumpings). The chapter is intended to be merely an overview of residuals handling options. The reader is referred to publications that discuss particular alternatives in greater detail.

9.2 Residuals Characteristics

Table 9-1 summarizes the residuals that may be generated by onsite wastewater handling systems. Typical characteristics, removal frequencies, and disposal modes are presented. Many of the residuals listed may contain significant amounts of pathogenic organisms, nutrients, and oxygen-demanding materials; thus, they require proper handling and disposal to protect public health and to prevent degradation of groundwater and surface water quality.

In general, residuals generated by onsite wastewater systems are highly variable in character. This is due to several factors, including type and number of fixtures, number and age of occupants, type of wastewater treatment system, and user habits.

The wastewater removed from septic tanks, commonly referred to as septage, is the most common residual generated from onsite wastewater systems. The characteristics of septage are presented in Tables 9-2 and 9-3. While information on septage characteristics and treatment/disposal alternatives is relatively abundant, data on other residuals listed in Table 9-1 are limited.

TABLE 9-1

RESIDUALS GENERATED FROM ONSITE WASTEWATER SYSTEMS (1)

<u>Residual</u>	<u>Source</u>	<u>Frequency of Removal</u>	<u>Characteristics</u>	<u>Disposal^a</u>
Septage	Septic tank	2 to 5 yr	High BOD and SS; odor, grease, grit, hair, pathogens	Pump out by professional hauler for off-site disposal .
Sludge	Aerobic unit	1 yr	High BOD and SS; grease, hair, grit, pathogens	Pump out by professional hauler for off-site disposal .
Sewage	Holding tank	week to months	Strong septic sewage; odor, pathogens	Pump out by professional hauler for off-site disposal .
Blackwater	Holding tank	6 months-1 yr	High BOD and SS; odor, pathogens	Pump out by professional hauler for off-site disposal .
Recycle Residuals	Recycle systems	6 months-1 yr	Variable depending on unit processes employed	Pump out by profesisonal hauler for off-site disposal .
Compost	Compost toilet; large small	6 months-1 yr 3 months	Relatively stable, high organics, low pathogens	Homeowner performs onsite disposal; garden burial.
Ash	Incinerator toilet	weekly	Dry, sterile, low volume	Onsite burial by homeowner or disposal with rubbish to landfill
Scum	Sand filters	6 months	Odor, pathogens, low volume	Onsite burial by homeowner or off-site disposal

^a Approval by state or local regulatory agency necessary.

TABLE 9-2
CHARACTERISTICS OF DOMESTIC SEPTAGE

<u>Parameter</u>	<u>Mean Value</u> <u>mg/l</u>	<u>Reference</u>
Total Solids	22,400	2
	11,600	3
	39,500	4
Total Volatile Solids	15,180	2
	8,170	3
	27,600	4
Suspended Solids	2,350	2
	9,500	3
	21,120	5
	13,060	6
Volatile Suspended Solids	1,770	2
	7,650	3
	12,600	5
	8,600	6
BOD	4,790	2
	5,890	3
	3,150	6
COD	26,160	2
	19,500	3
	60,580	4
	24,940	5
	16,268	6
pH	6-7 (typical)	2,3,4
Alkalinity (CaCO ₃)	610	3
	1,897	5
TKN	410	3
	650	4
	820	5
	472	6
NH ₃ -N	59	2
	100	3
	120	4
	92	5
	153	6

TABLE 9-2 (continued)

<u>Parameter</u>	<u>Mean Value</u> mg/l	<u>Reference</u>
Total Phosphorus	190	3
	214	4
	172	5
	351	6
Grease	3,850	3
	9,560	4
Aluminum	48	6
Arsenic	0.16	6
Cadmium	0.1	3
	0.2	4
	9.1	6
Chromium	0.6	3
	1.1	6
Copper	8.7	3
	8.3	6
Iron	210	3
	160	4
	190	6
Mercury	0.02	4
	0.4	6
Manganese	5.4	4
	4.8	6
Nickel	0.4	3
	<1.0	4
	0.7	6
Lead	2.0	3
	8.4	6
Selenium	0.07	6
Zinc	9.7	3
	62	4
	30	6

TABLE 9-3
INDICATOR ORGANISM AND PATHOGEN CONCENTRATIONS
IN DOMESTIC SEPTAGE

<u>Parameter</u>	<u>Typical Range</u> counts/100 ml	<u>Reference</u>
Total Coliform	$10^7 - 10^9$	5
Fecal Coliform	$10^6 - 10^8$	4,5,7
Fecal Streptococci	$10^6 - 10^7$	4,5,7
Ps. aeruginosa	$10^1 - 10^3$	4,5,7
Salmonella sp.	$<1 - 10^2$	4,5
Parasites		
Toxacara, Ascaris lumbricoides, Trichuris trichiura, Trichuris vulpis	Present	5

Septage, a mixture of sludge, fatty materials, and wastewater removed during the pumping of a septic tank, is a difficult and undesirable material to handle. It is often highly odoriferous and may contain significant quantities of grit, grease, and hair that may make pumping, screening, or settling difficult. Of particular importance is the high degree of variability of this material, some parameters differing by two or more orders of magnitude. This is reflected to some extent by the variability in mean values presented in Table 9-2. For this reason, septage should be characterized prior to selection of design values.

In general, the heavy metal content of septage is low relative to municipal wastewater sludge, although the range of values may be wide. Because of the low metal content, application rates may be based on nitrogen rather than metal loading for land application systems (8).

Table 9-3 presents typical concentration ranges for indicator organisms and pathogens in septage. These values are not unlike those found for raw primary wastewater sludge. It is evident that septage may harbor disease-causing organisms, thus demanding proper management to protect public health.

Accumulation rates of residuals differ for the same reasons that account for their variability in characteristics: that is, type and number of fixtures, occupancy characteristics, type of wastewater system, user habits, etc. The figures presented in Table 9-1 for frequency of residuals removal reflect typical ranges found in practice, although the range of actual values may be greater.

9.3 Residuals Handling Options

Residuals that potentially may be disposed of onsite by the homeowner include compost from compost toilets, ash from incinerating toilets, and the solids mat from sand filters. Assuming proper operation of the unit, ash from incinerating toilets is sterile and can be safely disposed of by mixing it with soil on the homeowner's property, or by handling with household solid wastes. Residuals from compost toilets are relatively stable, but may contain pathogenic bacteria and virus, especially if the system has not been properly operated and maintained. Onsite burial is approved in some states but not in others, due to the possible health hazards of handling the waste. The same conditions hold for disposal of the scum that must be periodically raked off filtration units.

Pathogens may be present in the scum layer, and approval for onsite disposal varies with locale. The appropriate state or local regulatory agency should be consulted for the requirements in a particular area.

As Table 9-1 indicates, the residues from septic tanks, aerobic treatment units, holding tanks, and recirculating toilets must be periodically pumped out and disposed of by professional haulers. The homeowner's responsibility should be to ensure that this service is provided before residuals buildup impairs performance of the treatment unit.

9.4 Ultimate Disposal of Septage

By far the most common waste material generated from onsite systems is septage. The following discussion provides a brief overview of techniques for disposal of this waste. For a more complete description of these processes, the reader is referred to the list of references at the end of this chapter.

There are three basic methods for disposing of septage: disposal to land, treatment and disposal at separate septage handling facilities, and treatment at existing wastewater treatment plants.

9.4.1 Land Disposal

Four methods can be used for disposing of septage to land: surface spreading, subsurface disposal, trenching, and landfilling. Table 9-4 summarizes the main characteristics of these disposal techniques.

Land spreading is the most frequently used septage disposal method in the United States. Surface spreading of septage is generally accomplished by the same techniques as municipal liquid wastewater sludge spreading. This may simply involve the septage pumping truck emptying its contents on the field while slowly driving across the site. This technique has very low operation and maintenance requirements. A more controlled approach is to use a holding tank to receive septage loads when the soil is not suitable for spreading. A special vehicle (tractor or truck with flotation tires) can then be used to spread the septage when weather and soil conditions permit.

Subsurface disposal techniques have gained wide acceptance as alternatives for disposal of liquid sludge and, to some extent, septage. Three basic approaches to subsurface disposal are available:

1. Incorporation using a farm tractor and tank trailer with attached subsurface injection equipment.
2. Incorporation using a single, commercially available tank truck with subsurface injection equipment.
3. Incorporation using tractor-mounted subsurface injection equipment in conjunction with a central holding facility and flexible "umbilical cord." Liquid sludge is continually pumped from the holding tank to the injection equipment.

Disposal of septage by burial in excavated trenches is another common disposal technique. Trenches are typically 3 to 6 ft (0.9 to 1.8 m) deep and 2 to 3 ft (0.6 to 0.9 m) wide, with dimensions varying with site location. Space between trenches should be sufficient to allow movement of heavy equipment. A series of trenches is usually dug by a backhoe to allow sequential loading and maximum dewatering. Septage is usually applied in 6- to 8-in. (15 to 20 cm) layers. When the trenches are full, the solids can be excavated and placed in a landfill if they have dewatered sufficiently, or the trenches can be covered with 2 ft (0.6 m) of soil. A thorough site evaluation is essential to prevent groundwater contamination with this disposal technique.

TABLE 9-4

LAND DISPOSAL ALTERNATIVES FOR SEPTAGE

<u>Alternative</u>	<u>Design Considerations</u>	<u>Advantages</u>	<u>Disadvantages</u>
Subsurface Disposal (1)(2)(8) (9)(17) (19)	Septage volume/characteristics Climate Site characteristics - Soil type/permeability - Depth to groundwater or bedrock - Aquifer size, flow characteristics, use - Slope - Proximity to dwellings, etc. - Crop and crop use - Size of site - Site protection Equipment selection Application rate Winter storage or contingency plan Monitoring wells	Low human contact potential Low incidence of odors and vectors Aesthetically more acceptable than surface spreading Good soil amendment	Large land requirements Storage may be required during inclement weather - wet or frozen ground Need more equipment than for surface spreading
Surface Spreading (1)(2)(8) (9)(17) (19)	Septage volume/characteristics Application rate (N loading) Climate Storage facilities Site characteristics (same as subsurface disposal) Equipment selection Monitoring wells	Small labor requirement Minimum equipment required Benefit from fertilizer - Soil amendment value Low cost Simple Operation	Possible odor and aesthetic nuisance Spreading restricted by wet or frozen soil Storage may be required during inclement weather Pretreatment may be required for deodorization and pathogen destruction Possible human contact or vector attraction

TABLE 9-4 (continued)

<u>Alternative</u>	<u>Design Considerations</u>	<u>Advantages</u>	<u>Disadvantages</u>
Trench Disposal (1)(9)(17) (18)	Septage volume/characteristics Site characteristics - Soil type/permeability - Depth to groundwater or bedrock - Aquifer size, flow characteristics, use - Proximity to dwellings, etc. - Proximity to septage sources Site protection Equipment selection Design life Monitoring wells	Simple operation Low labor requirement Minimal equipment required Low cost Less land required than surface or subsurface spreading operations	Higher potential for groundwater contamination Odors and vectors Limited design life - usually cannot use same land repeatedly
Sanitary Landfill Disposal (1)(9)(14)	Septage/refuge ratio Leachate collection/treatment Monitoring wells	No new equipment needed Low odor and pathogen problems due to daily soil cover Low cost	Limited application due to leachate generation Good operating procedures required - refuse/septage mixing Extensive monitoring required - leachate, runoff, groundwater May not be approved in some states

Sanitary landfills in the United States generally accept a multiplicity of materials such as refuse, industrial wastes, and sometimes hazardous or toxic wastes. All of these wastes are compiled on a daily basis at the landfill and buried under a soil cover. The acceptance of septage at a landfill depends chiefly on the ratio of the mixture of septage to refuse to maintain moisture control. However, a few states do not allow landfill disposal of septage, and some others do not recommend it because of potential runoff and leachate problems.

9.4.2 Independent Septage Treatment Facilities

In some areas of the country, facilities have been constructed exclusively for handling septage. These systems vary from simple holding lagoons to sophisticated, mechanically based plants. The latter systems are generally more capital intensive, and may also have greater operational requirements. Such systems have been found to be cost effective in areas of significant septic system density, such as Long Island, New York. In rural areas, simpler, less expensive alternatives may be more economically favorable. Of the independent facilities listed in Table 9-5, lagoons are the most common and among the least expensive independent septage handling alternatives. All of the other independent systems have been implemented to some degree, although in most cases, not widely.

9.4.3 Septage Handling at Wastewater Treatment Plants

Two methods exist for handling septage at wastewater treatment facilities: addition to the liquid stream (near the headworks or upstream from the plant), or addition to the solids handling train (see Table 9-6). Both have advantages under appropriate conditions. For example, addition to the headworks (screens, grit chamber) is desirable where the plant employs primary clarification, since this effectively introduces the septage solids directly into the sludge handling scheme. For extended aeration plants, however, septage addition to the wastewater flow may have a severe impact on the aeration capacity of the system. Thus, introducing the septage into the sludge stream may be desirable. Consideration of plant aeration and solids handling capacity is necessary to determine whether either scheme is feasible. Under either mode of addition, solids production increases with increased septage addition. Septage holding facilities allow controlled addition of the septage to the wastewater treatment plant.

For additional information on the capability of wastewater treatment facilities to handle septic tank pumpings, the reader is referred to the publications list in Section 9.5 (3)(11).

TABLE 9-5

INDEPENDENT SEPTAGE TREATMENT FACILITIES

<u>Process</u>	<u>Description</u>	<u>Design Considerations</u>	<u>Advantages</u>	<u>Disadvantages</u>
Lagooning (1)(13)(14) (16)(17)	Usually anaerobic or facultative Inlet on bottom for odor control Liquid disposal by percolation and evaporation in lagoon or by separate infiltration bed pH adjustment to pH 6-8 may be necessary for odor control	Septage volume/characteristics Site location - Distance to dwellings, etc. - Depth to groundwater or bedrock - Distance to surface water Depth of liquid, surface area Climate Aquifer characteristics Monitoring wells Solids removal and disposal	Low cost Simple operation	Odor problems if pH not maintained Cannot use in areas with high water table Possible vector problem Soil clogging may stop percolation
Lime Stabilization (1)(4)(5)	Collection, mixing, and reaction with lime to pH 12 (hold 1 hour) Dewatering optional Odors eliminated, pathogens greatly reduced	Septage volume/characteristics Septage receiving/holding Mixing (air or mechanical) Lime handling and feeding Final disposal	Odor eliminated Good pathogen reduction Low land requirement Enhanced solids dewatering	No reduction in organic matter Lime increases quantity for final disposal High cost for labor and lime Unknown effects of long-term storage
Chlorine Oxidation (1)(9)(15)	Chlorine and septage mixed in pressurized reaction chamber pH 1.2 - 2.5 Chlorine dosage 700-3,000 mg/l	Septage volume/characteristics Equipment sizing Septage receiving/holding Dewatering facilities Final solids disposal Chlorine storage/safety	Stable, odor-free sludge produced High pathogen destruction Enhanced solids dewatering Low land requirement	High operating costs dependent on chlorine cost Neutralization may be required Question of harmful chlorinated organics Underdrainage liquor requires further treatment
Aerobic Digestion (1)(9)(13)	Similar to aerobic digestion of sewage sludge Often accomplished at existing wastewater treatment plant	Septage volume/characteristics Septage receiving/holding Organic loading Solids retention time (20-30 days) Climate (temperature) Mixing and DO level Final disposal	SS reduction BOD reduction Reduction of Odor and pathogens May enhance solids dewatering Low land requirement	Biological operation not simple Subject to organic overloading Requires monitoring and lab analysis Can have foaming problems

TABLE 9-5 (continued)

<u>Process</u>	<u>Description</u>	<u>Design Considerations</u>	<u>Advantages</u>	<u>Disadvantages</u>
Composting (1)	May be natural draft or forced air Septage mixed with bulking material High temperature/pathogen destruction Storage/distribution	Septage volume/characteristics Septage receiving/holding Bulking agent availability Dewatering Materials handling capability	Provides pathogen destruction and stabilization Produces soil amendment Operationally simple Low energy requirements	High bulking agent requirement if not dewatered Product market must be established May be labor-intensive
Anaerobic Digestion (9)(11)	Often accomplished in combination with sewage sludge Demonstrated on pilot-scale Identical to sludge digestion technology	Septage volume/characteristics Septage receiving/holding Grit removal Solids retention time Maintenance of digester temperature No toxic materials input Final disposal	Methane recovery/ utilization possible Stabilized product Can handle variety of organic wastes	Biological process requires close operator control Subject to upset by toxics Requires continuous supply of organic materials
Chemical Treatment (1)(9)(10)	Chemical coagulation - Mixing and settling - Supernatant collection, treatment/disposal - Sludge holding/dewatering/disposal Acidification (H ₂ SO ₄) - Mixing and settling - Additional coagulation possible with lime	Septage volume/characteristics Septage receiving/holding Chemical feed equipment and dose levels Mixing, reaction time, settling time Final disposal	Low land requirement	High labor requirement High costs
Dewatering (1)(10)	Drying beds Pressure filtration Vacuum filtration Drying lagoons Centrifugation	Septage volume/characteristics Septage receiving/holding SS concentrations Filterability Pretreatment-chemical conditioning Final disposal	Reduced hauling costs Reduces area required for disposal	High cost for some alternatives High operation and maintenance requirements Mechanical dewatering devices require an enclosure

TABLE 9-6

SEPTAGE TREATMENT AT WASTEWATER TREATMENT PLANTS

<u>Process</u>	<u>Description</u>	<u>Design Considerations</u>	<u>Advantages</u>	<u>Disadvantages</u>
Liquid Stream Addition (3)(6)(11)(12)	Septage placed in storage tank at plant Pretreatment (screening, grit removal) Controlled bleed into headworks to prevent shock overload	Septage volume/characteristics Plant capacity (aeration and solids handling) Receiving station - Truck transfer - Storage - Pretreatment (optional) - Controlled discharge to plant Sludge production O&M (power, labor, chemicals)	Easily implemented Low capital cost Public acceptance good Particularly desirable at plants with primary clarification	Additional sludge generation May organically overload plant Increased O&M Final disposal site and sludge equipment expansion may be needed
Sludge Stream Addition (6)(11)(12)	Septage placed in storage tank Fed directly into sludge stream with or without separate conditioning/handling	Septage volume/characteristics Septage receiving/holding Organic and solids loading on each sludge handling unit Pumping and storage capacity Additional mixing and feeding equipment Increase in chemical usage	Avoids overloading secondary and tertiary systems Avoids possibility of final effluent degradation	Additional sludge generation Final disposal site and sludge equipment expansion may be needed

9.5 References

1. Bowker, R. P. G., and S. W. Hathaway. Alternatives for the Treatment and Disposal of Residuals from On-Site Wastewater Systems. Municipal Environmental Research Laboratory, Cincinnati, Ohio, 1978.
2. Kolega, I. J., A. W. Dewey, B. J. Cosenza, and R. L. Leonard. Treatment and Disposal of Wastes Pumped from Septic Tanks. EPA 600/2-77-198, NTIS Report No. PB 272 656, Storrs Agricultural Experiment Station, Connecticut, 1977. 170 pp.
3. Segall, B. A., C. R. Ott, and W. B. Moeller. Monitoring Septage Addition to Wastewater Treatment Plants, Volume I: Addition to the Liquid Stream. EPA 600/2-79-132, NTIS Report No. PB 80-143613, 1979.
4. Feige, W. A., E. T. Oppelt, and J. F. Kreissl. An Alternative Septage Treatment Method: Lime Stabilization/Sand-Bed Dewatering. EPA 600/2-75-036, NTIS Report No. PB 245 816, Municipal Environmental Research Laboratory, Cincinnati, Ohio, 1975. 64 pp.
5. Noland, R. F., J. D. Edwards, and M. Kipp. Full Scale Demonstration of Lime Stabilization. EPA 600/2-78-171, NTIS Report No. PB 286 937, Burgess and Niple Ltd., Columbus, Ohio, 1978. 89 pp.
6. Bennett, S. M., J. A. Heidman, and J. F. Kreissl. Feasibility of Treating Septic Tank Waste by Activated Sludge. EPA 600/2-77-141, NTIS Report No. PB 272 105, District of Columbia, Department of Environmental Services, Washington, D.C. , 1977. 71 pp.
7. Deninger, J. F. Chemical Disinfection Studies of Septic Tank Sludge with Emphasis on Formaldehyde and Glutaraldehyde. M.S. Thesis. University of Wisconsin, Madison, 1977.
8. Maine Guidelines for Septic Tank Sludge Disposal on the Land. Miscellaneous Report 155. Life Sciences and Agriculture Experiment Station and Cooperative Extension Service, University of Maine, Orono, Maine Solid and Water Conservation Commission, 1974.
9. Cooper, I. A., and J. W. Rezek. Septage Treatment and Disposal. Prepared for the EPA Technology Transfer Seminar Program on Small Wastewater Treatment Systems, 1977. 43 pp.
10. Condren, A. J. Pilot Scale Evaluations of Septage Treatment Alternatives. EPA 600/2-78-164, NTIS Report No. PB 288 415, Maine Municipal Association, Augusta, Maine, 1978. 135 pp.

11. Bowker, R. P. G. Treatment and Disposal of Septic Tank Sludges. A Status Report. May 1977. In: Small Wastewater Treatment Facilities. Design Seminar Handout. Environmental Protection Agency Technology Transfer, Cincinnati, Ohio, 1978.
12. Cooper, I. A., and J. W. Rerek. Septage Disposal in Wastewater Treatment Plants. In: Individual On-Site Wastewater Systems. Proceedings of the Third National Conference. N. McClelland, ed. Ann Arbor Science, Ann Arbor, Michigan, 1977. pp. 147-169.
13. Jewell, J. W., J. B. Howley, and D. R. Perrin, Design Guidelines for Septic Tank Sludge Treatment and Disposal. Prog. Water Technol., 7, 1975.
14. Guidelines for Septage Handling and Disposal. New England Interstate Water Pollution Control Commission, Boston, Massachusetts, August 1976.
15. Wise, R. H., T. A. Pressley, and B. M. Austern. Partial Characterization of Chlorinated Organics in Superchlorinated Septages and Mixed Sludges. EPA 600/2-78-020, NTIS Report No. PB 281 529, USEPA, MERL, Cincinnati, Ohio, 1978. 30 pp.
16. Brown, D. V., and R. K. White. Septage Disposal Alternatives for Rural Areas. Research Bulletin 1096, Ohio State University, Columbus, 1977.
17. Barlow, Gill and E. Allan Cassell. Technical Alternatives for Septage Treatment and Disposal in Vermont. Draft. Vermont Water Resources Research Center, University of Vermont, Burlington, 1978.
18. Walker, J. M., W. D. Burge, R. L. Chaney, E. Epstein, and J. D. Menzies. Trench Incorporation of Sewage Sludge in Marginal Agricultural Land. EPA 600/2-75-034, NTIS Report No. PB 246 561, Agricultural Research Service, Beltsville, Maryland, 1975. 252 pp.
19. Sommers, L. E., R. C. Fehrmann, H. L. Selznick, and C. E. Pound. Principles and Design Criteria for Sewage Sludge Application on Land. In: Sludge Treatment and Disposal Seminar Handout, Environmental Research Information Center, Cincinnati, Ohio, 1978.

CHAPTER 10

MANAGEMENT OF ONSITE SYSTEMS

10.1 Introduction

Onsite systems offer a viable means for controlling public health hazards, environmental degradation, and nuisances that might otherwise arise from wastewater generated in unsewered areas. If onsite systems are to perform successfully over a reasonable lifetime, a sound management program with sufficient technical assistance and enforcement capabilities is needed.

Management programs may take many forms. A good program, at a minimum, performs the following functions:

1. Site evaluation validation
2. System design review
3. Construction supervision
4. Operation and maintenance certification
5. Rehabilitation assistance
6. Monitoring and enforcement
7. Public education activities

Most states perform some or all of these functions with much of the responsibility often delegated to local units of government. These programs are very diverse (1). At one end of the spectrum, the state may limit its responsibility to the promulgation of minimum standards to be adopted by local jurisdictions, which may have the right to establish stricter standards. At the other end, the state may retain all management functions over onsite systems.

Thus, the management programs used in various jurisdictions differ greatly as do their effectiveness. Therefore, the following examination of approaches and techniques that may be used to manage onsite systems is intended to:

1. Provide a means of evaluating the existing management program.
2. Suggest techniques used to improve an existing management program or to establish a new one.

Some of the techniques discussed may not be readily incorporated into existing management programs due to different state constitutional and statutory provisions and legal interpretations. Some techniques may require the enactment of enabling legislation granting the management entity necessary authority to manage onsite systems.

10.2 Theory of Management

An effective management program provides technical assistance together with strong regulation enforcement. Both aspects are directed at major control points.

10.2.1 Principal Control Points

There are several distinct phases in the life of an onsite system that require control. These are:

1. Installation
2. Operation
3. Maintenance

During the "installation" phase, the management program must limit installation to suitable sites, and assure the proper design and construction of all onsite systems. It is during this phase that management programs can be most effective in minimizing the potential threat to public health and water quality.

During the "operation" phase, the management program must assure proper operation of an onsite system through periodic monitoring. While there are very few operational requirements for a septic tank-soil absorption system, some of the onsite systems have more extensive requirements. A good management program imposes controls during this phase whether the system's operation is straightforward or elaborate.

Finally, in the "maintenance" phase, the management program must provide for adequate maintenance of an onsite system, e.g., periodic pumping of septic tanks. It also must detect any onsite system that fails to function properly. This may be done through systematic or random inspections. A good program takes the necessary action to assure that repair, replacement, or abandonment of failed systems is completed.

10.2.2 Authority Needed by Management Entities

If adequate management is to be provided at the principal control points, management entities should have the authority to perform the functions listed below. The optional functions become imperative if the management entities own the onsite systems.

Suggested Functions

1. Site evaluation
2. System design
3. Installation
4. Operation and Maintenance
5. Rehabilitation
6. Monitoring

Optional Functions

1. Planning
2. Legal functions
3. Financing
4. Public education

The authority to perform these functions does not need to be granted to a single management entity. In fact, it is unlikely that one entity will have all the program responsibility. However, the total management program should have the combined authority to perform the necessary functions.

In each jurisdiction, the authority of each management entity should be examined. Statutory authority, judicial decisions, and the state constitution must be carefully reviewed. Often existing programs may be adapted and/or utilized to aid in management. For example, the management entities may require that certain onsite systems be designed by registered professional engineers even though the entities themselves do not register engineers. In the event that additional authority is needed, enabling statutory language will be required.

10.3 Types of Management Entities

There are several types of entities that have the authority to perform the management functions previously described. These include:

1. State agencies
2. Local governmental/quasi-governmental units
3. Special purpose districts
4. Private institutions (profit, nonprofit)

10.3.1 State Agencies

Except for the limitations contained in its own constitution, each state retains complete authority to protect the general welfare of its citizens, including the management of onsite systems. The state health agency and/or agency responsible for water quality are the agencies most likely to exercise the state's authority.

The degree of control exerted by state agencies over onsite systems varies from state to state. Many states set design standards for onsite systems. Those that do not set standards delegate authority to local governments to do so. Several states retain the responsibility for administrative/technical portions of the onsite management program.

A state management program is often considered more effective, because local pressures to weaken onsite regulation are not thought to be as effective at the state level. In addition, since states typically have more resources to hire or retain experienced individuals than most local units of government, state agencies are in a better position to take responsibility for many of the regulatory and administrative requirements.

10.3.2 Local Governmental/Quasi-Governmental Units

In some states, a portion or most of the responsibility of onsite system management is delegated by the legislature to units of local government. In other states with strong "home rule" powers, the local unit of government has the authority to manage onsite systems even without being so delegated by the state legislature. The various types of local governmental units are:

1. Municipalities - Incorporated units of government have full responsibility for the general welfare of its citizens; have broad financing authority, including the authority to levy property taxes, to incur general obligation debts, to use revenue bonding and to impose special assessments upon benefited property; and are legal entities authorized to contract, commence law suits, and own property.
2. Unincorporated Government (e.g., County) - Unincorporated governmental units often have authority equal to municipalities; however, these units may not have the authority for some onsite program management responsibilities, i.e., ownership of onsite systems which do not serve county institutions. Typically,

these units have financial authority and legal entity status similar to municipalities.

3. Quasi-Governmental Units - These units include regional (multi-county) water quality boards, regional planning commissions, local or regional health departments/boards, councils of government, and other agencies with the exception of special purpose entities. Their authority varies with the intended purpose of each unit; however, the financial authority is typically less than that of municipalities and unincorporated governmental units.

10.3.3 Special Purpose Districts

Special purpose districts depend entirely on enabling legislation for their authority and extent of services. These districts are independent units of government, created to provide one or more services, such as water and wastewater services to those within their boundaries. If permitted by the enabling legislation, services may also be provided to others outside their boundaries. The boundaries are often permitted to cross local governmental boundaries so that services can be provided to all those in need, despite the fact that residents of the district reside on either side of local governmental boundaries (counties, towns, villages, etc.).

Nearly all special purpose districts have sufficient financial authority to impose service charges, collect fees, impose special assessments upon property benefitted, and issue revenue and/or special assessment bonds. In addition, some special purpose districts receive the same financing authority enjoyed by municipalities, including the authority to levy taxes and incur general obligation debt (i.e., general obligation bonds backed by taxing authority). These districts are usually legal entities that may enter into contracts, sue, and be sued.

10.3.4 Private Institutions

Private institutions do not rely on enabling legislation, but are founded upon the right of individuals or corporations to enter into contracts. However, they are often subject to review or regulation by state public service or utility commissions.

10.3.4.1 Private Nonprofit Institutions (Associations and Corporations)

These entities include homeowners' associations, private cooperatives, and nonprofit corporations that provide services for onsite systems. The range of services may vary from merely providing maintenance to complete ownership of the system. The freedom of the contract permits this complete range of services; however, the association or corporation may be regulated by the state public service or public utility laws.

10.3.4.2 Private-for-Profit Institutions

This type of entity may be a sole proprietorship, partnership, or corporation that provides services for onsite systems. The homeowner or a group of owners (homeowners' associations) typically enters into a contract with this private entity for the provision of services. These services could include maintenance and operation of the owner's onsite system, or the private entity could own the systems and charge the homeowner for the use of the systems. The state public service or public utility commission may regulate the private entity.

10.4 Management Program Functions

A good management program consists of many functions that may be performed by one entity only or shared among several entities. The user of this manual is urged to review the range of functions discussed here, and to select entities that are best able to perform those functions. For a more complete discussion of the various functions, see References (2) and (3).

10.4.1 Site Evaluation and System Design

In developing a management program, a choice can be made between performing the site evaluation and system design functions within the entity itself or reviewing work done in the private sector. Table 10-1 summarizes the suggested activities that should be performed for both options.

TABLE 10-1
SITE EVALUATION AND SYSTEM DESIGN FUNCTIONS

<u>Scope of Activities</u>	<u>Administrative/Technical Activities</u>	<u>Regulatory/Enforcement Activities</u>
<u>Perform</u> all site evaluations and provide system designs	<ul style="list-style-type: none"> a. Conduct site evaluations for each lot to be developed b. Identify and evaluate feasible (or permitted) system designs c. Design selected system 	<ul style="list-style-type: none"> a. Establish guidelines and procedures for identifying sites suitable for development b. Develop cost-effective-ness guidelines and evaluation procedures c. Establish design standards, construction specifications, and performance standards and Issue construction permit
Review all site evaluations and system designs	<ul style="list-style-type: none"> a. Verify site evaluation procedures and data collected for each lot b. Review and approve or disapprove plans 	<ul style="list-style-type: none"> a. Develop guidelines and procedures for identifying sites suitable for development and Develop training, certification, or licensing program for site evaluators b. Establish design standards, construction specifications, and performance standards and/or Develop training certification or licensing program for system designers and Issue construction permit

10.4.1.1 Standards for Site Suitability, System Design, and Performance

A state agency with appropriate authority may establish minimum standards for site suitability, system design, and performance. This may be preferred over each management entity establishing its own standards. The advantages are (1) more uniformity of regulations throughout the state (although the local management entity may choose to be more stringent if it has the power to do so), and (2) more resources and experienced personnel at the state level to develop appropriate standards.

10.4.1.2 Site Evaluation and System Design

It may be desirable to include site evaluation and system design activities as part of the management program. These activities could be performed by any of the entities making up the management program. However, if the local management entity proposes to own and operate systems within its jurisdiction, this would be the preferred entity to perform these activities. Legal advice should be sought regarding liability which may result from undertaking this activity.

As an alternative to performing site evaluations and system designs as part of the management program, these activities could be performed by site evaluators and system designers licensed or registered by the management entity. Licensure or registration is suggested to assure quality. However, such assurances can only be obtained if the license or registration is subject to suspension or revocation. Random or preapproved site inspections by the management entity are suggested to check compliance with established procedures and standards, particularly where site limitations are anticipated.

10.4.1.3 Plan Approval and Construction Permits

The management process should be initiated either by submission of plans for review and approval or by application for a permit to construct a system. Either requirement for plan approval or permit issuance for construction of a system provides the management entity with a convenient method of obtaining information about the site evaluation and system design. Site suitability and design standards may be easily enforced by refusing to approve plans or issue permits.

Plan approval or permit programs at the state level may be more desirable than at the local level because of greater technical resources and isolation from local political pressures to allow development on poorly

sited sites. As an alternative to the review of all applications, the state agency could review a random sample of the plans approved or permits issued by the local management entity. The state agency would have the authority to countermand local approval. However, it would be necessary to limit the period of time that the state agency has to act on the local action.

10.4.2 Installation

As with site evaluation and system design, the management entities could choose to install all new systems themselves. This would be particularly desirable if ownership were to be retained by the entity. If not, the entity may choose to control installation through inspections. Table 10-2 summarizes the suggested activities that should be performed for both options.

10.4.2.1 Construction Inspections

A program to inspect the onsite system at each critical stage during construction is very desirable to prevent improper construction and premature failure of the system. The inspection may be performed by any entity involved in the total management program, but it would be most appropriate for the entity that has responsibility for the rehabilitation or abandonment of improperly functioning systems.

If the management entity does not perform the inspections, they could be performed by licensed or registered inspectors. A state agency would be the most likely entity to develop a program to train inspectors in proper design and construction techniques for all acceptable types of systems. This would assure more uniform quality of inspections statewide.

To further assure uniformity and thoroughness of inspections, checklists of specific items to be inspected for each type of permitted design could be developed. The inspectors would be required to certify that the checklist was completed after the inspector's personal inspection of the installation, and that all entries contained on the checklist are correct. To insure that inspections are timely, the management entity may require the system installer to give notice as to when the construction of the system is to commence.

TABLE 10-2
INSTALLATION FUNCTIONS

<u>Scope of Activities</u>	<u>Administrative/Technical Activities</u>	<u>Regulatory/Enforcement Activities</u>
<u>Perform</u> inspection/supervision of construction	a. Perform construction inspection and/or supervision during various phases of construction	a. Develop guidelines and specifications for construction
	b. Prepare as-built drawing	b. Record as-built drawing and issue system use permit
<u>Review</u> construction inspection/supervision	a. Review certified inspection by licensed/registered inspectors	a. Develop specifications for construction and checklists for inspection and Develop training, certification or licensing program for inspectors
	b. Require as-built drawing	b. Record as-built drawing and issue system use permit

10.4.2.2 As-Built Drawings

It is not unusual for the system installed to be quite different from the drawings originally approved because of changes necessary during construction. As-built drawings become very valuable when inspection or servicing of the system is required. Therefore, a requirement for as-built drawings is a good practice. These plans could be indexed by street, address, name of original owner, installer, and legal description.

10.4.2.3 Training and Licensing of Installers

To reduce the reliance on good construction supervision and inspections, a program to train and license or register installers could be established. Training would include presentation of design and construction techniques of all approved system types. To be effective, this program would have to be coupled with a strong enforcement program in which the license to install systems could be suspended or revoked.

10.4.3 Operation and Maintenance

Traditionally, the responsibility for operation and maintenance of on-site systems has been left to the owner. This has been less than satisfactory. As an alternative, management entities are beginning to assume this responsibility. The program adopted may either be compulsory or voluntary. If voluntary, the management entities perform the maintenance or issue operating permits on receipt of an assurance that the proper maintenance was performed. Table 10-3 summarizes the suggested activities that should be performed for both options.

10.4.3.1 Standards for Operation and Maintenance

A standard for the operation and maintenance of each type of system used, stating the procedures to be used and the frequency with which they are to be performed, is desirable. These standards would include those necessary to regulate the hauling and disposal of residuals generated by onsite systems as well. The state agency would be the preferred entity to set these standards. The advantages of having the state set the standards include more uniformity in the regulations and more resources and experienced personnel to develop appropriate standards.

10.4.3.2 Operating Permits

Rather than the management entities providing services, compliance with operation and maintenance standards could be assured through an operating permit program. The type and frequency of maintenance required for each type of system would be established by the entity. An operating permit allowing the owner to use the system would be renewed only if the required maintenance is performed. The system owner would be notified when the permit is about to expire, and told what maintenance must be performed to obtain a renewal. The owner would be required to have the necessary maintenance performed by an individual licensed or registered to perform such services within a specified period of time (e.g., 60 days). This individual would sign and date one portion of the owner's permit, thereby certifying that the service was performed.

The enabling ordinance or statutory language establishing this permit program must indicate that it is unlawful to occupy a home served by an onsite system unless the owner holds a valid operating permit. Thus, if the permit were not renewed, the owner would be in violation of the ordinance or statute. From a legal viewpoint, enforcement of this type of violation is straightforward.

TABLE 10-3
OPERATION AND MAINTENANCE FUNCTIONS

<u>Scope of Activities</u>	<u>Administrative/Technical Activities</u>	<u>Regulatory/Enforcement Activities</u>
<u>Perform</u> necessary operation/maintenance	<ul style="list-style-type: none"> a. Provide routine and emergency operation/maintenance of each system b. Determine if operation/maintenance program is voluntary or compulsory 	<ul style="list-style-type: none"> a. Develop guidelines and schedules for routine operation/maintenance b. Establish operation/maintenance program and Obtain legal authority for right of access to private property
<u>Administer</u> operation/maintenance program	<ul style="list-style-type: none"> a. Establish an operation and maintenance program b. Determine if operation/maintenance program is voluntary or compulsory c. Develop policies for regulating operation/maintenance activities 	<ul style="list-style-type: none"> a. Develop guidelines and schedules for routine operation/maintenance and Impose standards for hauling and disposal of residuals b. Develop system for notifying Owner of required operation/maintenance and Issue a regularly renewed operating permit after certification that proper operation/maintenance has been performed c. Develop training, certification, or licensing program for those contracting to perform operation/maintenance activities

10.4.3.3 Licensure/Registration

To provide assurance that onsite systems are properly operated and maintained, licensing or registering of qualified individuals is desirable. This could be done at the state level. If licensure/registration programs for individuals, such as plumbers, residual waste haulers, sanitarians, etc., already exist, and if these individuals have sufficient knowledge of onsite systems, an additional program may not be necessary.

10.4.4 Rehabilitation

Because onsite systems are usually located on private property and below ground, system failures are difficult to detect. If a management program is to effectively prevent public health hazards, environmental degradation, and nuisances, identification and correction of failures are a necessary part of the management program. Table 10-4 summarizes the suggested activities that should be performed.

TABLE 10-4
REHABILITATION FUNCTIONS

<u>Scope of Activities</u>	<u>Administrative/Technical Activities</u>	<u>Regulatory/Enforcement Activities</u>
Detect and correct improperly functioning systems	a. Develop procedures for identifying improperly functioning systems (Sanitary surveys, presale inspections, etc.)	a. Develop performance standards and Obtain legal authority for right of access to private property
	b. Rehabilitate system	b. Issue order requiring rehabilitation or Rehabilitate system as part of operation/maintenance program

10.4.4.1 Inspections

Inspections could be performed as part of a sanitary survey of the area or through presale inspections during real estate transactions. The latter option may require enabling legislation. Constitutional restraints regarding the inspection of private property and the limitations on the sale of property have to be considered prior to enacting such legislation.

10.4.4.2 Orders and Violations

The management entity needs the authority to issue orders requiring the repair, replacement, or abandonment of improperly functioning systems if the systems are not owned by the entity. Various state agencies have this authority. If the owner does not comply with the order to repair or rehabilitate the system, the management entity could require that copies of all violations be filed with the registrar of deeds or a similar official. The effect of such a filing requirement would be to give notice of the violation in the chain of title whenever an abstract or a title insurance policy is prepared. Any potential mortgagee or buyer would thereby be alerted to the violation.

10.5 References

1. Plews, G. D. The Adequacy and Uniformity of Regulations for On-Site Wastewater Disposal - A State Viewpoint. In: National Conference on Less Costly Wastewater Treatment Systems for Small Communities. EPA 600/9-79-010, NTIS Report No. PB 293 254, April 1977. pp. 20-28.
2. Small Scale Waste Management Project, University of Wisconsin, Madison, Management of Small Waste Flows. EPA 600/2-78-173 NTIS Report No. PB 286 560, September 1978.
3. Interim Study Report, Management of On-Site and Small Community Wastewater Systems. M687, U. S. Environmental Protection Agency, Municipal Environmental Research Laboratory, Cincinnati, Ohio, 1979.

APPENDIX A

SOIL PROPERTIES AND SOIL-WATER RELATIONSHIPS

A.1 Introduction

An understanding of how water moves into and through soil is necessary to predict the potential of soil for wastewater absorption and treatment. Water moves through the voids or pore spaces within soil. Therefore, the size, shape, and continuity of the pore spaces are very important. These characteristics are dependent on the physical properties of the soil and the characteristics of water as well.

A.2 Physical Properties of Soil

A.2.1 Soil Texture

Texture is one of the most important physical properties of soil because of its close relationship to pore size, pore size distribution and pore continuity. It refers to the relative proportion of the various sizes of solid particles in the soil that are smaller than 2 mm in diameter. The particles are commonly divided into three size fractions called soil "separates." These separates are given in Figure A-1. The U.S. Department of Agriculture (USDA) system is used in this manual (Table A-1).

TABLE A-1

U.S. DEPARTMENT OF AGRICULTURE SIZE LIMITS FOR SOIL SEPARATES

<u>Soil Separate</u>	<u>Size Range</u> mm	<u>Tyler Standard</u> <u>Sieve No.</u>
Sand	2-0.05	10-270 mesh
Very coarse sand	2-1	10-16 mesh
Coarse sand	1-0.5	16-35 mesh
Medium sand	0.5-0.25	35-60 mesh
Fine sand	0.25-0.1	60-140 mesh
Very fine sand	0.1-0.05	140-270 mesh
Silt	0.25-0.002	---
Clay	<0.002	---

FIGURE A-1

NAMES AND SIZE LIMITS OF PRACTICAL-SIZE CLASSES ACCORDING TO SIX SYSTEMS (1)

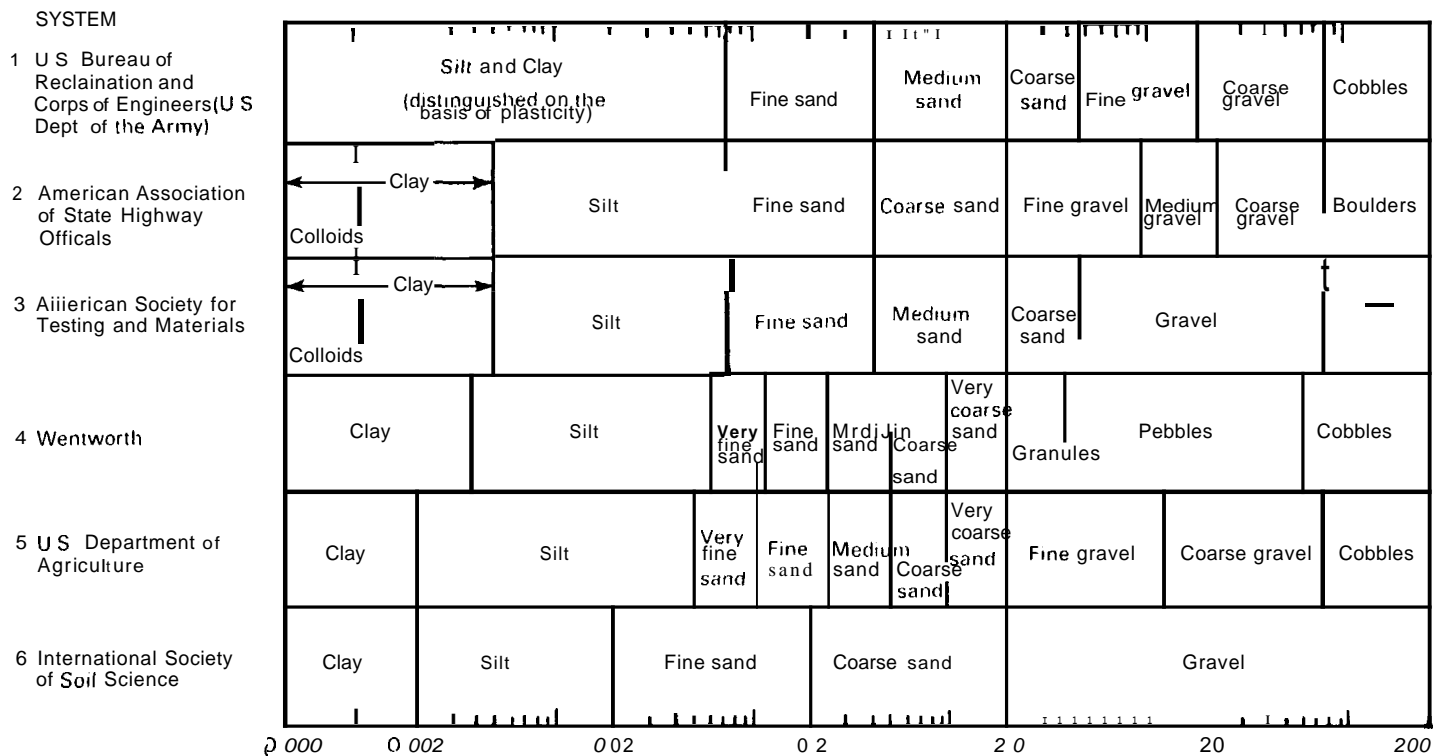

¹ Used in soil engineering

^b Used in geology

^c USDA system used in this manual

^d Used in soil science

Twelve textural classes are defined by the relative proportions of the sand, silt and clay separates. These are represented on the textural triangle (Figure A-2). To determine the textural class of a soil horizon, the percent by weight of the soil separates is needed. For example, a sample containing 37% sand, 45% silt and 18% clay has a textural class of loam. This is illustrated in Figure A-2.

Soil textural classes are modified if particles greater than 2 mm in size are present. The adjectives "gravelly," "cobbley," and "stone" are used for particles between 2 and 75 mm, 75 and 250 mm, or 250 mm, respectively, if more than 15% to 20% of the soil volume is occupied by these fragments.

Soil permeability, aeration and drainage are closely related to the soil texture because of their influence on pore size and pore continuity. They are also related to the soil's ability to filter particles and retain or adsorb pollutants from the waste stream. For example, fine textured or clayey soils do not transmit water rapidly or drain well because the pores are very small. They tend to retain water for long periods of time. However, they act as better filters and can retain more chemicals than soils of other textures. On the other hand, coarse textured or sandy soils have large, continuous pores that can accept and transmit large quantities of water. They retain water for only short periods of time. The capacity to retain chemicals is generally low and they do not filter wastewater as well as finer textured soils. Medium textured or loamy soils have a balance between wastewater absorption and treatment capabilities. They accept and transmit water at moderate rates, act as good filters, and retain moderate amounts of chemical constituents.

A.2.2 Soil Structure

Soil structure has a significant influence on the soil's acceptance and transmission of water. Soil structure refers to the aggregation of soil particles into clusters of particles, called peds, that are separated by surfaces of weakness. These surfaces of weakness open planar pores between the peds that are often seen as cracks in the soil. These planar pores can greatly modify the influence of soil texture on water movement. Well structured soils with large voids between peds will transmit water more rapidly than structureless soils of the same texture, particularly if the soil has become dry before the water is added. Fine textured, massive soils (soils with little structure) have very slow percolation rates.

FIGURE A-2

TEXTURAL TRIANGLE DEFINING TWELVE TEXTURAL CLASSES OF THE USDA
(ILLUSTRATED FOR A SAMPLE CONTAINING 37% SAND, 45% SILT, AND 18% CLAY)

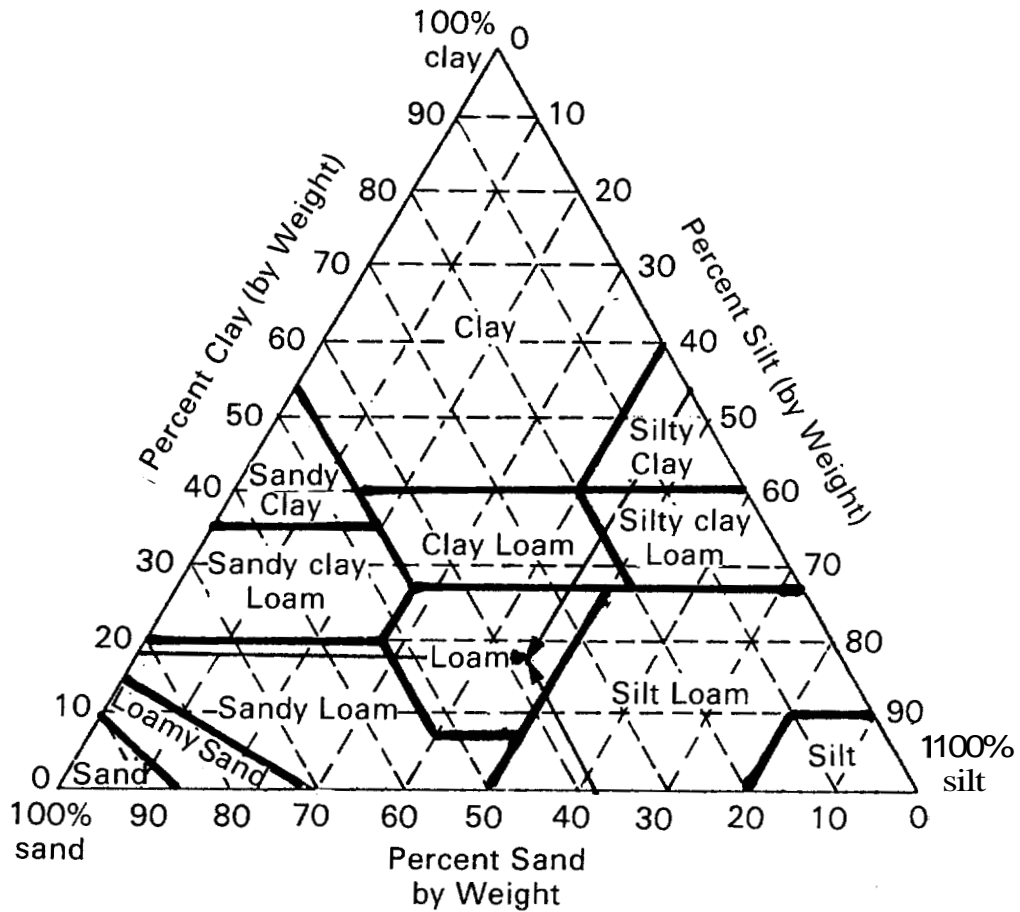

The form, size and stability of the aggregates or peds depend on the arrangement of the soil particles and the bonds between the particles. The four major types of structures include platy, blocky, prismatic and granular. Detailed descriptions of types and classes of soil structure used by SCS are given in Table A-2.

Between the peds are voids which are often relatively large and continuous compared to the voids or pores between the primary particles within the peds. The type of structure determines the dominant direction of the pores and, hence, water movement in the soil. Platy structures restrict vertical percolation of water because cleavage faces are horizontally oriented. Often, vertical flow is so restricted that the upper soil horizons saturate, creating a perched water table. Soils with prismatic and columnar structure enhance vertical water flow, while blocky and granular structures enhance flow both horizontally and vertically.

The soil's permeability by air and water is also influenced by the frequency and degree of expression of the pores created by the structural units. These characteristics depend upon the size of the peds and their grade or durability. Small structural units create more pores in the soil than large structural units. Soils with strong structure have distinct pores between peds. Soils with very weak structure, or soils without peds or planes of weakness, are said to be structureless. Structureless sandy soils are called single grained or granular, while structureless clayey soils are called massive.

Structure is one soil characteristic that is easily altered or destroyed. It is very dynamic, changing in response to moisture content, chemical composition of soil solution, biological activity, and management practices. Soils containing minerals that shrink and swell appreciably, such as montmorillonite clays, show particularly dramatic changes. When the soil peds swell upon wetting, the large pores become smaller, and water movement through the soil is reduced. Swelling can also result if the soil contains a high proportion of sodium salts. Therefore, when determining the hydraulic properties of a soil for wastewater disposal, soil moisture contents and salt concentrations should be similar to that expected in the soil surrounding a soil disposal system.

A.2.3 Soil Color

The color and color patterns in soil are good indicators of the drainage characteristics of the soil. Soil properties, location in the landscape, and climate all influence water movement in the soil. These factors cause some soils to be saturated or seasonally saturated, affecting

TABLE A-2
TYPES AND CLASSES OF SOIL STRUCTURE

TYPE (shape and arrangement of peds)							
Class	Platelike, with one dimension (the vertical) limited and greatly less than the other two; arranged around a horizontal plane faces mostly horizontal	Prismlike, with two dimensions (the horizontal) limited and considerably less than the vertical, arranged around a vertical line, vertical faces well defined, vertices angular	Blocklike, polyhedronlike, or spheroids, or with three dimensions of the same order of magnitude, arranged around a point				
		Without rounded caps	With rounded caps	Faces flattened, most vertices sharply angular	Mixed rounded and flattened faces with many rounded vertices	Nonporous peds	Porous peds
	Platy	Prismatic	Columnar	(Angular) Blocky*	(Subangular) Blocky+	Granular	Crumb
Very fine or very thin	Very thin platy; <1 mm	Very fine prismatic; <10 mm	Very fine columnar; (10 mm	Very fine angular blocky; <5 mm	Very fine subangular blocky; <5 mm	Very fine angular; <1 mm	Very fine crumb; <1 mm
Fine or thin	Thin platy, 1 to 2 mm	Fine prismatic, 10 to 20 mm	Fine Columnar, 10 to 20 mm	Fine angular blocky, 5 to 10 mm	Fine sub angular blocky, 5 to 10 mm	Fine granular, 1 to 2 mm	Fine crumb, 1 to 2 mm
Medium	Medium platy; 2 to 5 mm	Medium prismatic, 20 to 50 mm	Medium columnar; 20 to 50 mm	Medium angular blocky; 10 to 20 mm	Medium subangular blocky; 10 to 20 mm	Medium granular; 2 to 5 mm	Medium crumb; 2 to 5 mm
Coarse or thick	Thick platy; 5 to 10 mm	Coarse prismatic; 50 to 100 mm	Coarse columnar; 50 to 100 mm	Coarse angular blocky; 20 to 50 mm	Coarse subangular; 20 to 50 mm	Coarse granular; 5 to 10 mm	
Very coarse or very thick	Very thick platy, > 10 mm	Very coarse prismatic, >100 mm	Very coarse columnar, >100 mm	Very coarse angular blocky, > 50 mm	Very coarse subangular blocky, >50 mm	Very coarse granular, >10 mm	

Source Soil Survey Staff 1960

*(a) Sometimes called nut (b) The word 'angular' in the name can ordinarily be omitted

+ Sometimes called nuciform, nut or subangular, nut. Since the size connotation of these terms is a source of great confusion to many, they are not recommended

their ability to absorb and treat wastewater. Interpretation of soil color aids in identifying these conditions.

Soil colors are a result of the color of primary soil particles, coatings of iron and manganese oxides, and organic matter on the particles. Soils that are seldom or never saturated with water and are well aerated, are usually uniformly red, yellow or brown in color. Soils that are saturated for extended periods or all the time are often grey or blue in color. Color charts have been developed for identifying the various soil colors.

Soils that are saturated or nearly saturated during portions of the year often have spots or streaks of different colors called mottles. Mottles are useful to determine zones of saturated soil that may occur only during wet periods. Mottles result from chemical and biochemical reactions when saturated conditions, organic matter, and temperatures above 4° C occur together in the soil. Under these conditions, the bacteria present rapidly deplete any oxygen present while feeding on the organic matter. When the oxygen is depleted, other bacteria continue the organic decomposition using the oxidized iron and manganese compounds, rather than oxygen, in their metabolism. Thus, the insoluble oxidized iron and manganese, which contribute much of the color to soil, are reduced to soluble compounds. This causes the soil to lose its color, turning the soil grey. When the soil drains, the soluble iron and magnesium are carried by the water to the larger soil pores. Here they are reoxidized when they come in contact with the oxygen introduced by the air-filled pores, forming insoluble compounds once again. The result is the formation of red, yellow and black spots near surfaces, and the loss of color, or greying, at the sites where the iron and manganese compounds were removed. (Examples of mottled soils are shown in Figure 3-20). Therefore, mottles seen in unsaturated soils can be interpreted as an indication that the soil is periodically saturated. Periodic saturation of soil cannot always be identified by mottles, however. Some soils can become saturated without the formation of mottles, because one of the conditions needed for mottle formation is not present. Experience and knowledge of moisture regimes related to landscape position and other soil characteristics are necessary to make proper interpretations in these situations.

Also, color spots and streaks can be present in soils for reasons other than soil saturation. For example, soil parent materials sometimes create a color pattern in the soil similar to mottling. However, these patterns usually can be distinguished from true mottling. Some very sandy soils have uniform grey colors because there are no surface coatings on the sand grains. This color can mistakenly be interpreted as a gley or a poor draining color. Direct measurement of zones of soil

saturation may be necessary to confirm the soil moisture regimes if interpretations of soil colors are not possible.

A.2.4 Soil Horizons

A soil horizon is a layer of soil approximately parallel to the soil surface with uniform characteristics. Soil horizons are identified by observing changes in soil properties with depth. Soil texture, structure, and color changes are some of the characteristics used to determine soil horizons.

Soil horizons are commonly given the letter designations of A, B, and C to represent the surface soil, subsoil, and substratum, respectively. Not all soils have all three horizons. On the other hand, many soils show variations within each master horizon and are subdivided as A1, A2, A3, and B1, etc. Some example soils and their horizons are shown in Figure A-3.

Each horizon has its own set of characteristics and therefore will respond differently to applied wastewater. Also, the conditions created at the boundary between soil horizons can significantly influence wastewater flow and treatment through the soil. Therefore, an evaluation of a soil must include a comparison of the physical properties of each horizon that influences absorption and treatment of wastewater.

A.2.5 Other Selected Soil Characteristics

Bulk density and clay mineralogy are other soil characteristics that can significantly influence water infiltration and percolation in soils. Soil bulk density is the ratio of the mass of soil to its bulk or volume occupied by the soil mass and pore space. There is not a direct correlation between bulk density and soil permeability, since sandy soils generally have a higher bulk density and permeability than clayey soils. However, of soils with the same texture, those soils with the higher bulk densities are more compact with less pore volume. Reduced porosity reduces the hydraulic conductivity of the soil. Fragipans are examples of horizons that have high bulk densities and reduced permeabilities. They are very compact horizons rich in silt and/or sand but relatively low in clay, which commonly interferes with water and root penetration.

The mineralogy of clay present in the soil can have a very significant influence on water movement. Some clay minerals shrink and swell appreciably with changes in water content. Montmorillonite is the most common of these swelling clay minerals. Even if present in small amounts,

FIGURE A-3

SCHEMATIC DIAGRAM OF A LANDSCAPE
AND DIFFERENT SOILS POSSIBLE

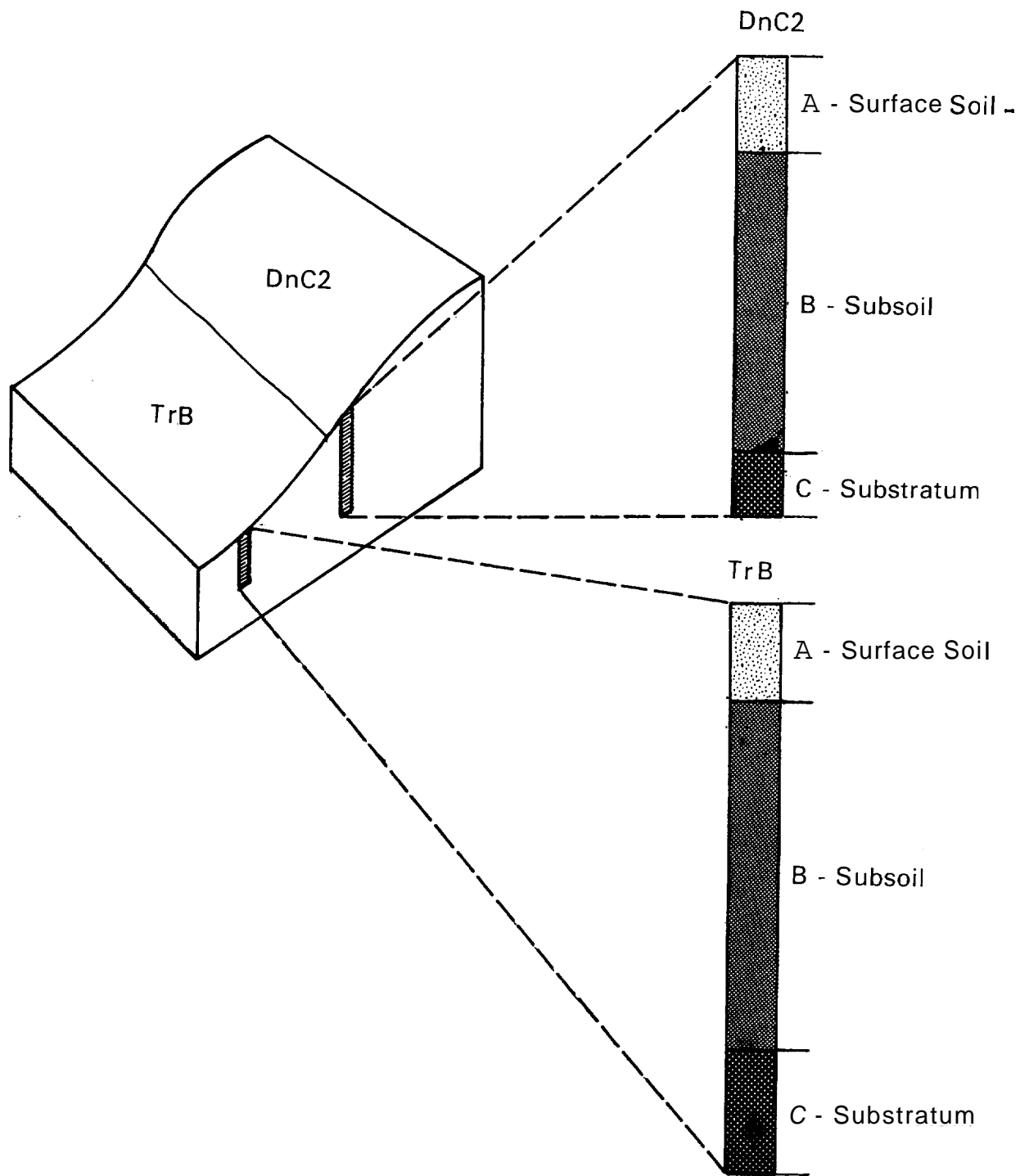

the porosity of soils containing montmorillonite can vary dramatically with varying moisture content. When dry, the clay particles shrink, opening the cracks between peds. But when wet, the clay swells, closing the pores.

A.3 Water in the Soil System

A.3.1 Soil Moisture Potential

Soil permeability, or the capability of soil to conduct water, is not determined by the soil porosity but, rather, the size, continuity, and tortuosity of the pores. A clayey soil is more porous than a sandy soil, yet the sandy soil will conduct much more water because it has larger, more continuous pores. Under natural drainage conditions, some pores in the soil are filled with water. The distribution of this water depends upon the characteristics of the pores, while its movement is determined by the relative energy status of the water. Water flows from points of higher energy to points of lower energy. The energy status is referred to as the moisture potential.

The total soil moisture potential has several components, of which the gravitational and matric potential are the most important. The gravitational potential is the result of the attraction of water toward the center of the earth by a gravitational force and is equal to the weight of water. The potential energy of the water at any point is determined by the elevation of that point relative to some reference level. Thus, the higher the water above this reference, the greater its gravitational potential.

The matric potential is produced by the affinity of water molecules to each other and to solid surfaces. Molecules within the body of water are attracted to other molecules by cohesive forces, while water molecules in contact with solid surfaces are more strongly attracted to the solid surfaces by adhesive forces. The result of these forces acting together draws water into the pores of the soil. The water tries to wet the solid surfaces of the pores due to adhesive forces and pulls other molecules with it due to cohesive forces. This phenomenon is referred to as capillary rise. The rise of water is halted when the weight of the water column is equal to the force of capillarity. Therefore, water rises higher and is held tighter in smaller pores than in larger pores (see Figure A-4). Upon draining, the largest pores empty first because they have the weakest hold on the water. Therefore, in unsaturated soils, the water is held in the finer pores because they are better able to retain the water against the forces of gravity.

FIGURE A-4

UPWARD MOVEMENT BY CAPILLARITY IN GLASS
TUBES AS COMPARED WITH SOILS (2)

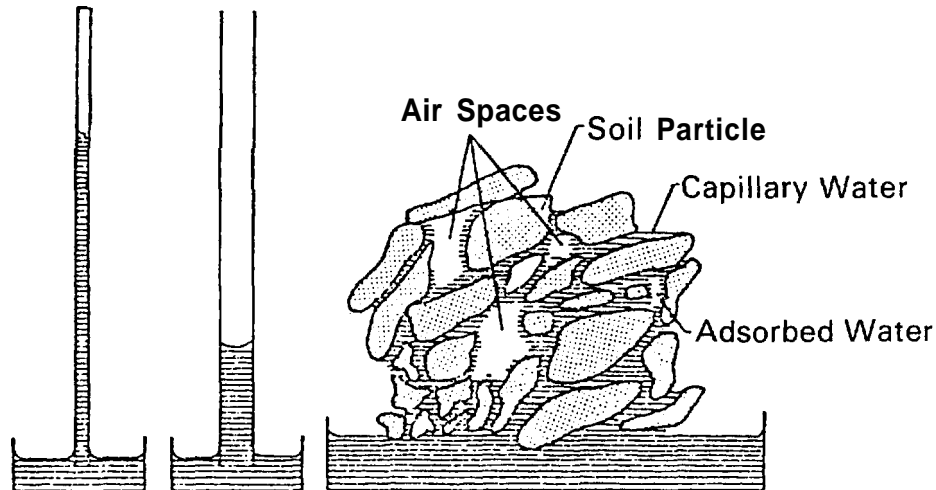

The ability of the soil to draw or pull water into its pores is referred to as its matric potential. Since the water is held against the force of gravity, it has a pressure less than atmospheric. This negative pressure is often referred to as soil suction or soil moisture tension. Increasing suction or tension is associated with soil drying.

The moisture content of soils with similar moisture tensions varies with the nature of the pores. Figure A-5 illustrates the change in moisture content versus changes in moisture tensions. When the soil is saturated, all the pores are filled with water and no capillary suction occurs. The soil moisture tension is zero. When drainage occurs, the tensions increase. Because the sand has many relatively large pores, it drains abruptly at relatively low tensions, whereas the clay releases only a small volume of water over a wide tension range because most of it is strongly retained in very fine pores. The silt loam has more coarse pores than does the clay, so its curve lies somewhat below that of the clay. The sandy loam has more finer pores than the sand so its curve lies above that of the sand.

FIGURE A-5

SOIL MOISTURE RETENTION FOR FOUR DIFFERENT SOIL TEXTURES (3)

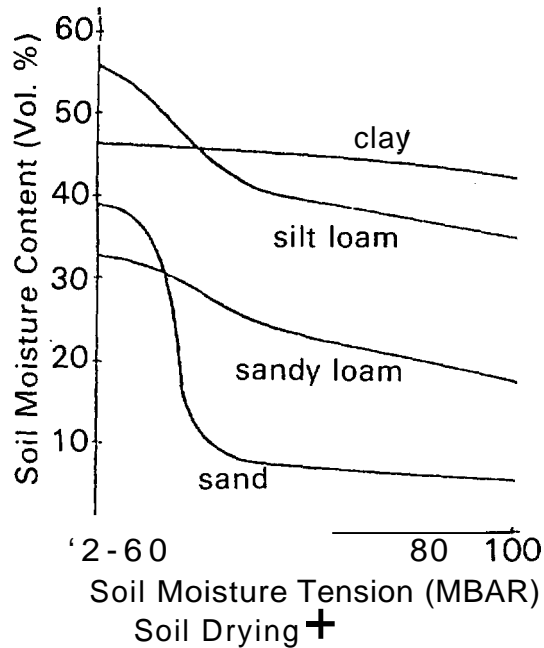

A.3.2 Flow of Water in Soil

The flow of water in soil depends on the soil's ability to transmit the water and the presence of a force to drive it. Hydraulic conductivity is defined as the soil's ability to transmit water, and is related to the number, size, and configuration of the pores. Soils with large, continuous water-filled pores can transmit water easily and have a high conductivity. While soils with small, discontinuous water-filled pores offer a high resistance to flow, and, therefore, have low conductivity. When the soil is saturated, all pores are water-filled and the conductivity depends on all the soil pores. When the soil becomes unsaturated or dries (see Figure A-5), the larger pores fill with air, and only the smaller water-filled pores may transmit the water. Therefore, as seen in Figure A-6, the hydraulic conductivity decreases for all soils as they dry. Since clayey soils have more fine pores than sandy soils, the hydraulic conductivity of a clay is greater than a sand beyond a soil moisture tension of about 50 mbar.

FIGURE A-6

HYDRAULIC CONDUCTIVITY (K) VERSUS
SOIL MOISTURE RETENTION (4)

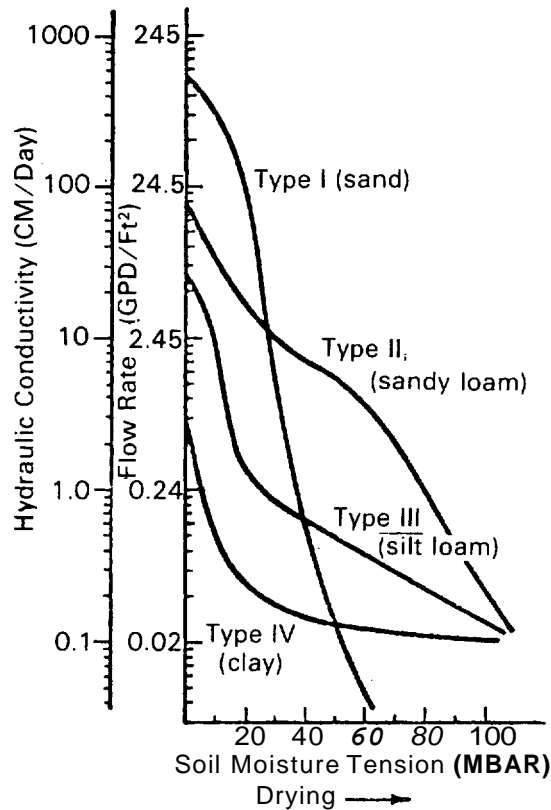

Water movement in soil is governed by the total moisture potential gradient and the soil's hydraulic conductivity. The direction of movement is from a point of higher potential (gravity plus matric potential) to a point of lower potential. When the soil is saturated, the matric potential is zero, so the water moves downward due to gravity. If the soil is unsaturated, both the gravity and matric potentials determine the direction of flow, which may be upward, sideward, or downward depending on the difference in total potentials surrounding the area. The greater the difference in potentials between two points, the more rapid the movement. However, the volume of water moved in a given time is proportional to the total potential gradient and the soil's hydraulic conductivity at the given moisture content. Therefore, soils with greater hydraulic conductivities transmit larger quantities of water at the same potential gradient than soils with lower hydraulic conductivities.

A.3.3 Flow of Water Through Layered Soils

Soil layers of varying hydraulic conductivities interfere with water movement. Abrupt changes in conductivity can cause the soil to saturate or nearly saturate above the boundary regardless of the hydraulic conductivity of the underlying layer. If the upper layer has a significantly greater hydraulic conductivity, the water ponds because the lower layer cannot transmit the water as fast as the upper layer delivers it. If the upper layer has a lower conductivity, the underlying layer cannot absorb it because the finer pores in the upper layer hold the water until the matric potential is reduced to near saturation.

Layers such as these may occur naturally in soils or as the result of continuous wastewater application. It is common to develop a clogging mat of lower hydraulic conductivity at the infiltrative surface of a soil disposal system. This layer forms as a result of suspended solids accumulation, biological activity, compaction by construction machinery, and soil slaking (3). The clogging mat may restrict water movement to the point where water is ponded above, and the soil below is unsaturated. Water passes through the clogging mat due to the hydrostatic pressure of the ponded water above pushing the water through, and the soil suction of the unsaturated soil below pulling it through.

Figure A-7 illustrates three columns of similar textured soils with clogging mats in various stages of development. Water is ponded at equal heights above the infiltrative surface of each column.

Column A has no clogging mat so the water is able to pass through all the pores, saturating the soil. The moisture tension in this column is zero. Column B has a permeable clogging mat developed with moderate size pores. Flow into the underlying soil is restricted by the clogging mat to a rate less than the soil is able to transmit it. Therefore, the large pores in the soil are empty. With increasing intensity of the mat, as shown in Column C, the flow rate through the soil is reduced to very low levels. The water is forced to flow through the finest pores of the soil, which is a very tortuous path. Flow rates through identical clogging mats developed on different soils will vary with the soil's capillary characteristics.

A.4 Evaluating Soil Properties

To adequately predict how soil responds to wastewater application, the soil properties described and other site characteristics must be identified. The procedures used to evaluate soils are described in Chapter 3 of this manual.

FIGURE A-7

SCHMATIC REPRESENTATION OF WATER MOVEMENT THROUGH
A SOIL WITH CRUSTS OF DIFFERENT RESISTANCES

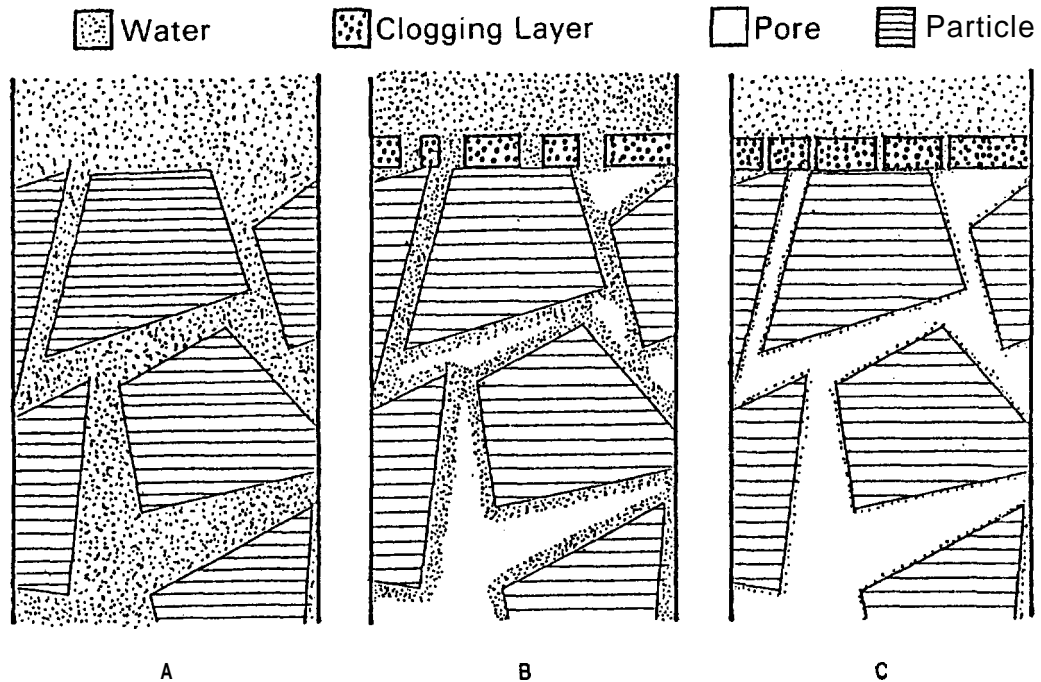

A. 5 References

1. Black, C. A. Soil Plant Relationships. 2nd ed. Wiley, New York, 1968. 799 pp.
2. Brady, N. C. The Nature and Properties of Soils. 8th ed. MacMillan, New York, 1974. 655 pp.
3. Bouma, J. W., A. Ziebell, W. G. Walker, P. G. Olcott, E. McCoy, and F. D. Hole. Soil Absorption of Septic Tank Effluent. Information Circular 20, Wisconsin Geological and Natural History Survey, Madison, 1972. 235 pp.
4. Bouma, J. Unsaturated Flow During Soil Treatment of Septic Tank Effluent. J. Environ. Eng., Am. Soc. Civil Eng., 101:967-983, 1975.

GLOSSARY

A horizon: The horizon formed at or near the surface, but within the mineral soil, having properties that reflect the influence of accumulating organic matter or eluviation, alone or in combination.

absorption: The process by which one substance is taken into and included within another substance, as the absorption of water by soil or nutrients by plants.

activated sludge process: A biological wastewater treatment process in which a mixture of wastewater and activated sludge is agitated and aerated. The activated sludge is subsequently separated from the treated wastewater (mixed liquor) by sedimentation and wasted or returned to the process as needed.

adsorption: The increased concentration of molecules or ions at a surface, including exchangeable cations and anions on soil particles.

aerobic: (1) Having molecular oxygen as a part of the environment. (2) Growing or occurring only in the presence of molecular oxygen, such as aerobic organisms.

aggregate, soil: A group of soil particles cohering so as to behave mechanically as a unit.

anaerobic: (1) The absence of molecular oxygen. (2) Growing in the absence of molecular oxygen (such as anaerobic bacteria).

anaerobic contact process: An anaerobic waste treatment process in which the microorganisms responsible for waste stabilization are removed from the treated effluent stream by sedimentation or other means, and held in or returned to the process to enhance the rate of treatment.

angstrom (\AA): one hundred millionth of a centimeter.

B horizon: The horizon immediately beneath the A horizon characterized by a higher colloid (clay or humus) content, or by a darker or brighter color than the soil immediately above or below, the color usually being associated with the colloidal materials. The colloids may be of alluvial origin, as clay or humus; they may have been formed in place (clays, including sesquioxides); or they may have been derived from a texturally layered parent material.

- biochemical oxygen demand (BOD) : Measure of the concentration of organic impurities in wastewater. The amount of oxygen required by bacteria while stabilizing organic matter under aerobic conditions, expressed in mg/l, is determined entirely by the availability of material in the wastewater to be used as biological food, and by the amount of oxygen utilized by the microorganisms during oxidation.
- blackwater: Liquid and solid human body waste and the carriage waters generated through toilet usage.
- bulk density, soil: The mass of dry soil per unit bulk volume. The bulk volume is determined before drying to constant weight at 105°C.
- C horizon: The horizon that normally lies beneath the B horizon but may lie beneath the A horizon, where the only significant change caused by soil development is an increase in organic matter, which produces an A horizon. In concept, the C horizon is unaltered or slightly altered parent material.
- calcareous soil: Soil containing sufficient calcium carbonate (often with magnesium carbonate) to effervesce visibly when treated with cold 0.1N hydrochloric acid.
- capillary attraction: A liquid's movement over, or retention by, a solid surface, due to the interaction of adhesive and cohesive forces.
- cation exchange: The interchange between a cation in solution and another cation on the surface of any surface-active material, such as clay or organic colloids.
- cation-exchange capacity: The sum total of exchangeable cations that a soil can adsorb; sometimes called total-exchange, base-exchange capacity, or cation-adsorption capacity. Expressed in milliequivalents per 100 grams or per gram of soil (or of other exchanges, such as clay).
- chemical oxygen demand (COD): A measure of the oxygen equivalent of that portion of organic matter that is susceptible to oxidation by a strong chemical oxidizing agent.
- chlorine residual: The total amount of chlorine (combined and free available chlorine) remaining in water, sewage, or industrial wastes at the end of a specified contact period following chlorination.
- clarifiers: Settling tanks. The purpose of a clarifier is to remove settleable solids by gravity, or colloidal solids by coagulation

following chemical flocculation; will also remove floating oil and scum through skimming.

clay: (1) A soil separate consisting of particles <0.002 mm in equivalent diameter. (2) A textural class.

clay mineral : Naturally occurring inorganic crystalline or amorphous material found in soils and other earthy deposits, the particles being predominantly <0.002 mm in diameter. Largely of secondary origin.

coarse texture: The texture exhibited by sands, loamy sands, and sandy loams except very fine sandy loams.

coliform-group bacteria: A group of bacteria predominantly inhabiting the intestines of man or animal, but also occasionally found elsewhere. Used as an indicator of human fecal contamination.

colloids: The finely divided suspended matter which will not settle, and the apparently dissolved matter which may be transformed into suspended matter by contact with solid surfaces or precipitated by chemical treatment. Substances which are soluble as judged by ordinary physical tests, but will not pass through a parchment membrane.

columnar structure: A soil structural type with a vertical axis much longer than the horizontal axes and a distinctly rounded upper surface.

conductivity, hydraulic: As applied to soils, the ability of the soil to transmit water in liquid form through pores.

consistence: (1) The resistance of a material to deformation or rupture. (2) The degree of cohesion or adhesion of the soil mass.

Terms used for describing consistence at various soil moisture contents are:

wet soil : Nonsticky, slightly sticky, sticky, very sticky, nonplastic, slightly plastic, plastic, and very plastic.

moist soil: Loose, very friable, friable, firm, very firm, and extremely firm.

dry soil: Loose, soft, slightly hard, hard, very hard, and extremely hard.

cementation: Weakly cemented, strongly cemented, and indurated.

crumb: A soft, porous, more or less rounded ped from 1 to 5 mm in diameter.

crust: A surface layer on soils, ranging in thickness from a few millimeters to perhaps as much as an inch, that is much more compact, hard, and brittle when dry, than the material immediately beneath it.

denitrification: The biochemical reduction of nitrate or nitrite to gaseous molecular nitrogen or an oxide of nitrogen.

digestion: The biological decomposition of organic matter in sludge, resulting in partial gasification, liquefaction, and mineralization.

disinfection: Killing pathogenic microbes on or in a material without necessarily sterilizing it.

disperse: To break up compound particles, such as aggregates, into the individual component particles.

dissolved oxygen (DO): The oxygen dissolved in water, wastewater, or other liquid, usually expressed in milligrams per liter (mg/l), parts per million (ppm), or percent of saturation.

dissolved solids: Theoretically, the anhydrous residues of the dissolved constituents in water. Actually, the term is defined by the method used in determination.

effluent: Sewage, water, or other liquid, partially or completely treated or in its natural state, flowing out of a reservoir, basin, or treatment plant.

effective size: The size of grain such that 10% of the particles by weight are smaller and 90% greater.

eutrophic: A term applied to water that has a concentration of nutrients optimal, or nearly so, for plant or animal growth.

evapotranspiration: The combined loss of water from a given area, and during a specified period of time, by evaporation from the soil surface and by transpiration from plants.

extended aeration: A modification of the activated sludge process which provides for aerobic sludge digestion within the aeration system.

filtrate: The liquid which has passed through a filter.

fine texture: The texture exhibited by soils having clay as a part of their textural class name.

floodplain: Flat or nearly flat land on the floor of a river valley that is covered by water during floods.

floodway: A channel built to carry excess water from a stream.

food to microorganism ratio (F/M): Amount of BOD applied to the activated sludge system per day per amount of MLSS in the aeration basin, expressed as lb BOD/d/lb MLSS.

graywater: Wastewater generated by water-using fixtures and appliances, excluding the toilet and possibly the garbage disposal.

hardpan: A hardened soil layer, in the lower A or in the B horizon, caused by cementation of soil particles with organic matter or with materials such as silica, sesquioxides, or calcium carbonate. The hardness does not change appreciably with changes in moisture content, and pieces of the hard layer do not slake in water.

heavy soil: (Obsolete in scientific use.) A soil with a high content of the fine separates, particularly clay, or one with a high drawbar pull and hence difficult to cultivate.

hydraulic conductivity: See conductivity, hydraulic.

impervious: Resistant to penetration by fluids or by roots.

influent: Water, wastewater, or other liquid flowing into a reservoir, basin, or treatment plant.

intermittent filter: A natural or artificial bed of sand or other fine-grained material to the surface of which wastewater is applied intermittently in flooding doses and through which it passes; opportunity is given for filtration and the maintenance of an aerobic condition.

ion: A charged atom, molecule, or radical, the migration of which affects the transport of electricity through an electrolyte or, to a certain extent, through a gas. An atom or molecule that has lost or gained one or more electrons; by such ionization it becomes electrically charged. An example is the alpha particle.

ion exchange: A chemical process involving reversible interchange of ions between a liquid and a solid but no radical change in structure of the solid.

leaching: The removal of materials in solution from the soil.

lysimeter: A device for measuring percolation and leaching losses from a column of soil under controlled conditions.

manifold: A pipe fitting with numerous branches to convey fluids between a large pipe and several smaller pipes, or to permit choice of diverting flow from one of several sources or to one of several discharge points.

mapping unit: A soil or combination of soils delineated on a map and, where possible, named to show the taxonomic unit or units included. Principally, mapping units on maps of soils depict soil types, phases, associations, or complexes.

medium texture: The texture exhibited by very fine sandy loams, loams, silt loams, and silts.

mineral soil: A soil consisting predominantly of, and having its properties determined by, mineral matter. Usually contains <20 percent organic matter, but may contain an organic surface layer up to 30 cm thick.

mineralization: The conversion of an element from an organic form to an inorganic state as a result of microbial decomposition.

mineralogy, soil: In practical use, the kinds and proportions of minerals present in soil.

mixed liquor suspended solids (MLSS): Suspended solids in a mixture of activated sludge and organic matter undergoing activated sludge treatment in the aeration tank.

montmorillonite: An aluminosilicate clay mineral with a 2:1 expanding structure; that is, with two silicon tetrahedral layers enclosing an aluminum octahedral layer. Considerable expansion may be caused by water moving between silica layers of contiguous units.

mottling: Spots or blotches of different color or shades of color interspersed with the dominant color.

nitrification: The biochemical oxidation of ammonium to nitrate.

organic nitrogen: Nitrogen combined in organic molecules such as proteins, amino acids.

organic soil: A soil which contains a high percentage (>15 percent or 20 percent) of organic matter throughout the solum.

particle size: The effective diameter of a particle usually measured by sedimentation or sieving.

particle-size distribution: The amounts of the various soil separates in a soil sample, usually expressed as weight percentage.

pathogenic: Causing disease. "Pathogenic" is also used to designate microbes which commonly cause infectious diseases, as opposed to those which do so uncommonly or never.

- ped: A unit of soil structure such as an aggregate, crumb, prism, block, or granule, formed by natural processes (in contrast with a clod, which is formed artificially).
- pedon: The smallest volume (soil body) which displays the normal range of variation in properties of a soil. Where properties such as horizon thickness vary little along a lateral dimension, the pedon may occupy an area of a square yard or less. Where such a property varies substantially along a lateral dimension, a large pedon several square yards in area may be required to show the full range in variation.
- percolation: The flow or trickling of a liquid downward through a contact or filtering medium. The liquid may or may not fill the pores of the medium.
- permeability, soil: The ease with which gases, liquids, or plant roots penetrate or pass through soil.
- pH: A term used to describe the hydrogen-ion activity of a system.
- plastic soil: A soil capable of being molded or deformed continuously and permanently, by relatively moderate pressure, into various shapes. See consistence.
- platy structure: Soil aggregates that are developed predominantly along the horizontal axes; laminated; flaky.
- settleable solids: That matter in wastewater which will not stay in suspension during a preselected settling period, such as one hour, but either settles to the bottom or floats to the top.
- silt: (1) A soil separate consisting of particles between 0.05 and 0.002 mm in diameter. (2) A soil textural class.
- single-grained: A nonstructural state normally observed in soils containing a preponderance of large particles, such as sand. Because of a lack of cohesion, the sand grains tend not to assemble in aggregate form.
- siphon: A closed conduit a portion of which lies above the hydraulic grade line, resulting in a pressure less than atmospheric and requiring a vacuum within the conduit to start flow. A siphon utilizes atmospheric pressure to effect or increase the flow of water through the conduit.
- slope: Deviation of a plane surface from the horizontal.
- soil horizon: A layer of soil or soil material approximately parallel to the land surface and differing from adjacent genetically related

- layers in physical, chemical, and biological properties or characteristics such as color, structure, texture, consistence, pH, etc.
- soil map: A map showing the distribution of soil types or other soil mapping units in relation to the prominent physical and cultural features of the earth's surface.
- soil morphology: The physical constitution, particularly the structural properties, of a soil profile as exhibited by the kinds, thickness, and arrangement of the horizons in the profile, and by the texture, structure, consistence, and porosity of each horizon.
- soil separates: Groups of mineral particles separated on the basis of a range in size. The principal separates are sand, silt, and clay.
- soil series: The basic unit of soil classification, and consisting of soils which are essentially alike in all major profile characteristics, although the texture of the A horizon may vary somewhat. See soil type.
- soil solution: The aqueous liquid phase of the soil and its solutes consisting of ions dissociated from the surfaces of the soil particles and of other soluble materials.
- soil structure: The combination or arrangement of individual soil particles into definable aggregates, or peds, which are characterized and classified on the basis of size, shape, and degree of distinctness.
- soil suction: A measure of the force of water retention in unsaturated soil. Soil suction is equal to a force per unit area that must be exceeded by an externally applied suction to initiate water flow from the soil. Soil suction is expressed in standard pressure terms.
- soil survey: The systematic examination, description, classification, and mapping of soils in an area.
- soil texture: The relative proportions of the various soil separates in a soil.
- soil type: In mapping soils, a subdivision of a soil series based on differences in the texture of the A horizon.
- soil water: A general term emphasizing the physical rather than the chemical properties and behavior of the soil solution.

solids: Material in the solid state.

total: The solids in water, sewage, or other liquids; includes suspended and dissolved solids; all material remaining as residue after water has been evaporated.

dissolved: Solids present in solution.

suspended: Solids physically suspended in water, sewage, or other liquids. The quantity of material deposited when a quantity of water, sewage, or liquid is filtered through an asbestos mat in a Gooch crucible.

volatile: The quantity of solids in water, sewage, or other liquid lost on ignition of total solids.

solids retention time (SRT): The average residence time of suspended solids in a biological waste treatment system, equal to the total weight of suspended solids in the system divided by the total weight of suspended solids leaving the system per unit time (usually per day).

subsoil: In general concept, that part of the soil below the depth of plowing.

tensiometer: A device for measuring the negative hydraulic pressure (or tension) of water in soil in situ; a porous, permeable ceramic cup connected through a tube to a manometer or vacuum gauge.

tension, soil water: The expression, in positive terms, of the negative hydraulic pressure of soil water.

textural class, soil: Soils grouped on the basis of a specified range in texture. In the United States, 12 textural classes are recognized.

texture: See soil texture.

tight soil: A compact, relatively impervious and tenacious soil (or subsoil), which may or may not be plastic.

Total Kjeldahl Nitrogen (TKN): An analytical method for determining total organic nitrogen and ammonia.

topsoil: (1) The layer of soil moved in cultivation. (2) The A horizon. (3) The A1 horizon. (4) Presumably fertile soil material used to topdress roadbanks, gardens, and lawns.

uniformity coefficient (UC): The ratio of that size of grain that has 60% by weight finer than itself, to the size which has 10% finer than itself.

unsaturated flow: The movement of water in a soil which is not filled to capacity with water.

vapor pressure: (1) The pressure exerted by a vapor in a confined space. It is a function of the temperature. (2) The partial pressure of water vapor in the atmosphere. (3) Partial pressure of any liquid.

water table: That level in saturated soil where the hydraulic pressure is zero.

water table, perched: The water table of a discontinuous saturated zone in a soil.