

Oxfam Water Supply Scheme for Emergencies

Instruction manual for

Hand Dug Well Equipment

Covering well auger survey, well digging,
dewatering and desludging kits



An Oxfam Technical Manual

H
Humanitarian Department

Oxfam Water Supply Scheme for Emergencies

Instruction manual for

Hand Dug Well Equipment

Covering well auger survey, well digging, dewatering and desludging kits

This equipment is part of several packages devised by the Oxfam Public Health Engineering Team to help provide a reliable water supply for populations affected by conflict or natural disaster. The equipment is designed to be used with any or all of the following Oxfam water equipment: Water Storage equipment, Water Coagulation and Disinfection equipment, Water Filtration equipment, Water Distribution equipment, Water Pumping equipment, and Water Testing Kit. All are designed using available, easily transported equipment which is simple, rapidly assembled, and fully self-contained, to provide an adequate, safe water supply at moderate cost. The principles used in these packages may often be useful in long-term development projects.

The Oxfam equipment packages, which consist of "Oxfam" tanks (steel sheets, rubber liners), diesel water pumps, 3" PVC pipes etc, have been used successfully in the last two decades in often harsh environments, ranging from tropical to temperate climatic areas. Although this equipment is designed for emergencies, if installed and protected adequately it can give many years of useful service, though some up-grading works will be necessary to prolong its life. This equipment can be dismantled and re-used elsewhere. However, these Oxfam equipment packages, while being simple to erect over a period of days, yet durable enough to last several years, do not lend themselves to very rapid deployment in a few hours. Increasingly, the nature of work which Oxfam has been called on to undertake has required equipment that can rapidly deployed then dismantled and moved to other locations. This has led to the development of the so called "rapid response kits" since the mid-1990s. This type of equipment is seen as a necessary complement to the original Oxfam equipment and is best used to provide a start up package in the absence of a detailed assessment and where affected populations are likely to be highly mobile. The relatively higher equipment costs and lack of suitability for anything other than short term water supply means that the deployment of the "rapid response kits" should be used only where appropriate.

Contents

SECTION A – EQUIPMENT USE AND SYSTEM DESIGN	2
Introduction	2
SECTION B – LIST OF KITS AND INSTRUCTIONS FOR USE	5
Survey auger kit	5
Well lining kits	18
Well dewatering kit	21
Dewatering/desludging kit	29
SECTION C – SAFETY INFORMATION	31
SECTION D – DETAILS OF KITS AND SUPPLIERS	34
Full list of kit contents	34
List of Suppliers used by Oxfam	38
Final reminders and recommendations, acknowledgements and references	39

SECTION A - EQUIPMENT USE AND SYSTEM DESIGN

Introduction

This package of equipment has been prepared to assist in the various aspects of hand dug well excavation and cleaning.

The Survey Auger Kit is used for groundwater exploration before the start of well-digging operations. The auger is hand operated, normally by two people, to a maximum depth of 15m, but is only useful in soft formations. It also contains a hand-operated test pump for assessing the capacity of the water-bearing strata. The tool kit for well excavation includes digging tools, earth-lifting buckets, safety helmets and mason's tools. Well lining can be undertaken with the Steel Well Liner Kit using curved, corrugated, galvanised sheets or, more slowly, with the Well Mould Kit for making pre-cast concrete rings. The Tripod Kit provides for handling the pre-cast concrete rings and other equipment used in a well. The traditional Dewatering Kit, with a capacity to remove small quantities of water, enables safe, effective and relatively noiseless dewatering to take place during well-digging operations. A new dewatering/desludging kit, using an electric submersible pump has a higher pumping capacity and has been developed specifically for cleaning out wells flooded with mud and other debris.

The First Aid Kit should be seen as an essential component for any well digging operation but training will be needed for the digging crew.

Wherever possible drinking water supplies should be obtained from underground sources, by utilising springs, tube wells or dug wells. Drinking water obtained from such sources usually requires no treatment. The Oxfam/DelAgua Water Testing Kit (Oxfam code FK) is available to ensure the safety of a drinking water supply. However, this kit does not perform tests of chemicals such as arsenic and fluorine and water samples may need to be sent elsewhere for testing.

In many countries large-scale topographical and geological maps are available. Where an

extensive well digging programme is envisaged, these maps would prove very useful. Most governments nowadays can be expected to have much useful information for well construction programmes. The departments to contact initially are those responsible for water, geology, natural resource, agriculture and development planning. In any extensive programme the help and interest of the responsible ministers and officers should be used to the full.

Data normally available in government departments comprise detailed topographical maps (scale 1/50,000 or larger), aerial photos from which those maps were made, and feasibility study reports by the country's departments or by agricultural or civil engineering consultants. However, old maps and reports can still be of use because the geology and topography of a country does not vary except in ways which are obviously visible in the field. If available, aerial photographs and the maps made from them are particularly useful but require skilled interpretation.

It is assumed that, as far as possible, the community will be involved in the planning, development and implementation of its own water supply. Water supply is only part of the public health needs of the community and public health education should form an essential component in the improvement of the community's health and quality of life.

Care of the well should be part of the community's health education. The community will be responsible for the maintenance of the well and maintenance training should be given to chosen people within the community. It is strongly suggested that women play a key role in these activities, as they are the main collectors and users of water whom also play a central role regarding the communities health.

Survey Auger kit

The equipment in the Survey Auger kit is for use in hand-drilling small diameter boreholes, and testing their water yield when looking for sites suitable as locations for hand dug wells. The

equipment will penetrate soft formations for sites for wells not deeper than 15 metres. It is not suitable for hard rocky ground.

The Survey Auger Kit is based on one set of 100mm (4"), and one set of 70mm (3"), diameter augers with necessary drill rods and small items. Casing to suit the larger auger size is included, as well as a 'jolly jumper' test pump and its suction pipes. (It is sometimes possible to hand auger production boreholes. This would require larger augers than have been provided in this survey kit). The Kit is best operated by a trained team which usually comprises one supervisor and four skilled or semi-skilled workers. No more than one person at a time is needed to turn the drill string and auger.

A tripod is not essential and is not included in the Survey Auger kit. However, if a tripod is available the labour of frequent withdrawal of the drilling rods in order to empty the auger will be made easier. The Well Tripod kit (Oxfam code WT6) provides a suitable tripod.

Well lining kits

Two options exist for lining wells, the use of galvanised corrugated steel sheets or concrete rings, which are produced from steel casting moulds. The corrugated steel sheets (Oxfam code WL+P), which can be assembled and quickly placed down wells, are best suited where an immediate response is required, as the kits come ready for use complete with sufficient perforated and non perforated sheets and bolts to line a 5m deep well. These can be particularly useful where infiltration galleries need to be constructed for intakes for surface water treatment systems.

The concrete ring moulds (Oxfam code WM+P) are used for casting concrete rings for more permanent lining of hand dug wells. The moulds will last for many years if treated with care and can be used to produce hundreds of concrete rings. However the collection of suitable materials such as sand and aggregate, the mixing of concrete, casting of the moulds and subsequent curing of the concrete rings all take quite a long time to set up and undertake. Thus this method of lining wells is best suited for medium and longer-term responses. The well

tripod kit (Oxfam code WT6) is also required in order to lower concrete rings into place.

Dewatering pumps

In this manual the term 'dewatering' means the removal of water flowing into, or existing in a well whilst hand digging is taking place below the groundwater level. Traditionally dewatering of dug wells is done by rope and bucket. This is a simple but laborious task with serious limitations, as digging has to stop when the water inflow is too great to be kept under control by the bucket and rope operation. This usually happens before the aquifer has been sufficiently developed to ensure that the dry season inflow will be adequate to meet community needs. Obviously one of the most critical aspects of successful well digging is to ensure that the well is of sufficient depth, and the water inflow is of sufficient quantity to meet the daily water demands throughout the year.

In addition to dewatering by the rope and bucket system, it is possible to utilise some of the hand-operated pumps that are available such as the semi-rotary, diaphragm and piston types. However the dewatering capacity of such hand operated pumps is very limited, as they have to operate within 7 metres of the water level. This 7 metres suction limitation presents serious problems with some types of pumping system. It means that most petrol or diesel driven directly coupled pumps are limited to use on wells of less than 7 metres depth as the pumps must operate at ground level and never be lowered into the well, **where the engine's exhaust fumes will be lethal to any human being working in the well.**

To meet the needs for well dewatering during well construction Oxfam has developed a Dewatering Kit (Oxfam code WPC) that uses an air compressor to supply air to a double diaphragm air powered pump. It is compact, portable, versatile, safe to use and is suitable for both long term and emergency programmes. The compressor also allows the operation of tools such as hammers which may assist well construction operations.

This pump has a maximum capacity of 4.7 litres per second (62 gpm) at low heads with this

compressor. The operating curve is shown below.

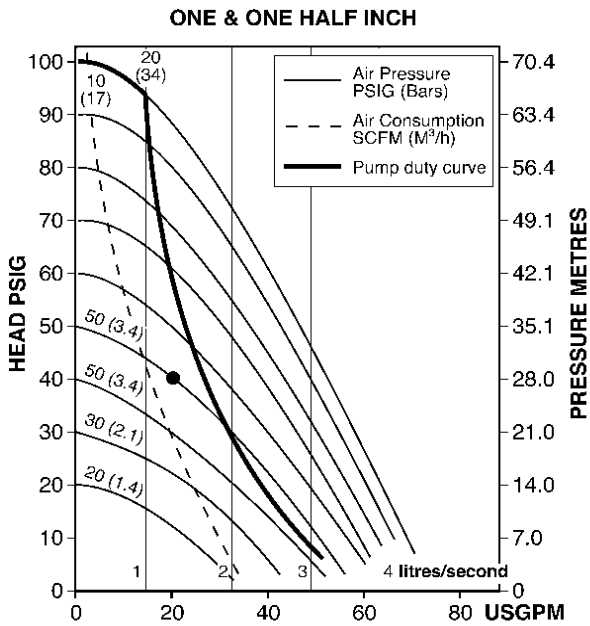

Example: With 20 USGPM (1.3 litres/second) required at 40PSIG (28 metres) discharge pressure 13SCFM (22m³/hr) of air is required at 50 PSIG (35 metres) air pressure.

Dewatering/desludging pump

Recent emergency responses in which existing wells have been flooded and filled with mud and sand and which deny access to these water

sources, have required the use of electric submersible pumps to quickly clean out these wells. These pumps with their high solids/sludge handling capacity can also be used to empty out pit latrines where required. This kit includes an electric generator and pump.

The performance curve for the pump is given below. Though this curve is for pumping water, which is less dense (lower specific gravity) than a mixture of water/soil/sand or sludge from a pit latrine, the characteristics of this pump are such that its performance will only be slightly less than indicated on the curves below. Also included are curves for the pumps operating in series and in parallel (indicated by DSH – double Heron pump).

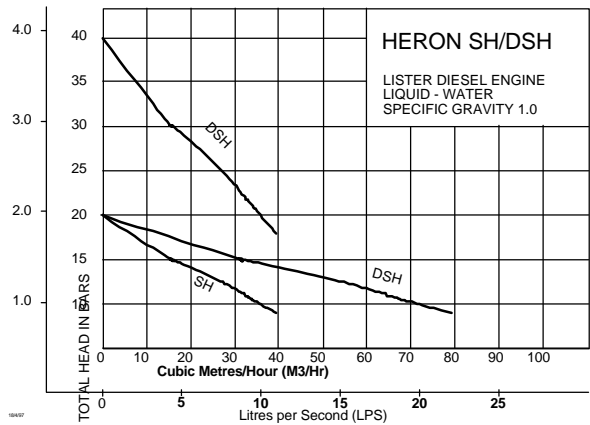

SECTION B – LIST OF KITS AND INSTRUCTIONS FOR USE

This manual explains how to use/erect the following kits (detailed kit lists are provided in section D):

Code	Description
WAS/	Survey Auger Kit
WET/	Tool Kit for Well Excavation
WFA/	Well Digging First Aid Kit
WL+P/	Hand Dug Steel Well Liner (5m of non-perforated + perforated sheets)
WPC/	Dewatering Kit (Mobile Air Pump and Compressor)
WSDP/	Electric dewatering/desludging pump kit with petrol generator
WT6/	Well Tripod Kit

Equipment should be ordered as required, based upon the needs of the programme. It is likely that the well desludging pump will be used for existing well cleaning / pit latrine emptying. The other equipment is intended to support hand-dug well excavation programmes.

The following kits are not commonly used. The specifications have been prepared to facilitate the quick purchase and deployment of these items in the event of any of them being required.

Code	Description
WPCS/	Compressor Service and Overhaul Kit (for WPC/)
WPCT/	Compressor Air Tools Kit (for use with WPC compressor)

Survey Auger kit

Looking for well sites

When looking for well sites it is important to consider all the possibilities for providing water at the intended location.

Initially consult the local people **(1)**, especially the women and find out:

- Where they get their water in the rains and in the dry season.
- Where there is any area which they cannot reach all the year round.
- Where the old men or women think there might be water (near a special kind of tree perhaps).



- Where there are any old or abandoned wells.
- Where water lies after rains and disappears only slowly (an old river bed perhaps).

Do not overlook the possibility that there might be local water diviners who could be called upon for guidance.

Also consider any available alternatives to wells; they might cost less and have other advantages, and would also involve villagers in the work. For instance:

- If local houses have hard roofs, does it rain often enough to enable each house to have its own rainwater tank? (10mm of rain on 1m² of roof gives 10 litres of water).
- Large storage tanks or ponds fed from rainwater catchment areas.
- Spring catchment.

Further consideration and discussion should focus upon areas where it would not be suitable for a well to be dug; such areas include:

- Depressions which become flooded in heavy rains.
- Where flood levels would be higher than the well lining (unless the well is to be designed to suit the site).
- Close to large trees (roots damage wells, branches interfere with drilling; animals shelter in the shade).
- Where the village might expand.
- Where there are overhead or perhaps underground, electricity or telephone cables.
- Near to latrines (see Diagram 2).

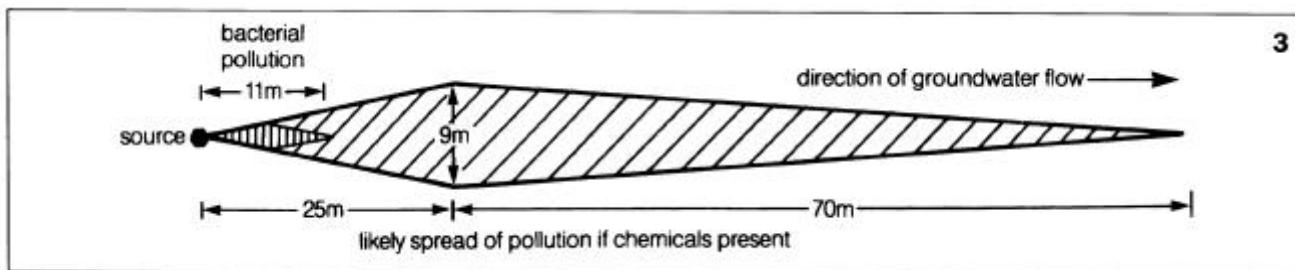
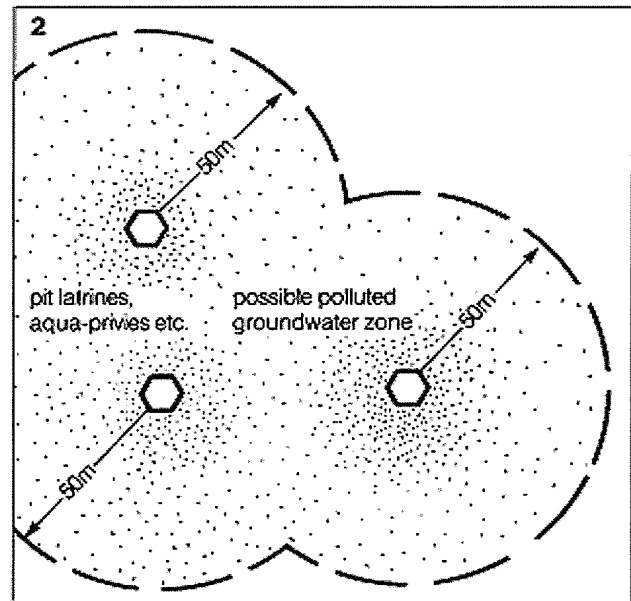

Groundwater and soil pollution may exist for up to 50 metres around any latrine pit, aqua privy, biogas plant, as well as any cattle corral or any ground used by villagers for defecation; these areas should not be used for wells (2). Where an impermeable material lies underneath groundwater and has an appreciable and definite slope, the groundwater itself tends to flow down the slope, carrying pollution with it.

Diagram (3) shows the World Health Organisation's chart of the dispersal of pollution. Where it is confirmed that groundwater at a well site does flow in such a manner, no well should be allowed within 100 metres downstream of the source of pollution

The object of survey boring is to locate an aquifer (a layer of soil or rock able to hold and transmit much water) into which a well may be dug. The good aquifers usually found are of sand, gravel, low clay laterite, or very faulted limestone. Any material containing a large proportion of clay is not likely to be a good aquifer.

In fairly round figures, a well yielding 1000 litres/hour during normal use would give, during 10 hours, enough water to satisfy a demand of 25 litres/day/person for 400 people; 1000 litres/hour would also enable a bucket, full with 5.5 litres, to be drawn out three times/minute. What yield would be considered sufficient, to justify digging a well, would depend entirely upon the need for water – perhaps in general, 500 litres/hour or even less might be considered worthwhile. There is often a safety factor, as a yield from an actual well would (after a few weeks for the well to settle down) usually be considerably greater than the yield shown by the pump testing of a small diameter survey bore.

The boring is best carried out when the groundwater level at the site is at its lowest, usually towards the end of the dry season. If it has to be carried out in other seasons, some estimated allowance should be made when testing its yield for a reduction in the volume of water available in the dry season.

The usual pattern for drilling is to do bores at intervals of 50m and in straight lines 50m apart. When there is nothing in the shape of the land

to suggest where an aquifer might be found, start with a square pattern. If water is found in one, take note of the depth of the water and of the kind of material drilled through (as described later) and compare them with other holes in the pattern – in that way some estimate may be made of the extent of that particular aquifer and an idea of its reliability formed.

Diagrams 4 to 8 indicate a few kinds of landform where aquifers may be found (the vertical scale of the diagrams is highly exaggerated); suggestions for suitable drilling patterns are made.

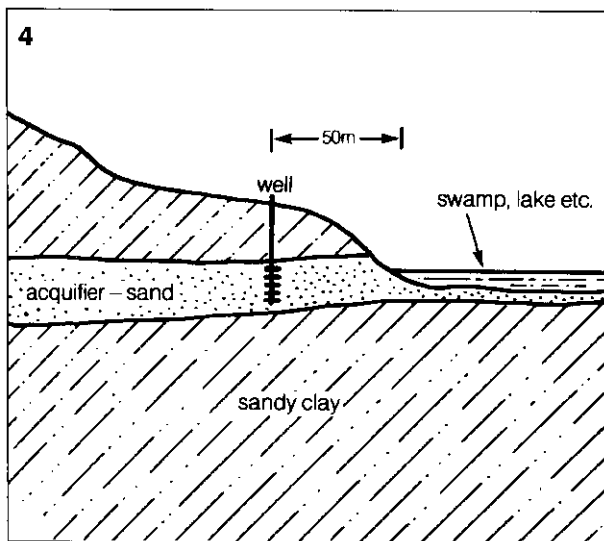

Shallow lakes and swamps which seldom dry out (4) must have a large quantity of incoming water to counteract evaporation. If there is no river or stream to effect this there must be an aquifer feeding it from below water level. Find the aquifer by a line of bores about 50m back from the shore and watch the kind of material that comes up.

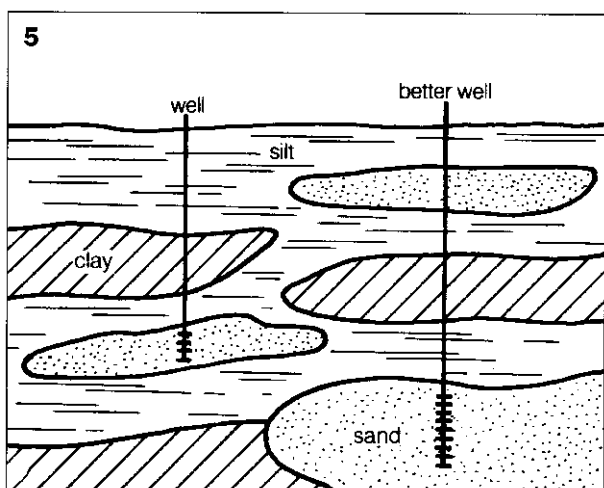

A well into the aquifer at a convenient site should provide a supply as consistent as the water in the lake, or perhaps more so if the well goes deep enough to be below surface water level.

An alluvial plain and a flood plain (5) get higher with each flood which drops silt on it; this has been happening for ages past. During that time the kind of material which was deposited varied from age to age; some were sands and gravels which form good aquifers, often with a very large volume. In trying to find one, run a first line of bores across the valley so as to locate the thickest aquifer material – there may be two separate aquifers one above the other. Then explore sideways from the deepest and from the thickest. Unless the aquifer chosen is very small in volume, or comparatively close to ground level, the water supply to a well should be adequate and lasting.

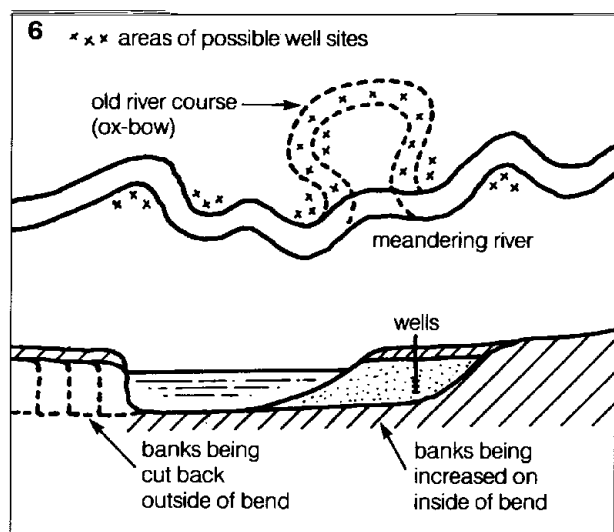

In a meandering river with a slack gradient sand deposits form on the inside of the river bends; sometimes two meanders join and the original river bed then gets left and gradually fills with material (6). Well sites may be found on the inside of existing river bends, within the old riverbed, and on the inside of the bends of the old course. Explore with bores 10m back from the present and old riverbanks and within the old river course. If a well is taken only as deep as the river bed, its water will only last as long as the river is running; if digging can go deeper the possibility of a well being long-lasting is more likely.

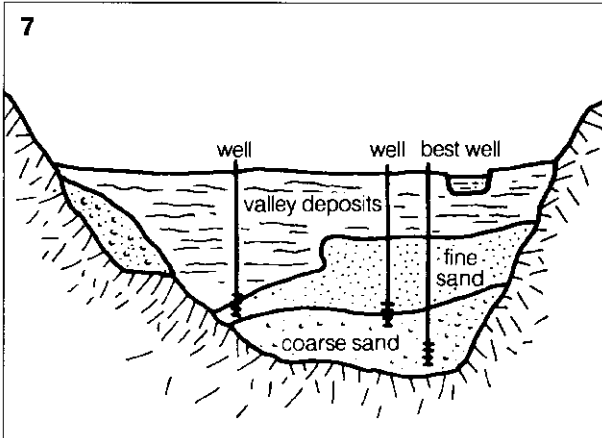

In a valley with a slight slope between sides of hard material (7), it can be expected that the river will have followed roughly the same course as at present. It will have been raised up gradually with the valley floor as deposits from the sides were washed down into it, and aquifers may be found within the deposits at various levels. Run a first line of bores across the valley and then explore sideways from the most likely bores, going as deep as the equipment will permit. If an aquifer is found its extent should be measured by further bores seeking for the same material. A well should be more permanent than the river if the aquifer is considerably lower than the riverbed.

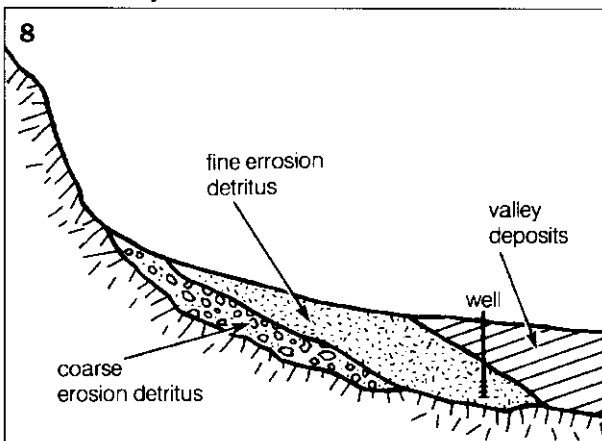

Weathered rock washed down a hill side forms a coarse deposit along its foot, and lighter detritus washes out somewhat further (8). Deposits over the valley gradually cover the detritus and tend to hold water. Run a line of bores square off the line of the hills side starting from where the slope tends to be getting flatter; having found a good bore explore sideways to check the extent of the water. Water in this kind of aquifer is probably run-off from the hillside,

and therefore exploration of the extent of the aquifer, and its yield under test, should be done late in the dry season.

Well design adjacent to surface water sources

Surface water so frequently carries harmful pathogenic material that the public health is best preserved if water for all domestic tasks, not just drinking water, is drawn from wells. To provide wells near permanent surface water is not usually as expensive as digging wells into deep aquifers.

The survey work is not so laborious either, needing only auger borings to check that there is suitable ground for digging at the desired well site, and a line of bores to check that it is possible to dig a trench between the source water and the well site.

It is important that the water reaching the well should have passed through a sand filter, of preferably at least one metre of sand or sandy earth. This will filter out the minute but harmful water-living creatures which act as the vectors of several diseases, and are particularly found in sub-tropical and tropical surface waters. This kind of filtration will not remove harmful bacteria from the water in the way that a slow sand filter does, and it will be necessary to do bacteriological tests, especially for faecal coliform pollution in the well water, from time to time. The use of the Oxfam/DelAgua Water Testing Kit (Oxfam code FK) is recommended for this purpose.

Where there is flooding, all wells should be built up with rings to above the highest expected flood level. All the wells could be made deeper in order to create short-term emergency storage; an extra one-metre depth in a well 1.5m diameter would store about 1700 litres.

Where the soil between the water source and the well will act as an aquifer, no direct connection between them is necessary, and is best not provided. Where no shallow or deep aquifer can be found where the well is needed, a direct connection is required. Many

arrangements can be contrived and the diagrams 9, 10 and 11, show some alternatives.

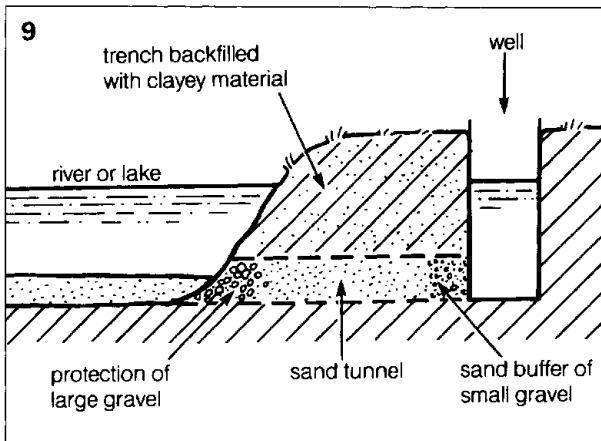

A sand tunnel (9), a trench filled with sand for 500mm depth of 500mm wide and backfilled over with clay material needs to have its entry below the lowest water level, but not necessarily at bed levels, provided the banks were stable and are not on the inside of a river bend.

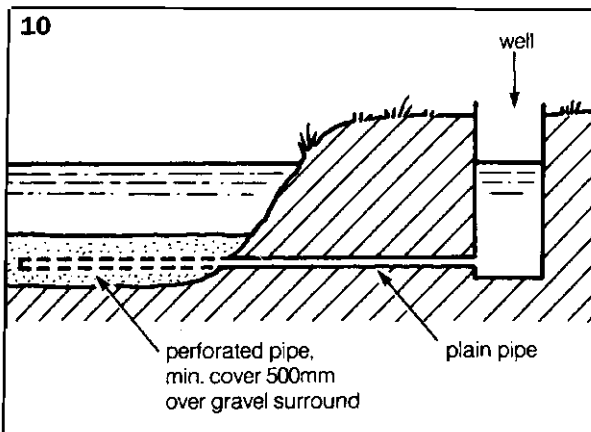

The perforated pipe laid in a deep sand bed (10) is a very suitable intake, and should be laid as deep as possible. A deep bed of sand can hold a large quantity of water even when none is visible on the surface.

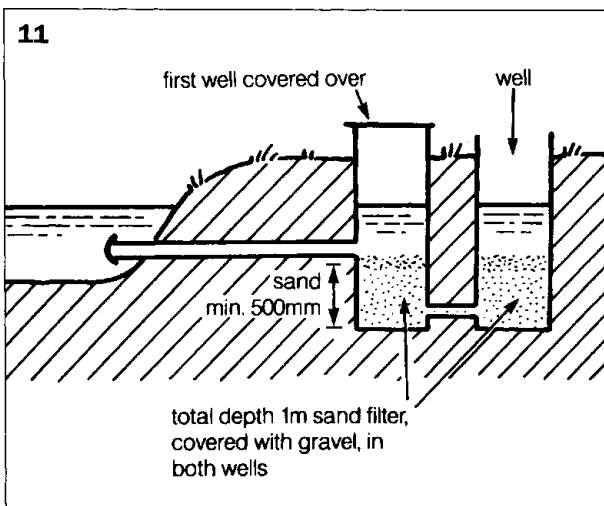

The open pipe intake (11) is the least desirable of those shown but is sometimes useful where the water is deep, or where the banks are unstable. The double well, with the first well covered up, is to enable an adequate sand filter to be provided. The connecting pipe between the two wells, wherever possible, should be located at the bottom of the sand filters.

Some rivers run so low at times or dry up completely, that wells with the direct connection to them are not permanent. To provide sites for permanent wells in those cases, it can sometimes be arranged that an underground dam built right across the valley will provide a reservoir from which wells may be served throughout the whole year, even when the river has dried up. The method is described in reference 2. The design technique and the work are quite simple and do not involve any alteration in the level of the river itself (unlike building on above-ground dam which raises the level of the river itself, for which careful and sound engineering design is needed to deal with such matters as size of the weir, spillway, possible erosion or gulleying, etc, as well as the design of the dam itself).

An underground dam can also be used in a dry valley where there is no adequate low-level aquifer, or to block off an aquifer so that it feeds into a reservoir instead of running away underground. This kind of dam can be of use in blocking off an underground escape aquifer from a swampy area, a large pool, or a small lake, provided the level of the natural above-ground overflow is not raised (unless it has been given proper engineering consideration), and that care is taken not to block off any inflowing aquifer.

Guidelines for equipment use

A description of the various types of auger is given, followed by procedures (rules) for their use.

(The procedures described here apply to survey wells that will provide the data for hand dug wells. In some soils it is possible to hand auger production wells. This will normally require larger equipment than that provided in the WAS kit).

Augers

(See Diagram 12)

A. *Open clay augers* (combination auger)

The points corkscrew into the ground. For use in clay or sandy material which is not too hard or too loose. In loose soil the body must be filled completely to hold the material in the auger when being lifted out of the bore. In clay the body should be filled only about three-quarters to avoid smearing the sides of the bore.

B. *Riverside augers*

The cutting edges of the blades are slightly larger than the barrel, which therefore does not rub against the side of the bore. For use in hard clay, stiff soils, hard sand, and all kinds of deposited material below water level.

C. *Spare blades for riverside augers*

When the cutting edge is worn so that the cut is only slightly greater than the diameter of the body, the old teeth have to be removed (for rebuilding in workshop) and the new ring welded to the body.

D. *Flight augers*

A long spiral auger with a specially hardened point for use in pre-drilling materials such as laterite and decomposed bedrock. It must not be overfilled because the excess material will be dropped and damage the side of the bore. (Some makes of light auger have conical points which are screwed into the body).

E. *Spiral auger*

For pre-drilling in hard materials, the loosened material being brought up with other augers.

F. *Stone auger*

For use in large gravel.

G. *Stone catcher*

Used for twisting round or under large stones; also for 'fishing' for equipment lost down the bore.

H. *Spanner/Catcher*

Used continually to prevent a string of drill rods falling down the bore; a second one is used to tighten joints when adding rods.

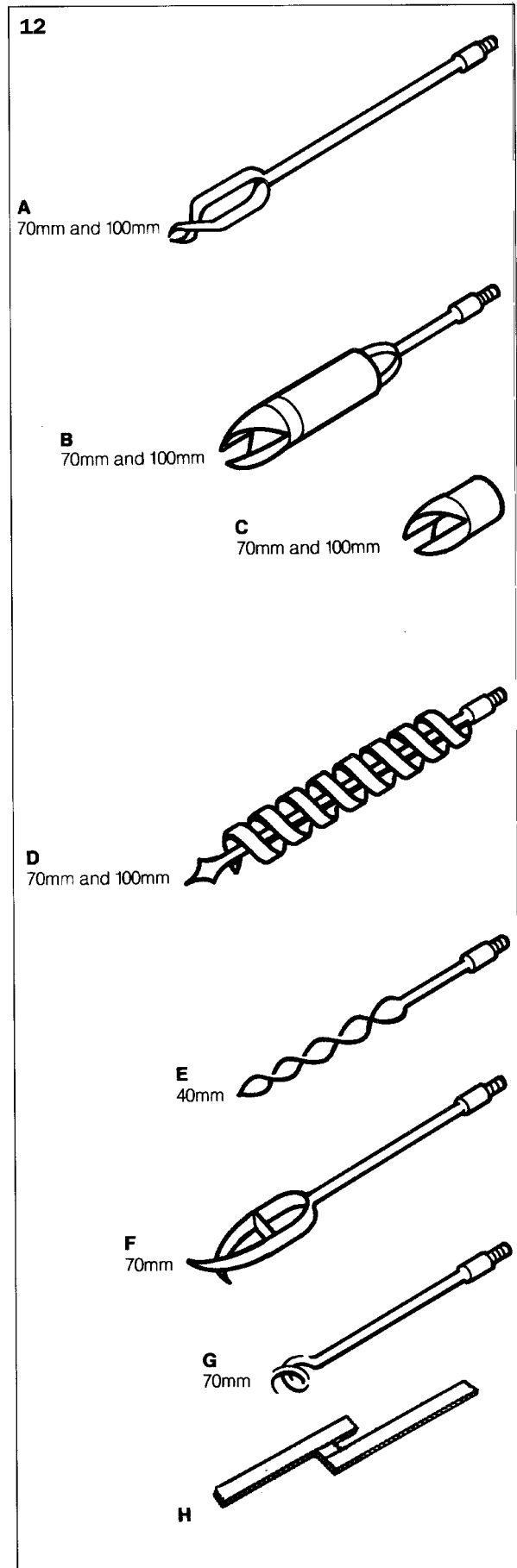

Important rules

1. **All equipment must always be turned CLOCKWISE**, otherwise rods, casings, or risers will become disconnected and drop down the bore and then be difficult or impossible to retrieve. This rule applies when unscrewing anti-clockwise would seem to be the normal process.
2. **Equipment must not be turned by more than one person at a time**, and handles must **NOT** be lengthened if the work is difficult; **damage to the equipment will result otherwise**.
3. **Augers should not be over-filled** because the excess material outside the tool will fall and damage the sides of the bore. An open clay auger needs to be lifted and emptied after about 200mm of digging.
4. **Ensure that equipment is never suspended over a bore without continuous support at ground level**. Spanner/catchers, casing clamps, and adjustable spanners are provided for this purpose.
5. **Boring in or shortly after the rainy season should be avoided if possible**. Ground water levels are usually lowest at the end of the dry season, where there is less likelihood that water level found in a bore may be misleading in indicating the year-round availability.
6. **The drilling site should be kept dry and clean**. In dry weather it is helpful if wooden planks are laid around the position of the borehole itself; in wet weather it is imperative that the top of the borehole should not become trampled in and damaged. From top to bottom the borehole has to be kept clean and free of loose soil and rubbish. A

small bund should be built around the hole to keep out surface water.

7. **Equipment must be kept clean and all cutting edges kept sharp**. In particular thread protectors must always be installed on casings when they are not in use. **All threads must be kept free of oil and grease** so that sand and soil do not adhere and cause wear.

Drilling

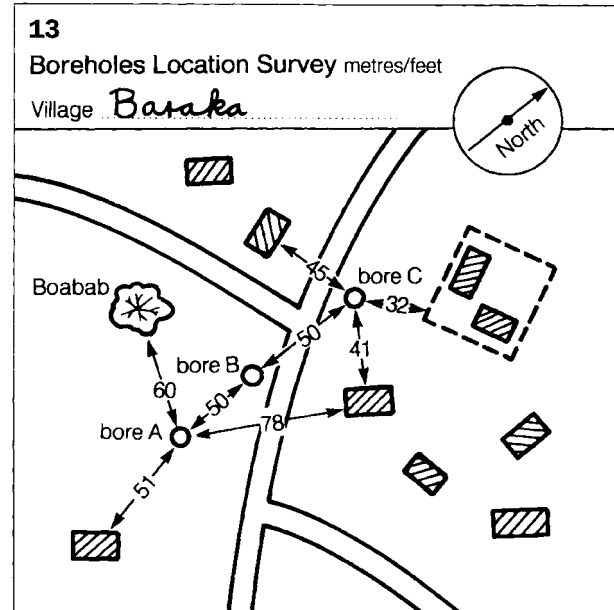

Before starting to drill, peg out the positions of proposed bores so that they may be properly related to each other (for instance, in lines, and 50m apart). Make a sketch map of the area (**13**) and show measurements from two features, or preferably three, so that the bores may be found again if necessary. If there are no local features, make some permanent ones out of whatever material is available.

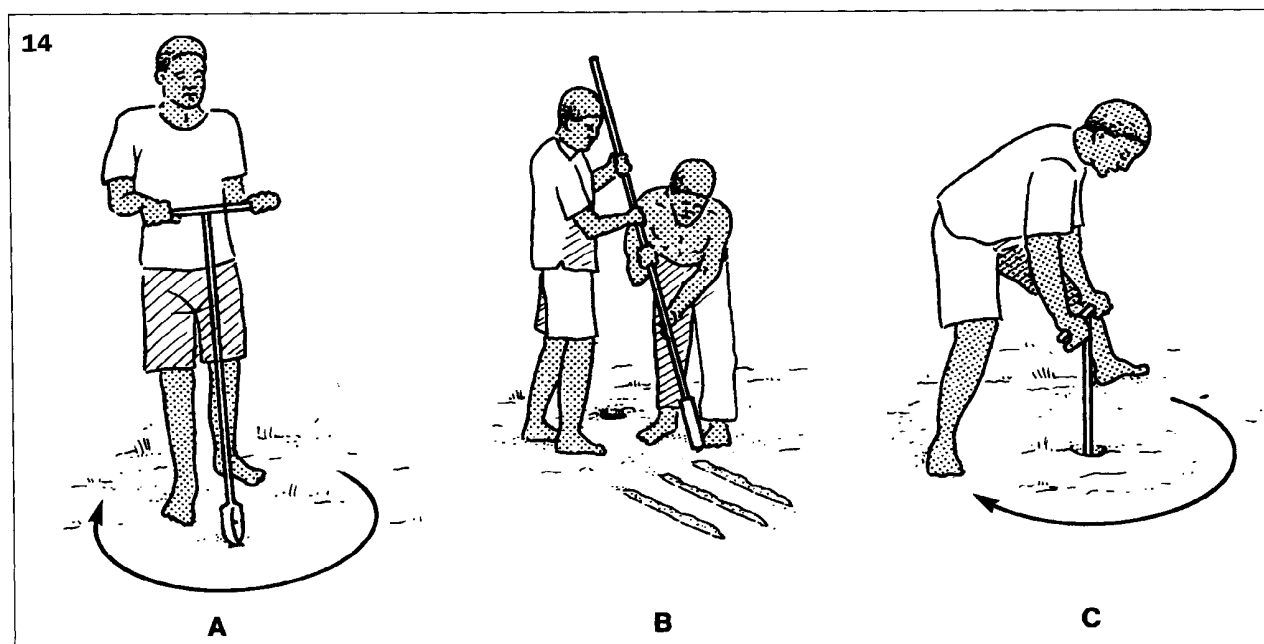

Screw the 100mm open clay auger (**12A**) to the long handle, if the ground is very wet start with the riverside auger (**12B**). If the auger will not bite, dig a small hole until firm material is reached in which it will bite. Turn the handle clockwise only. As soon as the auger is full it must be withdrawn for emptying. When emptying augers, lay out the material in straight lines about 300mm apart from each other (**14B**); make each line about 1m long, so that each line represents material dug out for the length of 1 drill rod. As each metre's line is finished complete the Borehole Drilling Record at the end of this section. When withdrawing an auger the string of rods should be disconnected every 3 rods, otherwise the rods will bend. When the handle gets close to the ground (**14C**) add a rod above the auger, then add the handle and continue drilling. From now onwards either the long or the short rods may be used as convenient, as the bore deepens and extra rods are added. Keep on using the 100mm augers.

Always keep the bore vertical, join rods tightly using both spanner-catchers (**12H**), and always turn the drill string clockwise whether the auger is drilling or is being withdrawn. If rods become

disconnected fish for them with the stone catcher (**12G**).

When the first auger ceases to make progress change to the fight auger (**12D**), or to the spiral auger (**12E**) followed by the flight auger again, and so on, using the stone auger (**12F**) and the stone catcher (**12G**) as necessary. When no progress with 100m augers can be made change to the 70mm augers, and continue until the full depth of 15m has been achieved or until progress becomes impossible even with the spiral auger.

If water has not flooded the bore by the time it is 15m deep, or by the time no progress can be made, complete the drilling record and abandon the site after marking its position.

When water has been reached continue drilling through it until the augers cannot bring up any material because it is too waterlogged and sloppy.

At this point it is necessary to install casing in the hole (**15**) to support its sides whilst using the bailer (**17**) to enable further progress to be made, and a pumping test (**18**) to be arranged.

Casing

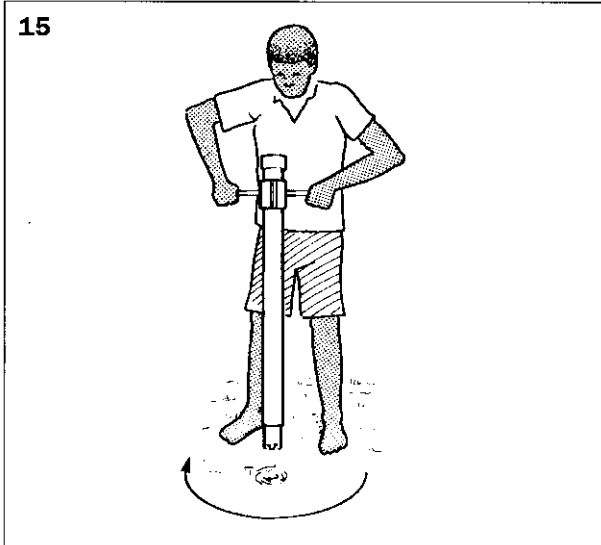

The casing is forced into the bore by one person screwing it in by pressing down on it whilst turning it. The case must always be turned clockwise, never first one way then another, or it will become unscrewed in the bore.

Casing has to be drawn out whenever the work is stopped for a few hours (for instance overnight). It is generally much easier to re-drill a bore which has collapsed than to withdraw casing when the bore has collapsed against it.

Before starting to insert the casing, ream out with 100mm augers whatever part of the bore was drilled with 70mm equipment, then screw the casing shoe (16A) on to the male thread of a slotted casing (16B), fix a clamp (16C) round the other end of the casing and place it in the top of the bore leaving it hanging on the clamp (16C). As the casing goes down the bore add on top two more slotted casings and then sufficient plain casings of the string to reach to the depth drilled and at the same time leave the top of the top casing a little above ground level – the half-length casing may be useful in this. At the finished top screw on the casing head (16D).

If the sides of the bore remain firm and the casing shoe has reached firm material, try to screw the casing into this material so as to steady the casing foot during pumping tests.

If the material entered by the shoe is loose, deeper progress may be possible; throw water

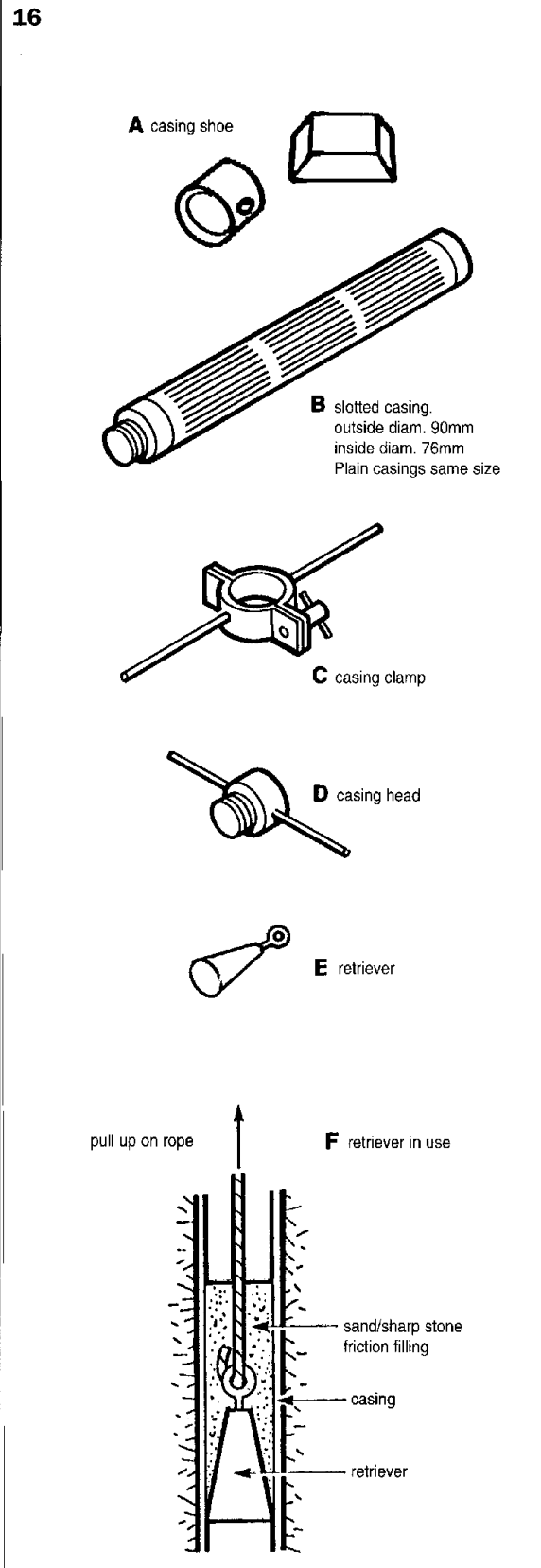

down inside the casing to liquidise the material and, by using the bailer (17), try to deepen the bore.

If the casing has reached semi-liquid or sloppy material, the bailer must be used to take out that material and so enable the casing to be pushed deeper.

If the casing has become unscrewed in the bore use the retriever (16E). Lower it on a string of drilling rods so that it is near the bottom of the casing which is to be recovered and then pour down upon it sharp sand or sharply broken stone until the casing is almost filled (16F). Try not to let the sand fall outside the casing because it might then jam the casing into the sides of the bore. Friction between the sand and the inside of the casing should then enable it to be drawn up and out.

Bailing

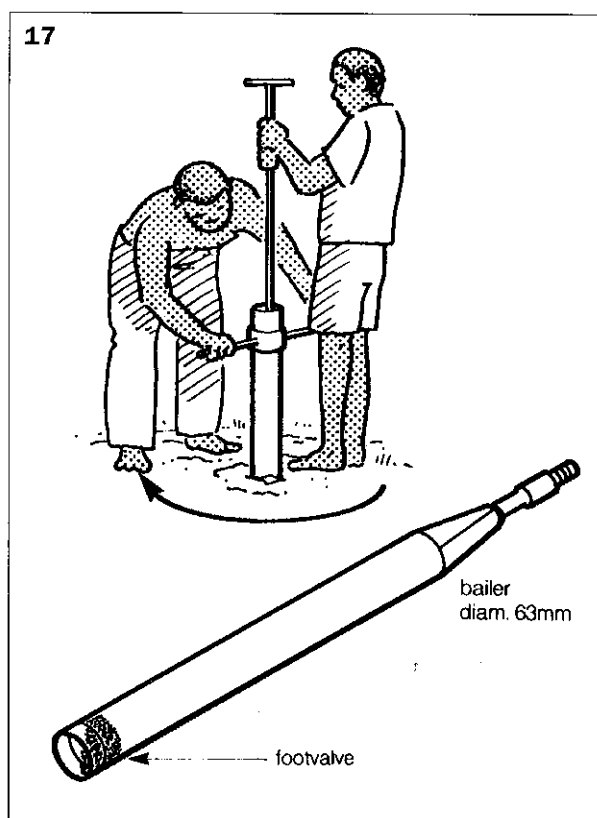

When the bailer is pushed into liquidised material at the bottom of a bore, the material will enter through the bailer's foot valve.

To use the bailer (17), lower it into the bore on a string of drill rods using the spanner/catcher when making all joints, as when drilling. Afterwards one person with sharp and decisive motions should pump the bailer up and down about 1200mm at each stroke while another

person, on every upstroke, should press down strongly on the arms of the casing head whilst giving it a sharp clockwise turning motion. When a suitable rhythmic motion is achieved the casing will gradually sink lower into the bore. When necessary add either the half-length casing or a full length to the top of the string, and continue until further process is not possible.

To reduce any tendency for the walls of the bore to collapse, throw down inside the casing a bucket full of water each time the bailer is withdrawn for emptying. Carefully add emptied material to the lines of other material taken out during drilling (14B).

When the casing has been pushed down as far as possible with the bailer, decide whether there are indications that the bore would be a site for a productive well, if so, run a pumping test.

Pumping Test for Water Yield

A "Jolly Jumper" test pump (18) is the equipment provided; its riser pipes are plastic with steel-screwed joints; a spare foot valve is supplied. Screw the foot valve (18A) on to the bottom of a string of riser pipes as long as the depth of casing in the bore less 0.5m (the half-length of riser pipe may come in useful). All joints must be very tight, and loose pipes must be stopped from falling down the bore. To the top of the string of risers add the pump itself (18B) whose base should sit on the casing head. Attach a flexible hose to the outlet; it will jump up and down with the pump and therefore it has to be held over a container.

If the bore is a good one, at least 75 buckets full of water will need to be carried away for emptying way from the bore – that puts the labour requirement at one person to pump, one person to hold the hose and at least one person to carry buckets away, empty them, and return them to use.

The whole riser string and the pump act as one unit. Pressing the pump body downwards sharply enables water to enter the string through the foot valve and, after the riser string has first been filled, water will be discharged on the up-

stroke powered by the spring. The best test can begin after a few pump strokes to check that the assembly is working properly and to get the underground water to start flowing towards the bore.

There is a special routine for use with this equipment when surveying to find water for hand-dug wells. Divide a pumping test time of one hour into six sessions of ten minutes; measure the water level at the beginning of each session, then pump energetically to try to pump the bore dry, and count the number of full buckets of water emptied away during each successive session. Note the figures on the Borehole Water Pumping Test Record at the end of this section. If the bore runs dry, pump often enough to keep it dry until the end of the session. If the borehole produces well and the pumping can be continuous, pump extra hard during the last 10 minutes of the hour test so as to try to find the bore's greatest possible output. Record the water level **each minute** during the first five minutes after pumping has finished, in order to gain some assessment as to how well the bore recovers to its original water level.

A bore may be considered suitable as a well site if the water pumped out during the test totals 500 to 1000 litres/hour.

The water depth is measured by a 'plover' (18C) which is a hollow tube with one end open attached to a measuring tape. When this is lowered down the bore (beside the test pump risers) it will make a 'plop' noise when it touches the water.

Where there are potential sources of contamination, water quality should be checked using the Oxfam/DelAgua Water Testing Kit (Oxfam Code FK).

Finishing

If the pumping test shows that a suitable site for a well has been found, remove the casing and mark the bore in a permanent and easily visible way (e.g. with a large bough of a tree driven in

deeply and hard), and also check that, if the mark goes missing, the bore can nevertheless be found by reference to the survey marks or positions shown on the site plan (13).

If the test was unsuccessful, remove the casing and lug the top of the bore in such a way that it will not be possible for animals to break their legs in it.

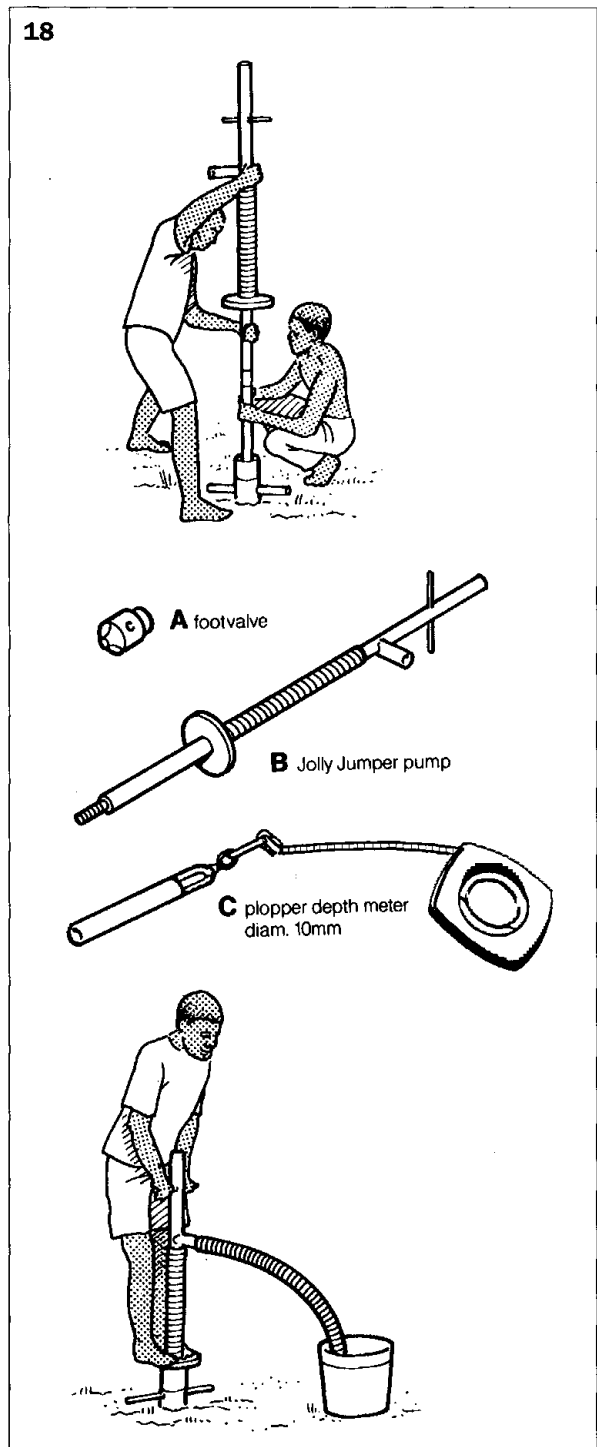

Borehole Drilling Record

Borehole Name _____ Number of Plan _____

Location _____

Fill in each line of this record every time a drill rod is added

Depth Metres	Materials	Kind	Colour	Wetness	Tool
(1 metre drilling equals one drilling rod)	Silt Clay Sand Gravel Laterite other (describe)	Soft Sticky Loose Hard Medium Broken	Black Brown Grey Blue Yellow White Red Orange	Dry Moist Wet Sloppy Water Very hard/ rock	Clay Rivers Flight Spiral Stone Catcher Bailer
Ground					
1					
2					
3					
4					
5					
6					
7					
8					
9					
10					
11					
12					
13					
14					
15					

Notes:

Signed (Supervisor) _____ **Date** _____

Borehole Water Pumping Test Record

Borehole name _____

Location _____

Pumping Tests

Time in minutes	Water level Metres	Buckets filled Number	
Start			
Start + 10			
+ 20			
+ 30			
+ 40			
+ 50			
+ 60			= Total buckets pumped
↓	Continue immediately into Recovery Test Measurements		= Litres capacity of each
			= Total Quantity Pumped
+ 61			
+ 62			
+ 63			
+ 64			
+ 65			

Quality Tests

Colour good/bad **Taste** good/bad

Pumping Test done by _____

Quality Test done by _____

Date _____

Well Lining kits

This section should not be seen as a guide to hand dug well construction, but rather as a guide to using the Oxfam kits. There are many methods of constructing wells and reference should be made to "Hand Dug Wells and their Construction" by S B Watt and W E Wood published by IT Publications. (Reference 1.).

It should not be forgotten that any excavation can be extremely dangerous and lives are at risk. The essential safety issues are covered in Section C of this manual. That section should be carefully studied before commencing digging operations. A first Aid Kit (Oxfam code WFA) is provided and training in its use should be a priority before the digging starts.

Well lining

Two types of lining are covered by the Oxfam Kits.

Hand Dug Steel Well Liner (Oxfam code WL+P/) (19)

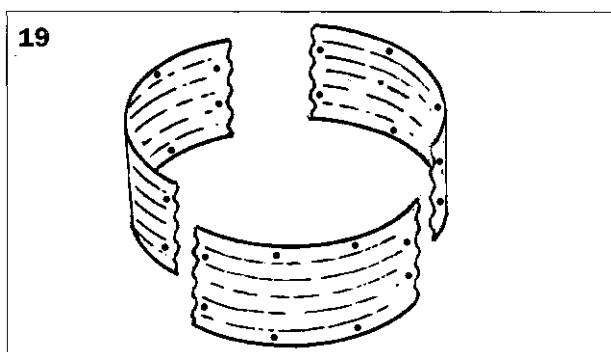

For a very quick, immediate response, emergency water supply hand dug wells can be lined using corrugated steel sheets. The kit provides 2.5 metres of perforated and 2.5 metres of solid (unperforated) lining. This method is especially useful in riverbed wells with sandy formation or where the water table is high, with a maximum depth of about 10-15m.

Three corrugated sheets 600mm deep are bolted together to form each ring 1300mm in diameter. Where the soil is firm the first 1 or 2 rings can be assembled at the surface and lowered into the well. Beyond this depth individual sheets can be added to the higher sheets from inside the well as it is deepened.

Perforated sheets are provided for the lower section of the well. The upper section is not perforated and should be backfilled with clay to prevent ingress of polluted water.

2. Well Mould for non-perforated and perforated concrete rings (Oxfam code WM+P/) provides moulds for forming concrete ring (20).

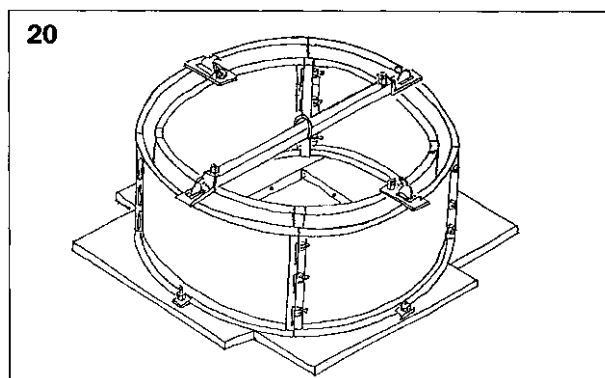

More details are shown on the following pages. The quality of the concrete is very important and reference should be made to Reference 1 if personnel are not familiar with good concreting methods. The question of reinforcement should also be considered. This is especially important if the rings are not cast near the well and need to be transported from the casting yard to the wells. Adequate vibration is essential for producing good quality concrete. The Compressor Air Tools Kit (Oxfam code WPCT) contains vibrators which can be used with the compressor in Oxfam Code WPC.

The moulds have holes which allow for the insertion of steel bars to make perforated rings for the lower section of the well. For the upper rings the holes in the moulds should be plugged with the plastic bungs provided.

The concrete rings made with this equipment each weigh about 630kg. They are therefore difficult to move and lower down the well. A

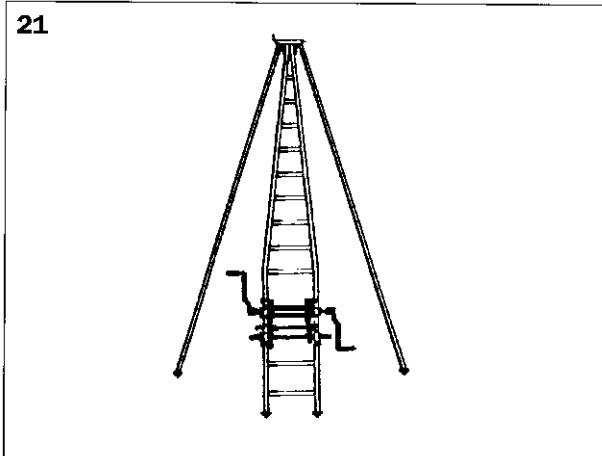

steel tripod has been provided in The Well Tripod Kit (Oxfam code WT6) which allows the rings to be safely lifted and lowered into the well.

This tripod is also useful for lowering workers and other equipment down the well, but a simpler form of support for the pulley provided in the Tool Kit (Oxfam code WET) can be made from local materials. This will make the steel

tripod available for other wells which may be under construction.

It is often possible to excavate a well without supporting the walls and install precast rings, backfilling behind the rings as they are installed. If the soil is in danger of collapsing before the rings can be installed, then some method of temporary support will be required. Alternatively permanent concrete support can be cast against the ground using an internal support. If this support is larger than the precast rings, these can be lowered through the upper section to provide support at lower, more stable levels of the well. These alternatives are not covered by the kits but are often available from local suppliers/manufacturers. Details of the moulds are shown on the following page (22-30) and are also included in the kit.

Oxfam Ring Moulds Assembly instructions

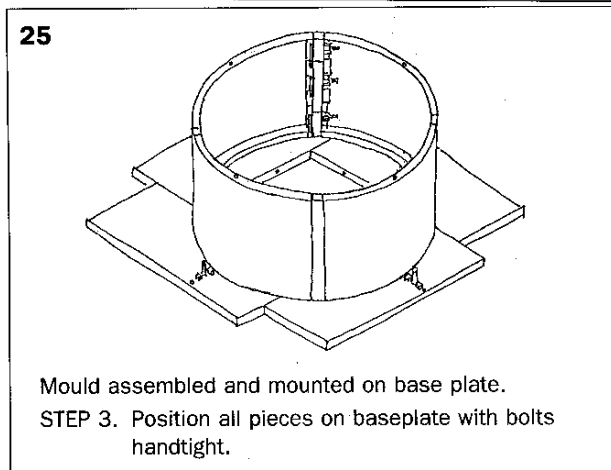
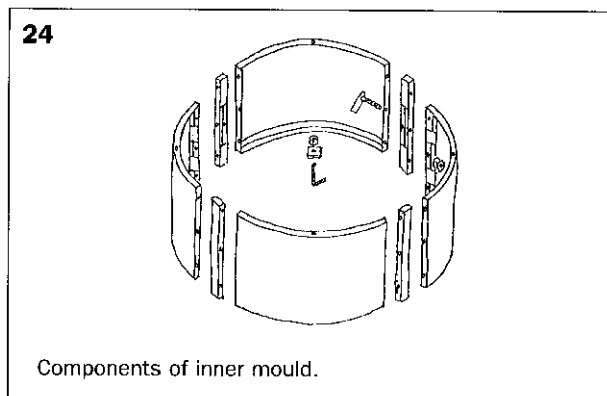
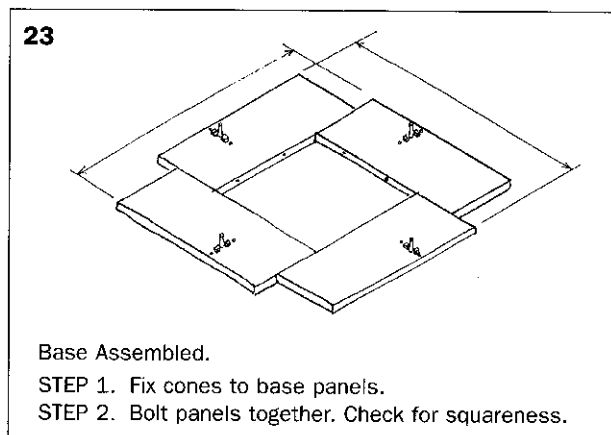
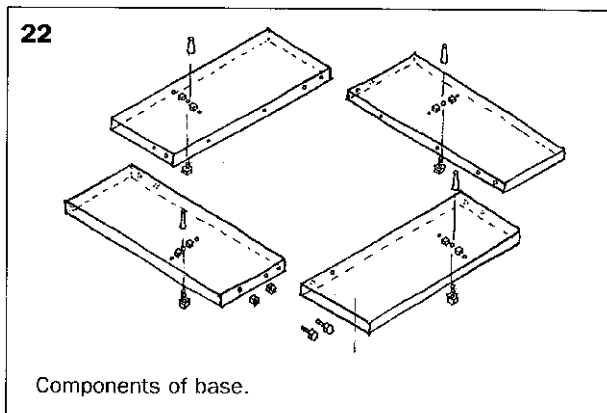

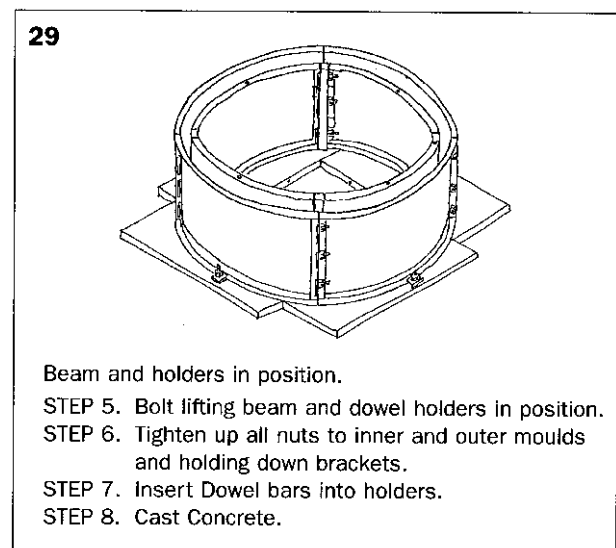
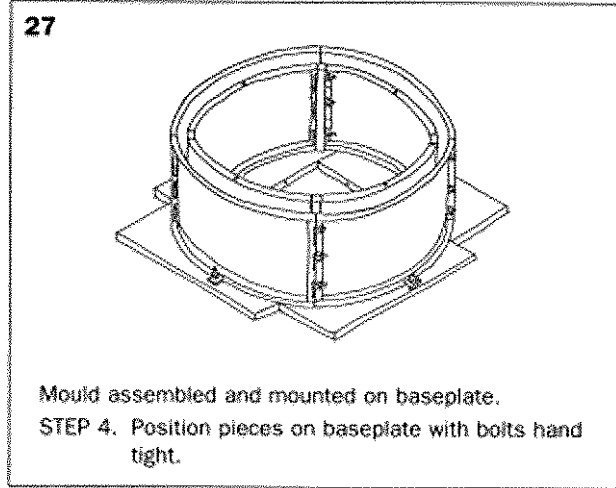
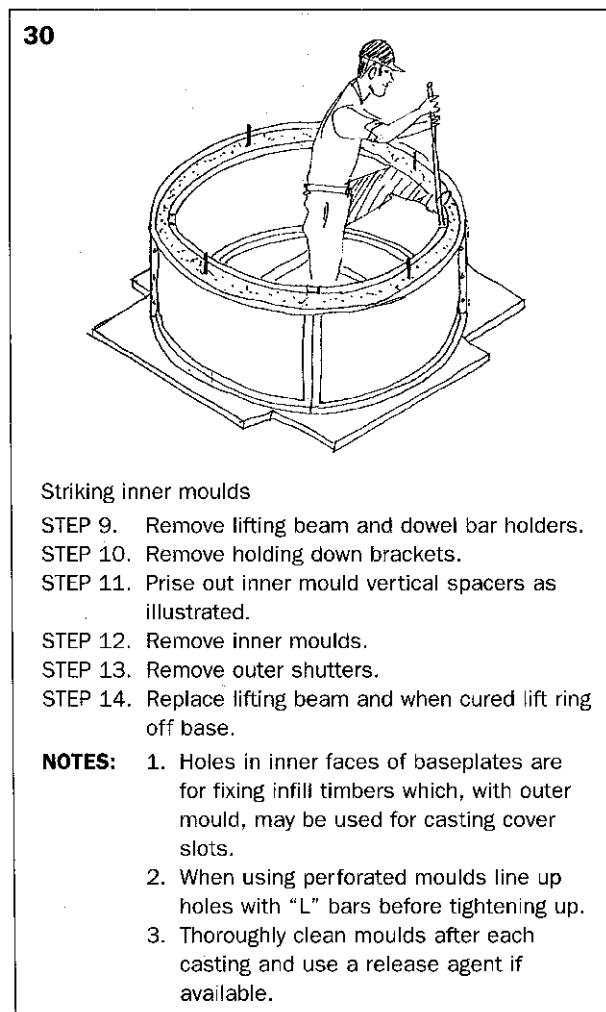
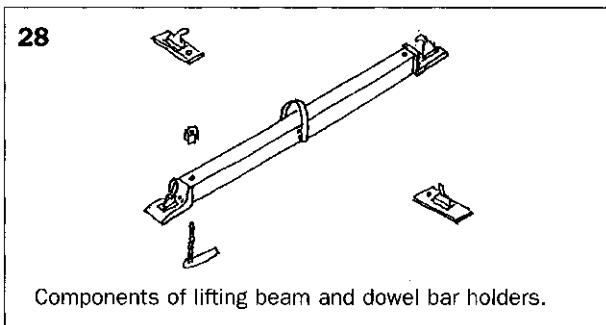
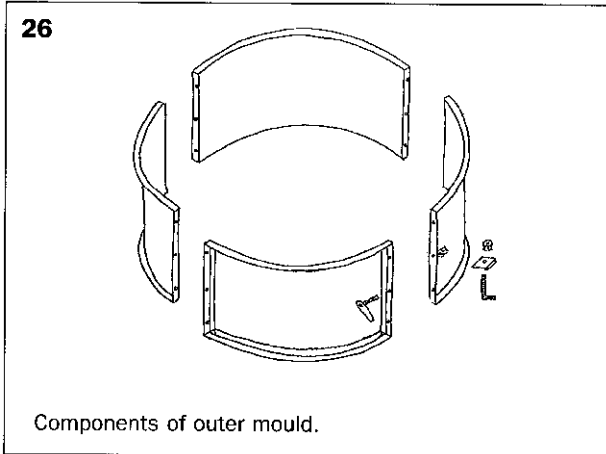

When construction reaches the water level, unless good dewatering equipment (as described in Section C) is to hand, it may be necessary to use the corrugated steel liners described above to complete the well. Alternatively smaller concrete rings can be lowered through the upper section and allowed to sink under their own weight as excavation continues. This method would require another set of moulds for the smaller diameter and a mould for a cutting edge

It is important to excavate well below the standing water level as this level will often be substantially lowered as water is withdrawn, and may lower very significantly if the well has been constructed in the wet season.

Well head & drainage apron construction

It is important that, after the well itself has been constructed, adequate surface works are added to ensure no polluted water drains back into the well and to allow for efficient drawing of clean water, whether by bucket and rope, windlass or handpump. Details of various types of well head can be found in Reference 1. The tools included in the Tool Kit for Well Excavation (Oxfam code WET) will assist with the concrete work required for the well head and apron. The design of the well head should, where possible, take into account local methods of carrying water, with supports at the right level to help with loading water pots onto backs or heads. A drainage channel should lead surplus water/spillage to an animal trough and/or garden.

Water lifting options for hand dug wells

These are:

- 1 – Bucket and rope system
- 2 – Windlass
- 3 – Hand pumps

Bucket and rope system of lifting water from wells is the simplest way of collecting water, and is widely used. The windlass is another development of the rope and bucket system with the advantage that it minimises the contamination of the water in the well caused by the use of different buckets and ropes that easily trail in the dirt. It can be fabricated locally and fitted with rope or chain.

Hand pumps are the best option for lifting water from shallow wells. They provide maximum protection from contamination. Different types of hand pumps are used in different countries, the most common and easily maintained being the Afridev and the simpler Direct Action hand pump for wells less than about 10-12 metres deep.

It is important, where the urgency of the situation allows, to use pumps which have already been used in the particular country and

for which spare parts can be purchased locally. If spare parts are not available and caretakers cannot be trained in maintenance, it is better not to install pumps. In all cases provision should be made for access to the water with ropes and buckets in case of pump breakdown.

Well Dewatering kit

Oxfam Dewatering Kit for well digging operations

A suitable dewatering system should allow for:

1. Safety for the well diggers.
2. Water to be pumped from any reasonable depth.
3. All digging and well improvements to take place at any season of the year.
4. The development of the full potential inflow of groundwater into the well.
5. The ability to measure the sustainable yield from the particular well.

Main advantages of the Kit are:

1. It can be easily transported.
2. The engine is easy to maintain.
3. The engine and the compressor can be placed safely away from the well allowing for noise levels to be kept to a minimum, also to keep dangerous exhaust gases away from the well.
4. The kit can dewater wells of up to 50 metres depth.
5. The pump is light and easy to handle.
6. The pump output can be directly controlled by the well diggers.
7. The pump's air supply can be used to ventilate the well directly in addition to exhausting clean air into the well when in operation.
8. Special air filters are supplied on the compressed air line, to ensure the compressed air used to ventilate the well is safe to breath.
9. Damage to air hoses while digging is not dangerous.
10. If required different size pumps are available to suit different output requirements.
11. The pump can handle silts and small solids and run dry if necessary.

12. The pump is self-priming.
 13. The compressor can also power small air tools such as light hammers, drills and concrete vibrators, described in the previous section. These are available, although not held in Oxfam stock, as the Compressor Air Tools Kit (Oxfam code WPCT).

An electric powered pump of any kind may be used for dewatering, but there is a very small danger that any damage or electrical leakage from power cables or machinery, either in the well or on the ground, which could **cause electrocution and death.** (*The dewatering/desludging pump code WSDP has special safety features incorporated which make it safe to use, but these may not be found on pumps purchased locally.*)

Dewatering Kit Contents

The kit comprises a free standing engine/compressor unit mounted on a two-wheeled trolley. The engine is a Yanmar 10HP Diesel which powers the reciprocating compressor.

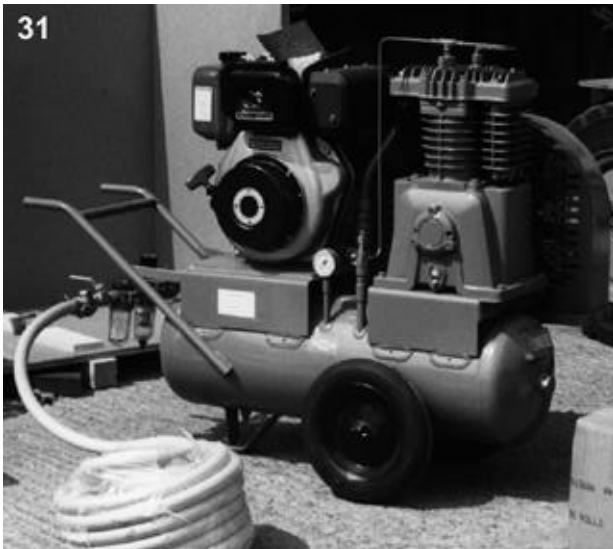

The compressor, producing 14 litres/sec (50m³/hour) at 7 bar (100 psi), powers a 1½" air operated diaphragm pump with oil-less valves.

(NB. Both diesel engines and compressors are subject to significant loss of output at high altitudes, temperature and humidities (6% per 500 metres above sea level. 0.3% per degree

Centigrade above 25°C and 0.4% to 1.6% for each 10% increase in humidity).

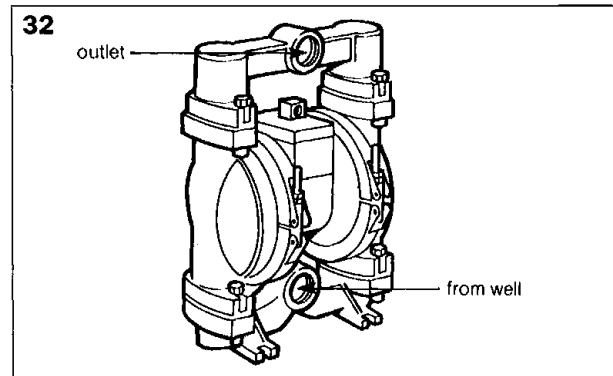

The airline from the compressor to the air-powered pump is fitted with Spirax-Sarco air filters, to provide air safe for breathing by persons involved in well digging operations.

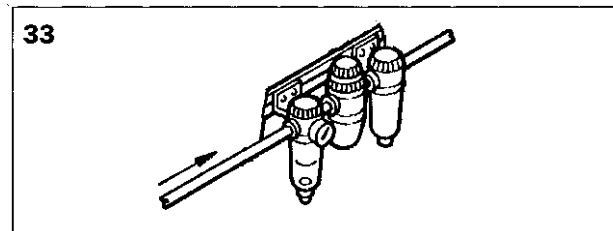

The kit is supplied with all necessary fittings: air lines, couplings, water hoses, and spare parts for 2000 hours running, as well as lubricating oils, tools and operating manuals.

Air filters

When the compressed air provided by the compressor is to be inhaled within the well, it is essential that air filters are installed and used to provide safe air for the well diggers. The air filters provided need to be fixed on to the air hose between the compressor and the air powered water pump.

The main purpose of these filters is to remove dust, water and oil vapours and also odours.

The filters do not remove carbon dioxide or other toxic gases.

These filters will provide continuous ventilation and safe air to breathe for the well diggers while working at the bottom of the well.

In situations where the pump is to be used above ground and the air is not inhaled by the well diggers, the filters need not be connected.

The following filters and regulator, supplied with coupling barrel nipples, are provided in the air flow order:

Filter 1 – IP2

One ½" Spirax Monnier type IP2 international compressed air filter and regulator with manual drain (metal bowl). This filter centrifuges liquids and solids out of the air supply and then passes the air through a nylon mesh element. The filter has a pressure gauge which can be connected to one of two ports provided. Plugs are supplied to cap off unused ports. The airflow direction is indicated by an arrow on the filter body casing. (One packet of spare 3" 25 micron Spirax elements are supplied with the filter).

Filter 2 – IC4D

One ½" Spirax Monnier type IC4 ultraclean compressed air filter.

An extremely fine element capable of removing solids to sub micron levels (99.999%). The filter is fitted with a manual dump valve.

It is recommended that the high efficiency filter is preceded by the No 1 filter (IP2). (Three spare Spirax elements are supplied for this filter).

Filter 3 – IX1

One ½" Spirax Monnier carbon pack type IX1. This filter is regarded as a preferred option rather than essential. This activated carbon element filter is designed to remove hydrocarbon vapours (odour) from the compressed air. It is necessary to fit a high efficiency oil-removing filter immediately upstream of the IX1.

If the filter disk on the IX1 element shows bright red this indicates the presence of liquid oil, check oil removal filter element prior to replacing carbon pack filter element. The IX1 filter removes odour but not carbon monoxide or other toxic gases. (3 No. spare Spirax carbon elements are supplied for this filter).

The air filters are normally mounted on brackets on the trolley so the filters can be held in an

upright position and readily observed, serviced and protected.

Operation

This section covers operational details such as on-site arrangements and operation of the kits components. Safety is covered in detail in Section C.

On-site arrangements

During operations the engine/compressor should be located downwind away from the well digging to reduce noise levels at the point of working, and to avoid the accumulation of exhaust gases in or near the well. It is important to anchor or place chocks (e.g. stones or wood) against the wheel so the unit so that it does not move when the engine is running.

The air hose should be run from the compressor along the ground where it is least likely to be damaged. All kinks and tight loops in the air hose should be avoided and when disconnected the claw couplings should be kept off the ground away from the water, sand, dust, etc.

The air hose is connected to the pump and, if necessary, the pump lowered by a rope attached to the outlet manifold. The weight of the pump should never be carried on the air hose. The pump should be suspended preferably about 2 metres above the bottom of the well. The suction hose hangs from a bend screwed into the inlet manifold.

The advantage of this arrangement is that only the suction hose is in or near the water, which gives maximum freedom of movement to the diggers. The greater the pump height above the well water level, the stronger the suction required by the pump. Therefore for efficient operation and to avoid suction lift problems it is advisable to limit the suction lift where possible to 2m to 3m. However, the pump does have a suction lift capability of about 7m if required and can therefore be mounted on the surface until the well depth exceeds about 6 metres.

The pump can be suspended to one side of the well to allow unimpeded passage of the kibble/bucket being used to remove excavated oil. It is important that the pump remains in a

34

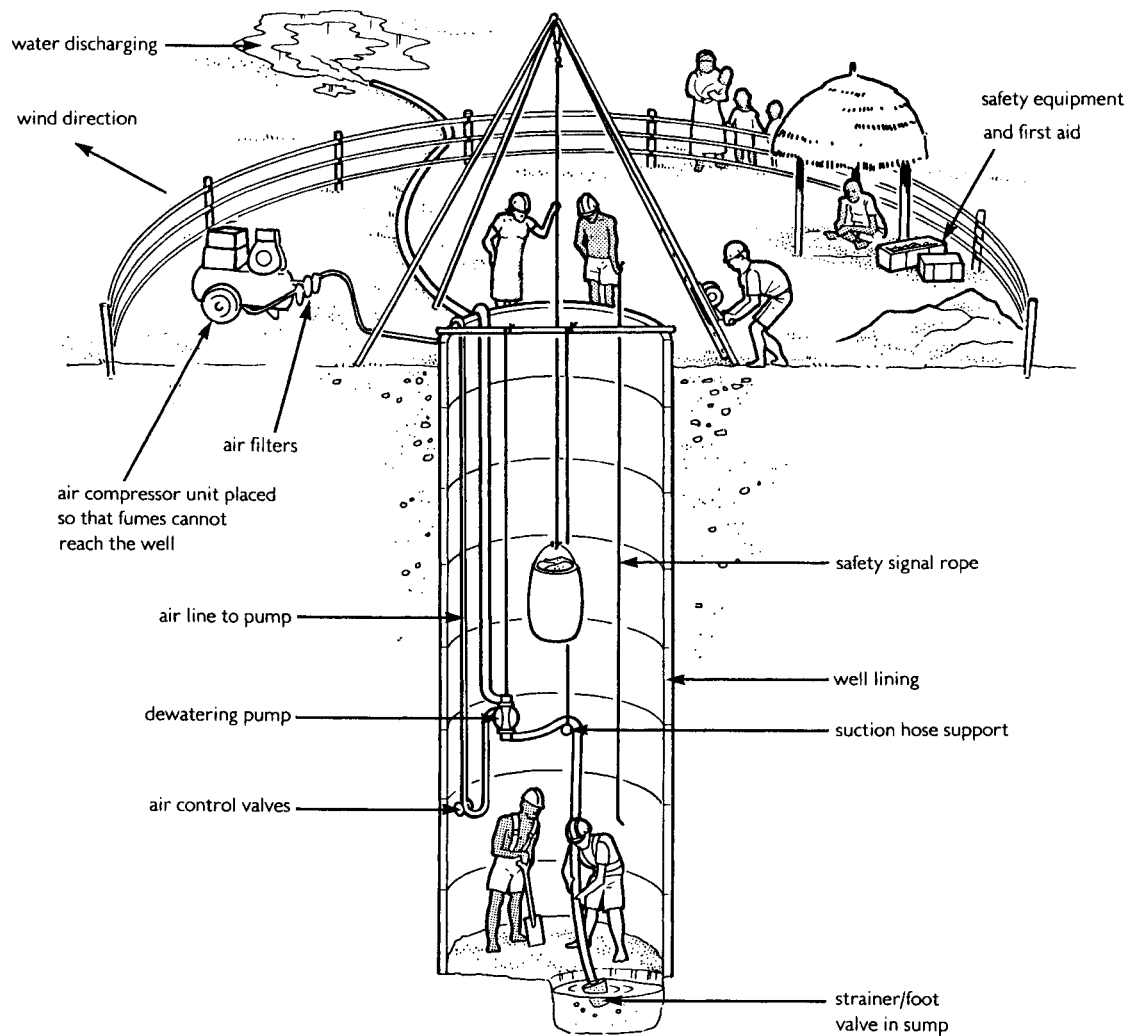

reasonably vertical position whilst running, to ensure efficient operation and seating of the suction and discharge valves. The delivery hose should be run to a convenient point downhill away from the well working area.

Engine Operation

Preparation for starting

Ensure that the engine is filled with suitable lubricating oil to the mouth of the filler port with the engine on the level. Always check oil level before starting. (The sump capacity is 1.65 litres).

Starting the engine (35 & 36)

1. Set the fuel cock at the "O" (open) position.

2. Put the engine speed lever in the "Start" position.

3. Pull out the recoil-starting handle: Pull out the handle to the point where you feel strong resistance and then return it to the initial position.

Push down the decompression level. It will return automatically when the recoil starter is pulled.

Pull out the recoil-starting handle briskly with both hands.

CAUTION!

Do not allow the handle grip to snap back against the engine. Return it gently to prevent damage to the starter.

Do not loosen or readjust either the revolution speed limiting bolt or fuel injection limiting bolt. Performance may be affected.

WARNING! Never use any cold starting aids such as gasoline, paint, ether or other volatile liquids or gas.

Operating your engine

Warm up the engine without load for about 3 minutes.

Stopping your engine (35)

1. Before stopping the engine, move the engine speed lever to low speed and run the engine for about 3 minutes with no load.
2. Return the engine speed lever to the "STOP" position.
3. Set the fuel cock lever to "S" (closed) position.
4. Slowly pull out the recoil handle until pressure is felt (that is to the point in the compression stroke where the intake and exhaust valves are closed) and leave the handle in this position. This prevents rust from forming while the engine is not in use.

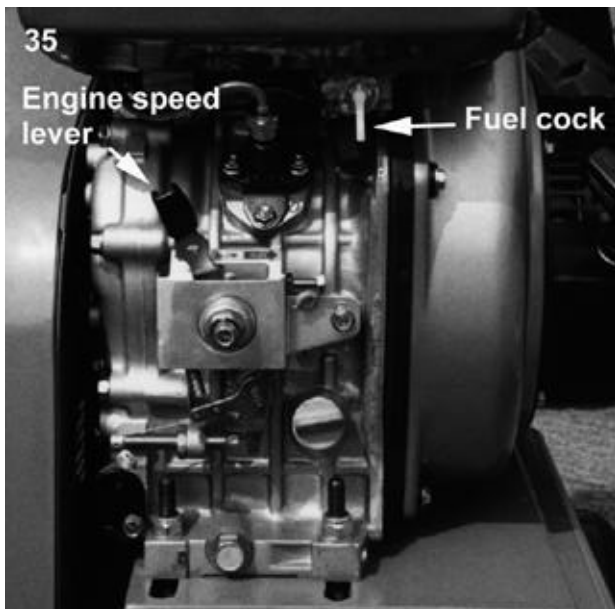

WARNING!

If the engine keeps on running even after the speed lever is replaced at "STOP" position, stop the engine by closing the fuel cock ("S" position) or by loosening the nut of the high-pressure fuel pipe on the pump side.

CAUTION!

When stopping the engine, reduce the load slowly. Do not stop the engine suddenly since it may cause the temperature to rise abnormally.

Do not stop the engine with the compression lever.



Engine Maintenance

see Engine Maintenance Manual for full details.

Compressor Operation

Before starting the compressor it is very important to check the oil levels. Shell Corena 100 is the preferred oil. Maintain the oil level in the middle of the crankcase oil sight glass.

Always stop the compressor to add oil.

Do not fill above the upper line and do not operate the compressor with the oil level below the lower line. Change oil after 1200 hours of operation and every 1,000 hours thereafter, or as required: it may be necessary to change the oil more frequently due to abnormal humidity or contaminated conditions.

WARNING: do not operate the compressor in any area where the atmosphere is contaminated with abrasive dust, i.e. Stonemasons, concrete plants, shot blasting areas etc. Special filters and sealed crankcase breathing systems may be required. Contact the supplier in such cases.

Compressor Maintenance

Daily:

Check and maintain oil level at centreline of sight glass.

Drain air receiver every 8 hours (or 4 hours depending on the humidity)

Check for any unusual noise or vibration.

Weekly:

Clean the air filters. A clogged air filter can seriously affect the efficiency of the compressor and cause overheating and excess oil usage.

Clean all external parts of the compressor and motor. A dirty compressor will cause abnormally high discharge temperature and resulting oil carbonisation on the internal valve components.

Monthly:

Inspect the entire air system for leaks.

Inspect the condition of the oil.

Check the belt drive tension.

Every 3 months or 1000 hours of operation

Change the oil.

Inspect valves Clean the carbon from valves and head.

Check and tighten all nuts, bolts etc.

Check the unloader operation,

Constant speed control pressure system adjustment

Unless otherwise requested the pressure control system is pre-set before dispatch at:

Unloading pressure – 8 bar (117 PSI)

Loading pressure – 7 Bar (103 PSI)

The set pressure can be changed according to the following procedures:

To adjust unloading pressure:

loosen upper locknut
turn pressure-adjusting screw clockwise to increase, anti-clockwise to decrease unloading pressure.

To adjust pressure differential:

loosen lower locknut
turn pressure differential nut clockwise to decrease, anti-clockwise to increase pressure differential.

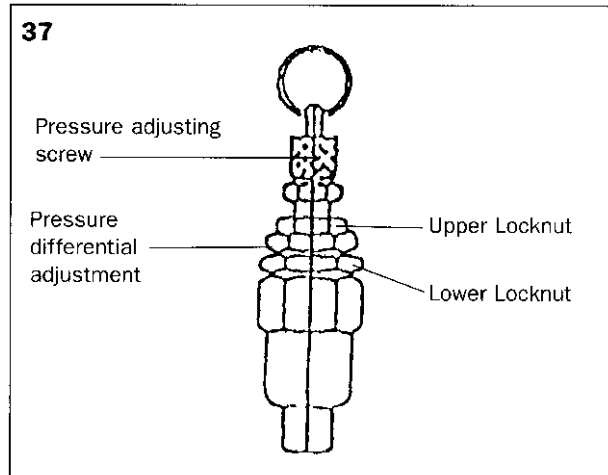

Pump operation

Mount the pump in an upright position. **Do not suspend pump by the outlet pipework.** Secure the pump to reduce disturbance to the connections.

WARNING! NEVER place your hands over or near the pump suction. Powerful suction could cause serious injury. The pump leaves the factory having been flushed with an oil based rust inhibitor – therefore do not allow water from the pump to be drunk until it has been thoroughly flushed through.

When the compressed air supply is turned on, the pump will commence operation and will continue automatically until the supply is shut off. Reduce the airflow to the minimum required for the water-pumping rate. In some circumstances the pump can stall. If this happens it is possible to restart by pushing the air valve pin (manual shifter) by hand or by closing the air supply and re-opening.

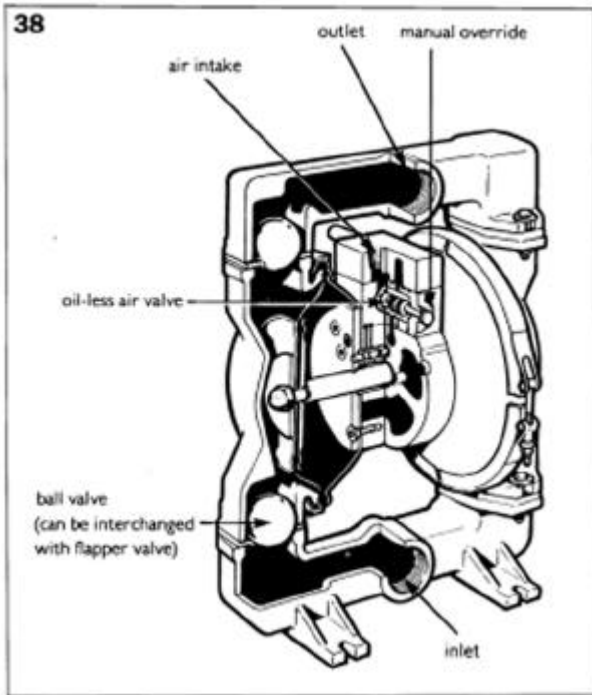

Reasons for failure in pumping are:

✘ Lack of prime due to air getting into the suction hose. Check for any leaks at joints or in the hose.

✘ Blocked diaphragm chamber which must be dismantled to free.

Unbalanced pumping and air exhausted from the discharge hose are caused by:

✘ Diaphragm damaged, or leakage past loose nut on pump shaft. If the diaphragm is damaged it must be replaced.

The rate of pumping can be varied over the complete range from zero to maximum discharge possible for a particular air supply, by adjusting either the airflow or the pressure of the compressed air or a combination of both.

The airflow and pressure are controllable and adjustable at the compressor outlet, at the filter

regulator, and at the control valve to the water pump.

The pump should not be used in a submerged position in case silt is drawn into the air valve piston and causes damage.

Failure to ensure 100% sealability of the suction connection could adversely affect performance.

Drain the pump thoroughly before storing. Invert the pump to allow water to drain from the non-return valves.

Pump Maintenance

See Pump Maintenance Manual for details.

Disconnect air supply before dismantling any portion of the pump.

Other Operational Information

Each Dewatering Kit includes:

Operating and Maintenance Instructions and this Manual. Within the operating and maintenance instructions there is a section covering the Air filter servicing – please refer to this for air filter servicing.

In extreme, dusty, conditions more frequent changes of filter elements and oil, than those given in the manuals, are essential. The quality of fuel is also important, and where transported in barrels checks should be made for water, dirt and any other contaminants. The fuel should be filtered if suspect, and it is important not to run the fuel tank dry, not only because of the necessity of clearing air locks but also because settled matter in the tank can be drawn in to the fuel system.

Trouble shooting guide

NOTE: Check all solutions before dismantling the pump

PROBLEM	CAUSE	SOLUTION
Pump will not start	Air valve assembly malfunction/seizure	Check carrier for freedom of movement – Clean, oil and replace
	Obstructed fluid line	Clean line or increase line size
	Obstructed diaphragm chamber	Remove obstruction
	Diaphragm failure causing fluid and excessive air to be expelled through the exhaust	Replace diaphragm
	Diaphragm seal failure	Replace shaft seals
	Air valve system malfunction	Check all seals in valve chest assembly
	Air connected to exhaust	Re-connect to air inlet
Erratic flow	Diaphragm failure on one side	Replace diaphragm
	Valve ball not seating	Check and remove obstruction
	Suction leakage	Check and correct
	Diaphragm failure or partial failure causing fluid and excessive air to be expelled through the exhaust	Replace diaphragm
	Diaphragm seal failure	Replace shaft seals
	Air valve system malfunction	Check all seals in valve chest assembly
Pump strokes but will not discharge	Excessive suction lift	Shorten suction line
	Suction line leakage	Check and correct
	Valve ball not seating correctly or damaged	Check and remove obstruction/replace
	Suction line or strainer clogged	Clear
	Diaphragm failure	Replace diaphragm
Fluid discharged from exhaust	Diaphragm failure	Replace diaphragm
	Loose front plate	Re-torque to manual specification
Intermittent stroke rate	Over lubrication	Shutdown pump. Remove air connection into pump and introduce a small quantity of degreasing agent into air valve and replace line. Run pump until clear
	Diaphragm shaft seal failure	Replace seals
	Air valve system malfunction	Check all seals in valve chest assembly
	Valve ball not seating/partially obstructed	Clear obstruction

Well dewatering/desludging kit

This kit consists of an electric submersible pump equipped with a Heron screw centrifugal pump. This type of pump has been selected as it has a high solids handling efficiency and its performance in handling such matter is only slightly less than compared to handling clean water. This makes it particularly suitable for dewatering open wells filled with sand and soil after floods and hurricanes. The Heron pump can also be used for desludging pit latrines. The maximum head of the Heron pump is 20m; this package is designed to dewater wells at around a depth of 15m. If higher heads are required then two WSDPs' can be coupled together to give a maximum head of 40m. (7m³/hr at 35m head).



A base plate is provided on the bottom of the pump to prevent the legs of the pump sinking into the mud causing the impeller to try and drill itself downwards, which results in the pump becoming clogged up. If the base plate is not present, either suspend the pump just above the muddy bottom, turn it on its side or put it in a large perforated bucket.

These pumps should not be run without water in the pump chamber or the seals will burn out after 1-2 minutes. So where pumps are run in series, the second pump does not need to be submersed, but the pump submersed in water should be started first before switching on the second pump.

These desludging kits have 2 safety features to considerably reduce the chances of an accident

occurring when people are working down a well. The first 20m of cable running from the pump body are protected by an outer sheath of hydraulic hose, which serves to prevent the cable being cut with a digging or other tool during excavation. The generator itself has an in-built RCD earth leakage device (as per UK building regulations) which cuts off power within 30 milliseconds of a leak detection, e.g. caused by cable being damaged. **However it should be noted that other generators/pumps, may not have this cutout device and cable protection installed, thus exposing operators to risk if working down a well during pumping operations. If locally procured pumps or generators without these safety measures are used, it is recommended that they are only used to desludge wells and pits where no one is working inside them when the pump is running.**

Instructions for coupling 2 WSDP together in series (40):

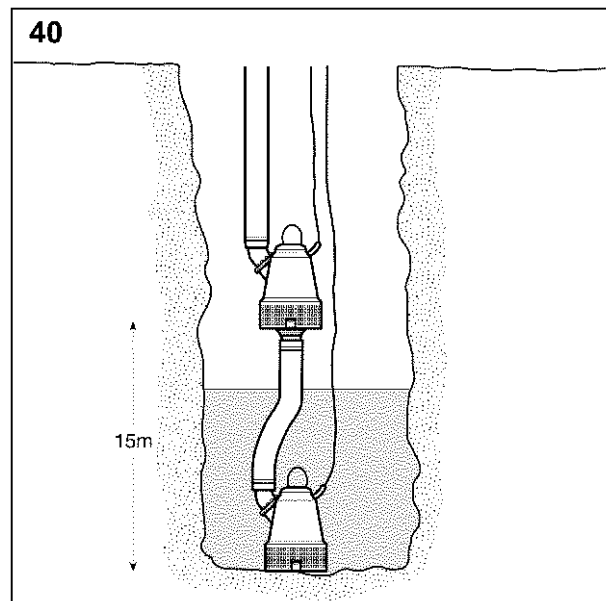

1. Using the wire cable and cleats provided the lower pump should be suspended, by a loop around the handle, at the bottom of the well. The second pump should be suspended some 15m above the first pump. Two pumps on one cable is very heavy. A pulley is provided which should be attached to a tripod/pole across the well/a tree or a vehicle. Great care should be taken when lowering the pumps and gloves should be worn.

2. Remove the base plate on the second pump and connect the layflat distribution hose from the first pump into the bottom of the second pump, the kit contains a male connector for this.
3. The electrical extension lead should be attached to the cable from the first pump. The connector is splash proof but not waterproof so avoid submerging this connection under water.

CODE PR2-ALBS Light Weight Self-Priming Pump Powered by an Air Cooled Petrol Engine

GENERAL: The Kestrel engine driven pump is, of glass reinforced polycarbonate (GRP) construction with a semi open clog resistant impeller and a Buna N (Nitrile rubber) mechanical seal with carbon/ceramic or carbon/carbide faces, designed for general purpose pumping and dewatering. It is compatible with most non-flammable liquids with temperatures between 4 – 49°C. and will handle solids in suspension upto 11mm.

Routine maintenance schedule

The Briggs and Stratton engine uses a high quality detergent oil, classified for service SE/SF/SG, specifically a SAE 30 oil. Air-cooled engines run hotter than automotive engines, and the use of a multi-viscosity (grade) oil will result in high oil consumption and possible engine damage. If the use of multi-grade oils is necessary, the oil levels should be checked more regularly.

ALWAYS DISCONNECT BATTERY CABLES AND SPARK PLUG WIRE FROM SPARK PLUG BEFORE PERFORMING ANY MAINTENANCE OPERATION REQUIRING DISASSEMBLY OF THE PUMP.

Daily	<ol style="list-style-type: none"> 1. With engine stopped, check level and condition of engine oil. 2. Remove chaff and debris from cylinder head fins and recoil starter finger guard. 3. Check fuel supply. 4. Check clack valve on pump inlet has free movement. 5. Drain water from pump, flush and fill with clean water. NB: If there is any chance of frost, water should be drained immediately after use. 6. Check and clean suction hose filter/foot valve if fitted.
50 hours	<ol style="list-style-type: none"> 7. Replace or clean sparking plug. 8. Clean air cleaner elements (2 No). 9. Check governor linkage, spring and controls, clean and lubricate as necessary. 10. Drain lubricating oil, refill with correct type and grade of oil. 11. Check for leaks, tightening nuts and fittings as necessary.
125 hours	<ol style="list-style-type: none"> 12. Change air cleaner elements. 13. Carbon deposits should be removed from top of cylinder, cylinder head, top of piston and around valves.

Comprehensive information concerning Routine Maintenance can be found in the Operating Instructions and/or Owner's Manual supplied with each pumpset.

The routine servicing and maintenance periods given are based on average operating conditions. Under very dusty conditions air cleaners, lubricating oil and fuel filters will require more frequent attention. Decarbonising may be required more frequently when engines are running on light loads for long periods.

SECTION C - SAFETY INFORMATION

Introduction

This safety section of the well digging manual outlines essential precautions to be observed during construction and commissioning of the well.

Dangers and safety measures for hand dug wells and similar engineering projects

Digging holes in the ground whether for wells, quarrying, foundations or any other purpose, is a potentially dangerous operation. In geographical areas, where well digging is a local skill, the dangers arise from familiarity; while in other areas it is the lack of knowledge which presents serious risks.

It is of paramount importance that all reasonable precautions are taken to ensure that what is intended to be a life saving project (the provision of good water supplies), does not cause tragic loss of life or limb through ignorance or carelessness during the construction or maintenance operations.

The danger areas shown in figure 34, should be noted and continually brought to the attention of workers and to the local population, during the construction of a well. Equally important, especially for a community that has not previously had the use of a well, are the safety precautions to be observed during the life of the well and particularly during maintenance, cleaning or deepening operations.

Before starting well construction

The people/supervisor responsible for the well digging operations should answer the following questions:

- Is your equipment adequate and well maintained?
- Is your team experienced in well digging? Are they aware of the dangers and risks?
- Have they all been provided with safety helmets, and are they willing to wear them?
- Are they trained in First Aid, resuscitation techniques, and use of safety lamps?
- Have you agreed the signalling system and made sure everyone is familiar with it?
- Is your dewatering pump safe? If you expect to dewater below 7 metres from ground level, make sure you have an air driven pump (or electric submersible with safety features).
- Never lower an internal combustion engine into a well.
- Do you have sufficient, appropriate materials to support the sides of the excavation?
- Is all your safety equipment ready for use? (See equipment list).
- Is the community aware of the dangers existing around the well and equipment, i.e. children and animals falling down the well, etc?
- Have you fenced off the working area?

During well construction

- Don't take risks!
- Clear the area for at least 2 metres all around the well and keep it clear of people, animals, materials, equipment (especially fuel/oil containers).
- Provide a kerb all round the well made of timber or rock if possible, to prevent stones, tools etc. being kicked into the well.
- Do not construct a well less than 750mm in diameter if people have to enter the hole, (i.e. excluding boreholes drilled/augured from the surface).
- Watch for soil cracks at the surface and in the walls of the excavation, also for incoming water or loosening soil. Support the sides of the hole as necessary so that the walls do not collapse on top of the diggers.
- Keep a reliable person at the top of the well at all times when people are in the well. Only one/two trained, reliable people

should be in charge of the winch operation. Keep noise levels down so that what is going on in the well can be heard.

- Keep the well ventilated.
- Make sure everyone in the well can be seen from the surface, and can get out quickly. Lower and raise workers with a safe seat.
- Tools should be lowered into the well, not carried by hand, or they might drop on someone's head.
- Do not lower well rings or other heavy items with anyone below. Get people out first!
- Never look down the hole, or climb down, without your helmet chin strap fastened!
- Arrange some shade for diggers to rest in when they return to the surface.

Within the well

- Secure ladders.
- No smoking.
- No matches.
- No naked lights (except for testing the air).
- No nylon ropes (static electricity causes sparks which can cause explosions if there is methane about).
- Never load a bucket/kibble above its rim and loose material.
- Always provide a latrine bucket for lowering into the well when called for as soon as the well is too deep for workers to exist to urinate. Make sure it is regularly emptied away from the excavation.
- When you hit rock will you need explosives? Make sure you get expert help. Explosives must be stored in an approved magazine (special store room for explosives) and used with great care. Don't take risks!
- Never use an internal combustion engine down the well when you hit water and need to pump it out to continue digging, or to test the well's capacity. Many people have lost their lives breathing engine fumes in wells.

After well construction

General care of the well should involve the community as a whole, while the well maintenance should be the responsibility of chosen people. Women must play a key role since they are the main water collectors and users. Well-maintenance training should outline the importance of:

- Keeping well fencing in good condition so that animals have no access.
- Keeping well parapet and cover (if provided) in sound condition.
- Keeping rope, windlass (if fitted), and buckets in good condition – to be replaced when necessary.

Also, before entry into the well, whether for maintenance, cleaning, deepening or simply to retrieve fallen objects:

- Test air with lighted candle, lowered to the bottom.
Do not enter if candle is extinguished.
Clear air by lowering and raising a brush of twigs/branches almost the same diameter as the well.
Retest with candle.
- Make sure ladders are in sound condition and are securely fastened.
- Ensure people entering wells are wearing safety helmets and have rope firmly attached to them, with enough people at the surface to haul them to safety if problems arise.
- Agree a signalling system for raising/lowering equipment and personnel.
- If pumping is necessary to lower the water level for cleaning or deepening, make sure that no internal combustion engine is lowered into the well, and that any exhaust fumes from such engines on the surface are directed well away from the well opening.

Summary of Dangers and Safety in Hand Dug Well and Similar Engineering Projects

The Well Safety Display Notice is available from the Public Health Engineering Team, as A4/A3 size and laminated, in English, Spanish, French, Portuguese and Arabic. It should preferably be translated into the local language and prominently displayed.

DANGERS

1. *Lack of knowledgeable supervision.*
2. *Careless workers and work methods.*
3. *Interference by onlookers or animals.*
4. *Faulty equipment: ladders, ropes, supporters, tripods, hooks, buckets.*
5. *Falling materials.*
6. *Risk of collapsing soil.*
7. *Poisonous gases from explosives, petrol/diesel engines, soil methane.*
8. *Problems of incoming water.*
9. *Problems of excessive dust.*
10. *Pollution of well by human excreta, fuels or lubricating oils.*

ESSENTIAL SAFETY MEASURES

11. *All hand dug wells and such works must be planned and supervised by competent staff.*
12. *There must be agreed signalling arrangements and adequate supervision, control and attendance at the well head at all times* when digging is taking place. No persons should dig alone. Safe and easy access to the well should be provided.
13. *Safe and appropriate well construction techniques must be used*, particularly temporary soil support or permanent well lining during excavation. The hole should be protected when digging is in progress or made safe when workers are not on site to prevent people, animals or materials falling in.
14. *Good and regularly checked equipment should be used* (ropes, ladders, lifting gear, tripods, skips etc). Good quality tools and tool handles for pick-axes, sledge hammers, etc should be provided.
15. *Essential safety equipment should be used* including safety helmets, harnesses for lifting out injured personnel, gas detection

equipment, etc. Goggles and dust masks should be worn for stone cutting, ear protectors if using air hammers. First aid training and equipment should be part of the overall safety measures.

16. Dewatering: Safe and suitable dewatering equipment and techniques must be available and used. The Oxfam system of using a compressed air powered pump or electric dewatering/desludging pump fitted with a special set of devices are the safest techniques available. ***Under no circumstances should combustion engines, petrol or diesel powered pumps be lowered into wells to facilitate dewatering.*** This will lead to a lethal build-up of carbon monoxide which will cause death within seconds of anyone present in the well. If diesel or petrol engines are used at ground level, the exhaust gases from such engines must be diverted away from the well or excavation. Exhaust gases are heavier than air and will sink to the lowest levels possible.

17. Ventilation: Keep the well ventilated and test frequently for gases and foul air before entry each day and whenever a new stratum is encountered. The compressor supplying the dewatering pump can also be used to supply air when pumping is not required. If no blower or bellows are available, lower and raise a bundle of brushwood almost as big as the well opening to induce air changes.

18. Use of Explosives: the use of explosives for well blasting must only be carried out by fully competent and trained staff since the storage, handling, placing and detonation of explosives is a skilled operation. It is crucial, following the use of explosives, to purge the well of all toxic fumes remaining after detonations. Air safety tests should always be carried out. Air purging by standard air compressors is not suitable unless the atomised oil content of the compressed air is removed by suitable oil filters (as provided in kit WPC).

Locally made explosives using fertilisers, diesel oil, home made gunpowder or similar improvisation should not be used because of their haphazard and erratic performance.

19. Sanitation: facilities or arrangements should be provided to eliminate any risk of well diggers excreting or urinating in the well.

SECTION D – DETAILS OF KITS AND SUPPLIERS

Full list of kit contents

Survey Auger kit

Oxfam code **WAS**

(approximate gross weight 220kg & volume 0.58m³)

Item	Qty	Description
1	1	Pumphead jolly jumper
2	1	Riser pipe 1½" Ø x 500mm
3	15	Riser pipes 1½" Ø x 1000mm
4	1	Riser clamp 1½" Ø
5	1	Flexible hose 32/42mm x 600mm
6	4	Hose clips 5/4" Ø
7	2	Footvalves with strainers
8	1	Water level meter 10m
9	1	Steel head for casing 90/76mm Ø
10	1	Casing plain ABS with steel thread connector 90/76mm Ø x 500mm
11	12	Casing plain ABS with steel thread connector 90/76mm Ø x 1000mm
12	3	Casing slotted with steel thread connector 90/76mm Ø x 1000mm
13	1	Steel shoe for casing 90/76mm Ø
14	1	Tommy bar
15	2	Clamps for casing 90mm Ø
16	1	Retriever for casing 90mm Ø
17	2	Spanners/catchers for screw connection
18	1	Auger cleaner
19	2	Pipe wrenches 3" Ø
20	1	Flight auger 70mm Ø
21	1	Flight auger 100mm Ø
22	1	Spiral auger 40mm Ø
23	1	Stone auger 70mm Ø
24	1	Stone catcher 70mm Ø
25	1	Handle 26mm Ø x 1000mm
26	1	Handle 26mm Ø x 500mm
27	20	Extension rods 26mm Ø x 1000mm
28	5	Sets Spare conical thread connectors
29	1	Open clay auger 70mm Ø
30	1	Open clay auger 100mm Ø
31	1	Riverside auger 70mm Ø
32	1	Spare ring with teeth 70mm Ø
33	1	Riverside auger 100mm Ø
34	1	Spare ring with teeth 100mm Ø
35	1	Bailer 63mm Ø
36	1	Spare valve for bailer 63mm Ø
37	1	Oxfam's instruction manual for the Hand Dug Well equipment

Tool kit for well excavation

Oxfam code **WET**

(approximate gross weight 188kg & volume 0.92m³)

The Tool Kit for Well Excavation, (Oxfam code WET) provides the basic tools for digging a shallow well by hand. It is recommended that this operation is only carried out by experienced well diggers or supervised by experienced personnel.

Item	Qty	Description
1.	2	Chisel and Point Pick-axe with hard wood handle
2.	2	Filling Shovels 60cm long shaft
3.	2	Mixing Shovels 90cm long shaft
4.	2	Iron Pulley – malleable galvanised double sheave, block 300kg capacity
5.	2	Miner's Bar, one end chisel one end point, 3cm diameter and 1.5m long
6.	1	Sledge hammer 3kg weight
7.	1	Polypropylene Rope, 20mm dia x 70 metres long
8.	4	Plastic Helmet with chin strap
9.	4	Steel bucket, galvanised heavy duty
10.	1	10mm Sieve
11.	1	5mm Sieve
12.	1	3mm Sieve
13.	4	Trowels 20cm Blade
14.	2	Pliers side cutting 20cm long
15.	4	Hacksaw 30cm long 24 TPI with 10 spare blades
16.	1	1 Mason's bricklayers Level
17.	1	Cutters suitable for cutting sieves
18.	1	Plumb Bob
19.	2	5m Tape Measure
20.	1	30m Tape Measure
21.	10 pairs	Gloves heavy duty
22.	2	Hardwood Pick-axe handle
23.	4	Shovel handle
24.	1	Hammer handle
25.	1	Safety harness
26.	2 pairs	Wellington Boots size 7
27.	3 pairs	Wellington Boots size 8
28.	3 pairs	Wellington Boots size 9
29.	2 pairs	Wellington Boots size 10
30.	12 pairs	All Purpose Gloves
31.	1	Plastic fencing 50m roll

Well digging first aid kit**Oxfam code WFA**(approximate gross weight 6kg & volume 0.2m³)

Item	Qty	Description
1.	2	Fracture Immobiliser Pack – large and small
2.	6	Extra large field dressings
3.	2	Small field dressing
4.	1	Triangular bandage
5.	4	Large cotton conforming bandages – lightweight
6.	2	Packets cotton wool
7.	-	Hibidil sachets
8.	2	Eye dressings with pads
9.	6	Sachets Normasol
10.	2	Eye baths
11.	-	Surgikos large lightweight plastic gloves
12.	1	Resuciade
13.	-	Medipreps
14.	-	Safety pins
15.	-	Assorted haemostop dressings and plasters
16.	-	Elastoplast dressing strip
17.	2	Heat retaining blankets
18.	1	Pair scissors
19.	1	Pair large heavy-duty rubber gloves
20.	1	First Aid Manual
21.	1	Syringe kit
22.	1	Minor First Aid Kit (plastic box)
23.	1	Multi green coloured case, 40 x 30 x 15 cm, plus bracket
24.	1	Oxfam Code VFA, Vehicle First Aid Kit (Laerdal)

Hand dug steel well liner (5m of perforated and non-perforated sheets)**Oxfam code WL+P**(approximate gross weight 550kg & volume 0.8m³)

Corrugated steel sheet liner (non-perforated + perforated), 60cm depth, for hand dug wells comprising:

Item	Qty	Description
1.	12	Sheets, plain (non-perforated), galvanised corrugated MP68 bolted steel well lining, 67.7mm x 12.7mm corrugations. (3 sheets form one ring of 1.3m internal diameter)
2.	12	Sheets, (perforated with holes), galvanised corrugated MP68 bolted steel well lining, 67.7mm x 12.7mm corrugations. (3 sheets form one ring of 1.3m internal diameter)

3.	1	Tub with 250 standard nuts and bolts for above, M12 x 32mm
4.	1	MP68 Tool Kit comprising: 2-22mm A/F Box Spanner 1-22mm Open Ended Spanner/Podger
5.	1	Oxfam Instruction Manual for Hand Dug Well equipment

Well mould for non-perforated and perforated concrete rings**Oxfam code WM+P**(approximate gross weight 452kg & volume 1.14m³)

1.5M Ø steel well ring mould to standard specification – perforated, hand-dug well ring mould for concrete pre-cast rings. 1.5m external 1.3m internal diameter, 0.6m deep.

Item	Qty	Description
1.	4	Base unit
2.	4	Outer mould panel with 48 No 14mm dia holes for perforations
3.	4	Inner mould panel with 48 No 14mm dia holes for perforations
4.	4	Inner mould infill channel
5.	1	Lifting beam
6.	2	Dowel bar fixing plate
7.	8	Clamping down plate
8.	4	Dowel hole cone
9.	8	Dowel hole cone unit (for timer or concrete bases – 2 sets)
10.	15	Standard 12mm dia bolt x 30mm length
11.	10	Standard 12mm dia nuts (2 spare)
12.	10	Fast thread “L” bolt with nut (2 spare)
13.	16	Fast thread 12mm dia bolt x 105mm length plus nut (2 spare)
14.	16	Fast thread 12mm dia bolt x 50mm length plus nut (2 spare)
15.	48	10mm dia steel rods for forming perforations
16.	500	14mm dia plastic bungs for use in plugging perforation holes
17.	2	Spanners (open ended)
18.	1	Oxfam instruction manual for Hand Dug Well equipment
Expendable items		
19.	40	Dowel/lifting bars (for 10 castings)

Whilst this ring mould is perforated, the use of plastic plus supplied (by placing these in the mould perforation holes), will enable the production of concrete rings without perforations in. The plugs can be used many times but will eventually get worn out, so five complete sets have been provided.

Dewatering kit (mobile air pump and compressor)

Oxfam code WPC

(approximate gross weight 370kg & volume 1.52m³)

Item	Qty	Description
1.	1	1½" Double Diaphragm Air Pump with 1½" inlet/outlet elbows
2.	1	Mobile Diesel Engine Compressor comprising: Yanmar 10HP, single cylinder, recoil start engine, 2 cylinder, 2 stage air-cooled reciprocating compressor c/w Filter/Regulator Set. Air receiver 65 litre with Safety Valve, Pressure Gauge and outlet valve Mounted on 2 wheel site trolley
3.	1	30m ½" Contractors air hose c/w Q A Couplings
4.	1	15m ½" Contractors air hose c/w Q A Couplings
5.	1	5m 1½" rigid Suction Hose complete with fittings N R valve with strainer and clips
6.	1	30m ½" Discharge air hose c/w Q A Couplings
7.	1	15m ½" Discharge air hose c/w Q A Couplings
8.	1 set	Tool kit comprising: 6 Piece combination wrench set, AF set comprising 3/8" – ¾" and metric spanners 12-17mm, 3", 4", 6" cross point screwdrivers, ½", 3", 4", 6" plain slotted screwdrivers, 1½" Chubby slotted screwdriver
9.	1 set	Engine spares for 2000 hours running comprising
	2	Fuel Filter
	2	Fuel Oil Filter (Filler Cap)
	2	Fuel Filter (Strainer Lub Oil)
	2	Air Filter (Element)
	1	Fuel Injector Nozzle
	1	Valve Suction
	1	Valve Exhaust
	1	Seal, Valve Stem
	1	Rocker cover gasket
10.	1 set	Mobile Air Pump Spares for 2000 hours:
	1	Dry side kit
	1	Wet side kit
11.	1	Set compressor spares for 2000 hours running comprising:
	1	Valve gasket set
	2	Air intake filters
	2	Vee belts
12.	2	5 litre cans of compressor oil
13.	1	5 litre can of engine oil
14.	1 set	Operating/maintenance instructions and Yanmar engine manual
15.	1	Oxfam instruction Manual for Hand Dug Well equipment

Electrical dewatering/desludging pump kit with petrol generator

Oxfam code WSDP

(approximate gross weight 200 kg & volume 0.8 m³)

This is a lightweight electrical de-watering pump kit for handling heavily contaminated water with solids up to 50mm in diameter. Maximum head 20m

Item	Qty	Description
1.	1	Heron SH - 2QTP pump set comprising 2" (50mm) immersible/submersible pump type SH. Direct driven by 1.5 kw 400 volt 3 phase 50 hz IP68 electric motor. Free standing on its own feet. Complete with male hose tail outlet and 25 metres of lead with 16 amp plug fed from the generator set.
2.	1	A removable anti-dive plate will be attached to the base of the pump to prevent "boring" in muddy conditions.
3.	1	6000 watt 400 volt 3 phase 50 cycle brushless generator fitted with hourscounter, 1 no. 16 amp output socket protected by a power circuit breaker (ground fault detector) earth leakage trip to prevent fatal electric shocks should the power lead or pump develop a fault or be damaged. Flanged coupled to a Briggs & Stratton OHV petrol engine type 245432 governed to run at 3000 rpm complete with recoil starter, 3 hour fuel tank, low oil protection, exhaust system, air and oil filters. The whole unit mounted on anti vibration mounts inside a robust tubular roll frame. Supplied with: 40m Pump supporting wire cable + 6 cleats 1 Pulley for the supporting cable 20m Electrical extension cable with socket connectors 25m 2" layflat PVC delivery hose & 2" hose clip, Tool kit comprising:- spark plug spanner, screwdriver and oil drain spanner, 5 x 1.4 litre containers of engine oil (allowing 4 complete refills plus spillage) 1 x 5 litre empty petrol can 1 sliding collar to fit over the layflat where it exits the well. 1 2" M Hose coupling
4.	1	Operator's manual
5.	1	2-wheel site trolley for generator set
6.	1 set	Spares for 1000 hrs operation comprising: 2 Spark plugs 2 Air filter elements 1 16 amp plug 1 2" hose clip
7.	25M	Cable protection hose
8.	1	Oxfam manual for hand-dug well equipment

Well Tripod kit**Oxfam code WT6**(approximate gross weight 485kg & volume 1.34m³)

Item	Qty	Description
1.	1	Steel tripod, length 6 metres, in parts of 2.40, 1.50 and 2.10 metres
2.	1	Spare head for tripod
3.	1	Handwinch with gear 1:4, with 2 handles
4.	1	50 metres galvanised steel wire 10mm Ø, (for winch)
5.	1	Pully Block with swivel hook, 8" Ø – 2 tons capacity
6.	1	Pully Block with flapdoor, 5" Ø
7.	1	Double Pulley Block, 5" Ø
8.	4	Steel footplates 330 x 330 mm
9.	3	D-shackles 26mm
10.	6	Thimbles for 10mm wire
11.	12	Clamps for 10mm wire
12.	1	Swivel hook, capacity 3 tons, with safety latch
13.	1	Swivel hook, capacity 3 tons, with ball bearing
		ORANGE COLOUR PULLEYS – EXTRA FOR 20mm Ø ROPE
14.	1	Pulley Block Ø 6", with glacier bush, capacity 2 tons
15.	1	Pulley Block with flapdoor 6" Ø with glacier bush, capacity 2 tons
16.	1	Double Pulley Block, 6" Ø with glacier bush, capacity 3 tons

Compressor air tools/kit**Oxfam code WPC****Not Oxfam Stock Item***(For use with WPC compressor)*

Item	Qty	Description
1.	1	35mm Pneumatic Concrete Vibrator c/w 2m flexible
2.	1	45mm Pneumatic Concrete Vibrator c/w 2m flexible
3.	1	Pneumatic Pick Hammer with Chisel and Point
4.	1	Pneumatic Medium duty 3/8" Pistol Grip Drill
5.	1	Pneumatic Heavy Duty 3/8" Pistol Grip Drill

Compressor service and overhaul kit**Oxfam code WPCS****(Not Oxfam Stock Item)***This kit is specifically designed for the Oxfam code WPC Dewatering Kit*

Item	Qty	Description
1.	1 set	Compressor service kit comprising:
	2	Cylinder Head Gaskets LP Cylinder
	2	Cylinder Head Gaskets HP Cylinder
	2	Valve Gasket LP Cylinder
	2	Valve Gasket HP Cylinder
2.	1 set	Overhaul kit comprising:
	2	Gasket (housing)
	2	Valve Plates Suct HP
	2	Valve Plates Del. HP
	2	Valve Plates Suct. LP
	2	Valve Plates Del. LP
	2	Cylinder Head Gaskets
	2	Cylinder Head Gaskets Dis. Sect

<p>List of suppliers used by Oxfam (based in Europe)</p>

Hand Dug Well Kits WAS, WT6 supplied by:
Van Reekum Materials bv Oude,
Apeldoornseweg 36, PO Box 98, NL 7300 AB
Apeldoorn, NETHERLANDS
Tel 00 31 555 335466; Fax 00 31 555 335488

WFA supplied by:
Various upon application to Oxfam House

WPC, WPCS and WPCT supplied by:
A W Phillips & Son (Upton Park) Ltd, 47-51
Plashet Grove, London E6 1AD
Tel 0181 472 6656/0171 473 1023;
Fax: 0171 511 0194

OR supplied by:
Van Walt Agricultural Services, Prestwick Lane,
Grayswood, Haslemere, Surrey GU27 2DU
Tel 01428 661660; Fax 01428 656808

WL+P supplied by
Asset International Ltd
Stephenson House
Newport
Gwent NP9 0XH
Tel 01633 273 081
Fax 01633 281 301

WET supplied by:
The Kennedy Group Ltd
Wigston Works
Victoria Street, Wigston,
Leicester LE8 1AJ
Tel 0116 288 8777; Fax 0116 281 3293

WM+P supplied by:
WIG Engineering Ltd, Mill Road
Kirtlington, Oxon OX5 3JE
Tel 01869 350200; Fax 01869 350960

Final Reminders and Recommendations

- Check the likelihood of finding ground water at reasonable depth, using all possible local information, before starting well digging.
- Make every effort to use locally experienced well diggers and supervisors.
- Ensure thorough safety training is given to all workers and supervisors and alert local residents of the dangers.
- Observe safety procedures at all times, especially noting the dangers from engine fumes and falling objects.
- Do not run engines at high speeds for long periods.
- Ensure regular, competent maintenance, with correct tools and spares: use only clean fuel.
- Check engine oil level daily.
- Carry out maintenance at least at maker's recommended intervals.
- Ensure local residents are aware of the presence and dangers of wells and have been trained in maintenance, especially maintenance of hand pumps if fitted.
- Ensure that all water supply programmes include health/hygiene promotion and education.

References

1. Hand dug wells and their construction. S B Watt and W E Wood. IT Publications 1995
2. Groundwater Dams for Small-scale Water Supply. Ake Nilsson. IT Publications 1988
3. Engineering in emergencies, Davis and Lambert RedR/IT 1995
4. 'Safety in Wells and Boreholes'. Institution of Civil Engineers 1972.
5. British Standard BS 5573:1978 'Safety precautions in the construction of large diameter boreholes for piling and other purposes'

Acknowledgements

The original development of the Water equipment packages was made possible with the generosity and professional skill of the University of Surrey and the Public Health Engineering section of Imperial College, London. Since then, active development and evolution of the water kits has continued, managed by the Oxfam GB Public Health Engineering Team, based on feedback from engineers working on response programmes and with continued input from suppliers, and others.

Oxfam has received much support in the development of the Well Digging equipment, from the Gatsby and Bucklesbury Trusts. We are grateful to E G Pike for his work in the production of the survey and dewatering sections. The latest edition of this manual is substantially based upon the previous edition, which was written by Alan Reed.

Richard Luff
APRIL 2000

Oxfam is a partnership of people committed to relieving poverty, distress and suffering in any part of the world. We believe in the essential dignity of people and in their capacity to overcome the problems they face, whether they stem from natural, social, political or economic conditions.

This equipment is part of several packages devised by the Oxfam Public Health Engineering Team to help provide reliable water, sanitation and shelter facilities in emergency situations.

Oxfam (GB)
274 Banbury Road, Oxford OX2 7DZ, UK
Tel: (01865) 311311 Fax: (01865) 312600

Final Reminders and Recommendations

- Check the likelihood of finding ground water at reasonable depth, using all possible local information, before starting well digging.
- Make every effort to use locally experienced well diggers and supervisors.
- Ensure thorough safety training is given to all workers and supervisors and alert local residents of the dangers.
- Observe safety procedures at all times, especially noting the dangers from engine fumes and falling objects.
- Do not run engines at high speeds for long periods.
- Ensure regular, competent maintenance, with correct tools and spares: use only clean fuel.
- Check engine oil level daily.
- Carry out maintenance at least at maker's recommended intervals.
- Ensure local residents are aware of the presence and dangers of wells and have been trained in maintenance, especially maintenance of hand pumps if fitted.
- Ensure that all water supply programmes include health/hygiene promotion and education.

References

1. Hand dug wells and their construction. S B Watt and W E Wood. IT Publications 1995
2. Groundwater Dams for Small-scale Water Supply. Ake Nilsson. IT Publications 1988
3. Engineering in emergencies, Davis and Lambert RedR/IT 1995
4. 'Safety in Wells and Boreholes'. Institution of Civil Engineers 1972.
5. British Standard BS 5573:1978 'Safety precautions in the construction of large diameter boreholes for piling and other purposes'

Acknowledgements

The original development of the Water equipment packages was made possible with the generosity and professional skill of the University of Surrey and the Public Health Engineering section of Imperial College, London. Since then, active development and evolution of the water kits has continued, managed by the Oxfam GB Public Health Engineering Team, based on feedback from engineers working on response programmes and with continued input from suppliers, and others.

Oxfam has received much support in the development of the Well Digging equipment, from the Gatsby and Bucklesbury Trusts. We are grateful to E G Pike for his work in the production of the survey and dewatering sections. The latest edition of this manual is substantially based upon the previous edition, which was written by Alan Reed.

Richard Luff

APRIL 2000

Oxfam is a partnership of people committed to relieving poverty, distress and suffering in any part of the world. We believe in the essential dignity of people and in their capacity to overcome the problems they face, whether they stem from natural, social, political or economic conditions.

This equipment is part of several packages devised by the Oxfam Public Health Engineering Team to help provide reliable water, sanitation and shelter facilities in emergency situations.

Oxfam (GB)
274 Banbury Road, Oxford OX2 7DZ, UK
Tel: (01865) 311311 Fax: (01865) 312600